

CORPUS DER HIEROGLYPHISCHEN INSCHRIFTEN
AUS DEM GRAB DES TUTANCHAMUN

CORPUS DER
HIEROGLYPHISCHEN INSCRIFTEN
AUS DEM GRAB DES
TUTANCHAMUN

mit

Konkordanz der Nummernsysteme
des 'Journal d'Entrée' des Ägyptischen Museums Kairo,
der *Handlist to Howard Carter's Catalogue of
Objects in Tutankhamūn's Tomb*
und der Ausstellungs-Nummer
des Ägyptischen Museums Kairo

HORST BEINLICH

MOHAMED SALEH

GRIFFITH INSTITUTE
ASHMOLEAN MUSEUM, OXFORD

1989

© Griffith Institute, Oxford 1989

ISBN 0-900416-53-X
All rights reserved

British Library Cataloguing in Publication Data

Beinlich, Horst

Corpus der hieroglyphischen Inschriften aus dem Grab des Tutanchamun, mit Konkordanz der Nummernsysteme des 'Journal d'Entrée' des Ägyptischen Museums Kairo, der 'Handlist to Howard Carter's catalogue of objects in Tut'ankhamun's tomb' und der Ausstellungs-Nummer des Ägyptischen Museums Kairo.

1. Egypt. Valley of the Kings. Ancient Egyptian royal tombs: tomb of Tut'ankhamun, Pharaoh of Egypt. Inscriptions. Texts.

I. Title II. Saleh, Mohamed

493'.1

ISBN 0-900416-53-X

INHALTSVERZEICHNIS

Vorwort	vii
Einleitung	ix
Introduction	xi
Abkürzungsliste zum Textnachweis	xiii

TEIL I

Corpus der hieroglyphischen Inschriften aus dem Grab des Tutanchamun

Zeichenerklärung—Explanation of signs	xvi
Textabschriften	1
Grab	1
Carter-Nr. 1–620 (122)	3
Stücke ohne Carter-Nr.	224
Siegeltypen ‘A’ bis ‘S’	226
Siegeltypen ‘AA’ bis ‘OO’	227
Indices	229
Index der Eigennamen	229
Index der Götternamen	229
Abschnitte aus größeren Textzusammenhängen	231
Index der Stichworte	231

TEIL II

Konkordanz der Nummernsysteme

des ‘Journal d’Entrée’ des Ägyptischen Museums Kairo,
der *Handlist to Howard Carter’s Catalogue of Objects*
in *Tutankhamun’s Tomb* und

der Ausstellungs-Nummer des Ägyptischen Museums Kairo 235

Zum Geleit—Introductory note	236
Konkordanz nach JE-Nummern	238
Konkordanz nach Carter-Nummern	250
Konkordanz nach Ausstellungsnummern	262
Index zum Journal d’Entrée	274
nach Objekten alphabetisch geordnet	274
nach JE-Nummern geordnet	276
Index to the Journal d’Entrée	278
Objects, listed alphabetically	278
Listed by JE numbers	281

VORWORT

Das vorliegende Buch entstand aus dem Bestreben, die Texte, die im Grab des Tutanchamun gefunden wurden, allgemein zugänglich zu machen und damit der wissenschaftlichen Bearbeitung des Grabfundes eine breitere Grundlage zu geben. Das so entstandene Corpus der hieroglyphischen Inschriften aus dem Grab des Tutanchamun versteht sich selbst als ein Provisorium, das solange Bestand haben soll, bis es durch die endgültige Publikation des Grabinventars überholt ist. Der Plan zu dem Unternehmen wurde 1983 gefaßt, und es konnte zu seiner Durchführung die Unterstützung der Egyptian Antiquities Organization und des Griffith Institute, Ashmolean Museum, gewonnen werden. So war es möglich, die Texte sowohl an den Originalen aus dem Tutanchamun-Grab in Kairo als auch mit Hilfe der Photos und Abschriften des Carter-Archives in Oxford aufzunehmen. Beiden Institutionen sei an dieser Stelle für ihre Unterstützung des Projektes gedankt. Dank gebührt auch der Deutschen Forschungsgemeinschaft, die die finanziellen Mittel für die notwendigen Reisen nach Oxford und Kairo zur Verfügung stellte.

All jenen, die zur Verwirklichung des Corpus' beigetragen haben, sei an dieser Stelle herzlich dafür gedankt, besonders hervorzuheben sind dabei Herr Prof. John R. Harris, Herr Dr. Jaromir Malek, und Herr Prof. John Baines, die mit gutem Rat und tatkräftiger Hilfe die Arbeit am Carter-Archiv des Griffith Institute sehr erleichtert haben. Dank gesagt sei auch Herrn Dr. C. Nicholas Reeves, der freundlicherweise die Vorlagen für die Abbildungen der Siegel A bis S zur Verfügung stellte. Herrn Richard Jasnow verdanken wir die Übersetzung der Einleitung ins Englische.

Der hieroglyphische Teil des vorliegenden Buches wurde mit dem von Herrn Norbert Stief vom Regionalen Hochschulrechenzentrum der Universität Bonn entwickelten Programmsystem zur Ausgabe von Hieroglyphen auf Plotter vorbereitet. Es sollte dabei gleichzeitig getestet werden, wie sich das System für die Publikation größerer Textmengen eignet. Dank dieses Programmes wurden für die Anfertigung der hieroglyphischen Druckvorlage keine drei Monate gebraucht und damit die Dauer des Gesamtunternehmens erheblich verringert. Herrn Stief soll an dieser Stelle ganz besonders herzlich gedankt werden, daß er nicht nur das System zur Verfügung stellte, sondern auch immer wieder bereit war, bei auftretenden Problemen zu Beginn und während der Arbeit zu helfen und sogar Änderungen und Ergänzungen in sein System einzubauen.

Die Eingabe der Hieroglyphen und ihre Verarbeitung konnte am Rechenzentrum der Universität Würzburg durchgeführt werden. Dem Leiter des Rechenzentrums Herrn Wolfgang Schliffer und seinen Mitarbeitern sei für ihre Gastfreundschaft und stete Hilfe gedankt. Besonderer Dank gebührt hier Herrn Peter Ruff, der als Ansprechpartner für den EDV-Laien nie die Geduld verlor und gleichbleibend hilfsbereit war.

Schließlich sei noch dem Griffith Institute Committee für seine Bereitschaft gedankt, das Corpus der hieroglyphischen Inschriften aus dem Grab des Tutanchamun zu publizieren.

HORST BEINLICH

MOHAMED SALEH

EINLEITUNG

Obwohl nunmehr 65 Jahre seit der Entdeckung des Grabes von Tutanchamun durch Howard Carter vergangen sind, ist die Zahl der Gegenstände aus diesem Grab, die als publiziert gelten können, gemessen an der ungeheueren Fülle der Fundgegenstände, verhältnismäßig gering. Dies gilt vor allem für das inschriftliche Material; es ist dabei erstaunlich, daß selbst die Texte der bekanntesten Stücke bisher weder durch Photos, noch durch Abschriften dokumentiert wurden. Die vorliegende Arbeit soll hier Abhilfe schaffen und eine Grundlage bei der Erschließung des Textmaterials bilden.

Auf den nachfolgenden Seiten werden die Abschriften aller Texte aus dem Grab des Tutanchamun gegeben, soweit sie in Hieroglyphen geschrieben wurden. Eine Ausnahme bilden die vier großen Grabschreine, die Alexandre Piankoff schon 1952 veröffentlicht hat. Diese Texte wurden nicht noch einmal aufgenommen. An den entsprechenden Stellen wird auf die Publikation von Piankoff verwiesen. Im Index der 'Abschnitte aus größeren Textzusammenhängen' (d.i. Totenbuch usw.) werden die Texte auf den Schreinen mitberücksichtigt. Bei den hieratischen Texten aus dem Grab des Tutanchamun wird auf die Publikation von Jaroslav Černý (TutTS 2) verwiesen. Einige wenige hieratische Inschriften, die von Černý nicht aufgenommen wurden, sind bei den entsprechenden Objekten nachgetragen. Nicht berücksichtigt werden Umsetzungen des Thronnamens in Schmuckelemente, etwa bei Pektoralen oder bei dem sgn. Doppelgefäß (Carter-Nr. 240 bis). Ebenso werden auch Hieroglyphen, die rein ornamentalen Charakter haben (z.B. Schriftbänder aus Anch- und Was-Zeichen) nicht in dem Corpus wiedergegeben. Die Textabschriften wurden zunächst nach allgemein zugänglichen Photographien vorbereitet und dann am Griffith Institute in Oxford anhand der dort aufbewahrten Photos von Harry Burton überprüft und ergänzt. Die so gewonnene Textgrundlage wurde dann an den Originalen im Ägyptischen Museum Kairo, dem Museum für altägyptische Kunst in Luxor und im Grab des Tutanchamun wiederum überprüft und ergänzt. Nur in einigen wenigen Fällen war eine Autopsie—sei es nach Photos, sei es nach den Originalen—nicht möglich. Solche fehlende Autopsie ist mit einem Sternchen bei der jeweiligen Bezeichnung des Fundgegenstandes gekennzeichnet. Stücke in außerägyptischen Museen, die vielleicht oder wahrscheinlich aus dem Grab des Tutanchamun stammen, werden in dem Corpus nicht berücksichtigt. Auf eine Übersetzung der Texte wurde verzichtet, da sie den Rahmen der Publikation gesprengt hätte.

Alle Textabschriften werden grundsätzlich waagrecht und von links nach rechts wiedergegeben, da die Wiedergabe eines Textes in originaler Laufrichtung naturgemäß ein Vielfaches des Platzes beansprucht hätte. Die originale Laufrichtung einer Zeile ist jeweils am Anfang der Zeile angegeben und gilt bis zur Angabe einer anderen Laufrichtung. Der Klarheit wegen sei gesagt, daß es sich bei den dafür verwendeten Pfeilen um die Leserichtung handelt, nicht etwa um die Blickrichtung der Hieroglyphen. Die Angabe der Laufrichtung einer Zeile soll dazu beitragen, daß man sich die Textanordnung einer Inschrift auf dem Textträger besser vorstellen kann. Dem gleichen Zweck dienen bei einigen Objekten Skizzen, bei denen die Zeilennummerierung eingetragen ist, und die Angabe von 'Textnachweisen'. Diese 'Textnachweise' sind keinesfalls mit einer Bibliographie zum jeweiligen Stück zu verwechseln. Sie geben nur eine beschränkte Anzahl von Abbildungen des Objektes in allgemein zugänglichen Publikationen wieder, auf

denen die originale Textanordnung deutlich wird. Abbildungen in Carters Tutanchamun-Publikation sind in den meisten Fällen nicht aufgenommen. Sie lassen sich unschwer über die *Handlist* (TutTS 1) finden. In einigen Fällen war für den 'Textnachweis' nur die deutsche Ausgabe einer Publikation zugänglich. Das Wiederfinden der zitierten Abbildung in einer anderssprachigen Ausgabe dürfte jedoch keine Schwierigkeiten bereiten.

Die Begriffe 'links' und 'rechts' werden in dem 'Corpus' auf den Betrachter bezogen, der auf die Vorderseite eines Objektes schaut, dagegen wird bei anthropomorphen Gegenständen wie etwa den Särgen von 'linker' bzw. 'rechter Körperseite' gesprochen. 'Links' und 'rechts' ist in diesem Falle vom Betrachter unabhängig. Die Angabe der Leserichtung bei Textzeilen ist aber in jedem Falle auf den Lesenden bezogen.

Die Textwiedergabe erfolgte mit Hilfe von computer-gesteuerten Zeichnungen, d.h. bei den Hieroglyphen handelt es sich nicht um Faksimiles, sondern um in ihrer Form festliegende Zeichentypen. Die Hieroglyphen sind in ihrer richtigen Reihenfolge wiedergegeben, ihre Anordnung innerhalb von Zeichengruppen entspricht aber nicht immer dem Original. Zeichen und Zeichengruppen (Anch, Djet, usw.), die aus graphischen Gründen nur einmal zwischen sonst voneinander unabhängigen Textzeilen stehen, aber bei jeder dieser Zeilen mitgelesen werden müssen, sind entsprechend häufig als Hieroglyphe wiedergegeben, ohne daß dies besonders angemerkt wird.

Für die Reihenfolge der Textwiedergaben standen grundsätzlich zwei unterschiedliche Numerierungssysteme zur Verfügung: das von Howard Carter und das des Ägyptischen Museums Kairo (JE). Wegen der Compatibilität mit der *Handlist* (TutTS 1) fiel die Entscheidung zugunsten der Carter-Nummern aus. Es zeigte sich aber, daß eine Konkordanz der verschiedenen Nummernsysteme unbedingt notwendig ist. Sie bildet den zweiten Teil des vorliegenden Buches und versucht darüberhinaus, durch Indices in deutsch und englisch (wegen der Originalangaben im JE) weitere Hilfestellungen bei Arbeiten mit dem Tutanchamun-Material zu geben. In zwei Fällen mußte das Numerierungssystem von H. Carter ergänzt bzw. erweitert werden. Bei der Arbeit im Ägyptischen Museum Kairo wurden noch 47 Textfragmente aufgenommen, die zu der Carter-Nummer 122 0000 gehören, aber nicht in der *Handlist* erwähnt sind. Sie wurden als Carter-Nr. 122 0000 (1) bis 122 0000 (47) in das System eingebaut. Im anderen Fall handelt es sich um zwei Reihen von Siegeltypen, die Carter jeweils mit 'A' beginnt, und die bis 'S' bzw. bis 'O' reichen. Hier wurde bei der zweiten Reihe der Siegeltypen—hauptsächlich Weinsiegel—der Typen-Buchstabe verdoppelt, so daß die Reihe nun von 'AA' bis 'OO' reicht und eine Verwechslung ausgeschlossen ist.

Schwierigkeiten bei der Identifizierung von Objekten aus dem Grab des Tutanchamun mit den Stücken im Ägyptischen Museum Kairo gab es vor allem bei den Uschebtis. Hier mußten einige der Angaben, die das JE zu den Carter-Nummern macht, in Frage gestellt werden. Um eine sichere Arbeitsgrundlage zu gewinnen, wurde bei den Textabschriften die JE-Nummer am Objekt selbst überprüft. Diese Angabe muß deshalb in Bezug auf eine Textabschrift als sicher gelten, während für die beigefügte Carter-Nummer nicht in jedem Falle gebürgt werden kann. Deshalb und auch weil in vielen Fällen eine Carter-Nummer keinen bestimmten Uschebti, sondern eine Gruppe bezeichnet, empfiehlt es sich, beim Zitieren beide Nummern anzugeben.

Im Anhang an die Textwiedergaben finden sich noch einige Indices. Die Zahlen in diesen Indices beziehen sich auf die Carter-Nummer.

INTRODUCTION

Although more than 65 years have passed since Howard Carter's discovery of the tomb of Tutankhamun, relatively few of the vast number of objects from this tomb have been adequately published. This is particularly true of the inscribed material. It is nonetheless astonishing that even the texts of the most famous pieces have never been made accessible in photographs or copies. The present work is intended to improve this situation and to provide a basis for analysing the textual material.

On the following pages are copies of virtually all the hieroglyphic texts from the tomb of Tutankhamun. The sole exceptions are the inscriptions on the four great shrines, which Alexandre Piankoff published in 1952. We have not recorded these texts once more, but have provided references in the appropriate places to Piankoff's publication. In the index of citations from the Book of the Dead, Coffin Texts, etc., the texts on the shrines are taken into account. For the hieratic inscriptions from the tomb of Tutankhamun we refer the reader to the publication of Jaroslav Černý (TutTS 2). The few hieratic texts not recorded by Černý are included in the documentation of the relevant objects.

We have not taken into consideration cases where the Throne name of Tutankhamun is employed as a decorative element, on pectorals, for example, or on the so-called 'Double vase' (Carter No. 240 bis). Similarly, purely decorative hieroglyphs (e.g. bands of Ankh and Was signs) are not reproduced in the Corpus.

Preliminary text copies were first prepared from generally available photographs. Next, these were then checked and supplemented at the Griffith Institute in Oxford, using the photographs of Harry Burton which are deposited there. We then collated these copies with the originals in the Egyptian Museum in Cairo, the Luxor Museum of Ancient Egyptian Art, and in the tomb of Tutankhamun. Only rarely was it not possible to inspect personally either a photograph or the original of a piece. These cases are marked by an asterisk * at the beginning of an entry. Objects in museums outside Egypt which may, with varying degrees of probability, derive from the tomb of Tutankhamun have not been included in this corpus. We have also not translated the texts, since this would have gone beyond the scope of the publication.

As a rule, all text copies are reproduced horizontally and proceeding from left to right. This mode of presentation proved necessary, because the reproduction of a text in the original direction of writing would have required an inordinate amount of space. The original direction of writing is indicated at the beginning of each inscription and wherever the direction changes. It should be stated for the sake of clarity that the arrows specify the direction of reading, and not the direction in which the hieroglyphs face. The indication of the direction of writing in a line is intended to help the reader to understand better the arrangement of the text on an inscribed piece; sketches of objects, to which line numbers are added, are intended to serve the same purpose. Similarly, the *Textnachweise* for published objects refer the reader to selected publications containing illustrations which show clearly the original arrangement of the texts; they are in no way to be confused with bibliographies of those pieces. Illustrations in Carter's *The Tomb of Tut-ankh-Amen* publication have not, for the most part, been cited. They can easily be found through the *Handlist* (TutTS 1). In several cases only the German edition of a publication was available for the *Textnachweis*. In such cases it should not be difficult to trace the relevant illustration in an edition in another language.

In the Corpus, the terms 'left' and 'right' are employed from the perspective of the

observer looking at the front of an object. However, for anthropomorphic objects such as sarcophagi, the phrases 'linke Körperseite' (left side of the body) or 'rechte Körperseite' (right side of the body) are sometimes used. In these cases, 'left' and 'right' are independent of an observer. The direction of reading in lines of text is always indicated with reference to the reader.

The production of the text was carried out with the aid of a computer program. This means, of course, that the hieroglyphs are not facsimiles, but have a conventional form. The hieroglyphs are reproduced in their original sequence, but the arrangement within a sign group does not always correspond to that of the original. Signs and sign groups (*ankh*, *djet*, etc.) written once between distinct lines of text, but intended to be read with each of these lines, are often accordingly reproduced more than once without comment.

Two fundamentally different numbering systems were available for the sequence of text copies: the system of Howard Carter and that of the Egyptian Museum in Cairo (JE, *Journal d'Entrée*). For the sake of compatibility with the *Handlist* (TutTS 1), we decided to employ the Carter Numbers. It soon became clear, however, that a concordance of the two numbering systems was absolutely necessary. This concordance forms the second part of the present book. Supplemented by indices in German and English (derived from the original entries in the *Journal d'Entrée*), this should provide additional help to those who work on the Tutankhamun material. In two instances the numbering system of Howard Carter had to be supplemented or enlarged. In the course of work in the Egyptian Museum in Cairo, 47 fragments of text were recorded which are not mentioned in the *Handlist*, although they have the Carter number 122 0000. These were incorporated into the system as Carter No. 122 0000 (1)–122 0000 (47). The other case relates to two series of seal types. Carter employed 'A' for both series, the one running up to 'S', the other to 'O'. Here the letter designation of the second series of seal types, mainly wine-jar seals, was doubled, so that the sequence now runs from 'AA' to 'OO' and confusion is thereby avoided.

The shawabtis in particular presented difficulties during the process of identifying objects from the tomb of Tutankhamun with the pieces in the Egyptian Museum in Cairo. Several of the statements in the JE about Carter Numbers had to be questioned. In order to establish a more solid working basis, we verified the JE number on the object itself when copying the text. This information may therefore be considered certain with reference to a text copy, but the correctness of the appended Carter Number cannot be guaranteed in every case. For that reason, and because a Carter Number often does not denote a single shawabti but an entire group, it is recommended that both numbers be given when citing a shawabti.

After the text copies follow several indices. The numbers used in these indices are Carter Numbers.

ABKÜRZUNGSLISTE ZUM TEXTNACHWEIS

- Aldred C. Aldred, *Jewels of the Pharaohs* (London 1971; gleiche Abbildungszählung: C. Aldred, *Die Juwelen der Pharaonen*, München 1972)
- ASAE 40 (1940) R. Engelbach, 'Material for a revision of the history of the heresy period of the XVIIIth dynasty', *ASAE* 40 (1940) 133–65
- Brüssel *Onder de Zon van Amarna. Echnaton en Nefertiti (Le règne du soleil. Echnaton et Néfertiti*, Bruxelles 1975; Ausstellungskatalog)
- Carter H. Carter–A. Mace, *The Tomb of Tut-ankh-Amen* (London 1923–33; deutsch: H. Carter–A. Mace, *Tut-ench-Amun*, Leipzig 1924–34)
- David R. David, *Agypten* (Hamburg 1981)
- Davies N. de Garis Davies–A. H. Gardiner, *Tutankhamun's Painted Box* (Oxford 1962)
- Desroches-Noblecourt Chr. Desroches-Noblecourt, *Vie et mort d'un pharaon. Toutankhamon* (Paris 1963)
- Deutschland (1976) *Nofretete. Echnaton* (München 1976); *Echnaton. Nofretete. Tutanchamun* (Hildesheim 1976; Ausstellungskatalog)
- Deutschland 80/81 *Tutanchamun* (Ausstellungskataloge für Berlin, Köln, München, Hannover, Hamburg; Mainz 1980)
- Edwards I. E. S. Edwards, *Tutanchamun* (Bergisch Gladbach 1980)
- Fox, *Schatz* P. Fox, *Der Schatz des Tut-ench-Amun* (Wiesbaden 1960)
- Fox, *Treasure* P. Fox, *Tutankhamun's Treasure* (London 1951)
- Japan 65/66 Tutankhamen Exhibition in Japan 1965. (Ausstellungskatalog)
- Lange, *Pyramiden* K. Lange, *Pyramiden, Sphinxen, Pharaonen* (München 1952)
- Lange–Hirmer K. Lange–M. Hirmer, *Agypten* (München 1967)
- Le monde égyptien II* *L'empire des conquérants* (J. Leclant, Hrsg., *Le monde égyptien II*), Paris 1979
- Le Musée du Caire* E. Drioton, *Le Musée du Caire*, Encyclopédie Photographique de l'Art (Paris 1949)
- London *Treasures of Tutankhamun* (London 1972, Ausstellungskatalog)
- Paris *Toutankhamon et son temps* (Paris 1967, Ausstellungskatalog)
- Piankoff A. Piankoff, *Les chapelles de Tout-ankh-Amon MIFAO 72* (Le Caire 1952)
- Riesterer P. Riesterer, *Das Agyptische Museum Kairo II, Grabschatz des Tut-ench-Amun* (Bern 1965)
- Romer J. Romer, *Valley of the Kings* (London 1981)
- Saleh, *Hauptwerke* M. Saleh–H. Sourouzian, *Die Hauptwerke im Agyptischen Museum Kairo* (Mainz 1986)
- Seton-Williams M. V. Seton-Williams, *Tutanchamun* (Frankfurt/M. 1980)
- Small Golden Shrine* M. Eaton-Krauss–E. Graefe, *The Small Golden Shrine from the Tomb of Tutankhamun* (Oxford 1985)

Spanien	<i>Arte faraonico</i> (1975/76, Ausstellungskatalog)
TutTS	Tutankhamūn's Tomb Series
TutTS 1	H. Murray–M. Nuttall, <i>A Handlist to Howard Carter's Catalogue of Objects in Tutankhamūn's Tomb</i> (TutTS I, Oxford 1963)
TutTS 2	J. Černý, <i>Hieratic Inscriptions from the Tomb of Tutankhamūn</i> (TutTS II, Oxford 1965)
TutTS 3	W. McLeod, <i>Composite Bows from the Tomb of Tutankhamūn</i> (TutTS III, Oxford 1970)
TutTS 4	W. McLeod, <i>Self Bows and Other Archery Tackle from the Tomb of Tutankhamūn</i> (TutTS IV, Oxford 1982)
TutTS 5	F. F. Leek, <i>The Human Remains from the Tomb of Tutankhamūn</i> (TutTS V, Oxford 1972)
TutTS 6	L. Manniche, <i>Musical Instruments from the Tomb of Tutankhamūn</i> (TutTS VI, Oxford 1976)
TutTS 7	W. J. Tait, <i>Game-Boxes and Accessories from the Tomb of Tutankhamūn</i> (TutTS VIII, Oxford 1982)
TutTS 8	M.A. Littauer–J.H. Crouwel, <i>Chariots and Related Equipment from the Tomb of Tutankhamūn</i> (TutTS VIII, Oxford 1985)
UDSSR	<i>Sokrovica Grobnicy Tutanchamona</i> (Moskva 1972, Ausstellungskatalog)
USA	<i>Treasures of Tutankhamun</i> New York 1976. (Ausstellungskatalog)
USA 61/63	<i>Tutankhamun Treasures</i> , 1961 (Ausstellungskatalog)
Vilímková	M. Vilímková, <i>Altägyptische Goldschmiedekunst</i> (Prag 1969)
Wien	<i>Echnaton. Nofretete. Tutanchamun</i> (Wien 1975, Ausstellungskatalog)

Teil I

Corpus der hieroglyphischen Inschriften
aus dem Grab des Tutanchamun

ZEICHENERKLÄRUNG

* keine Autopsie

Leserichtung beim Original:

→ horizontal von links nach rechts

← horizontal von rechts nach links

↳ vertikal von links nach rechts

↵ vertikal von rechts nach links

↓ vertikal

EXPLANATION OF SIGNS

* not personally examined

Direction of reading on the original:

→ horizontal from left to right

← horizontal from right to left

↳ vertical from left to right

↵ vertical from right to left

↓ vertical

Wände der Sargkammer

Textnachweis: Paris, Falttafel; Romer, S.262.

Ostwand

über der Mumie:

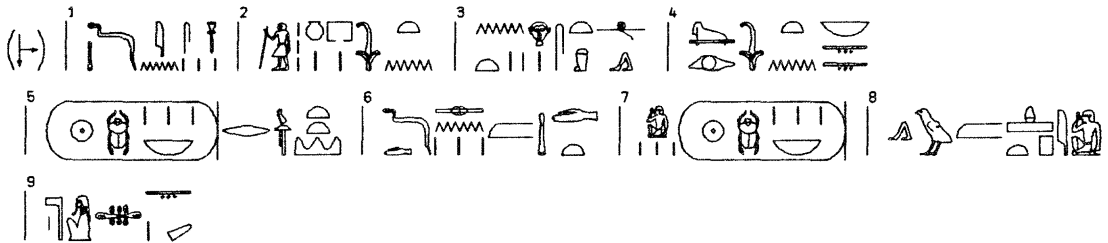

über den Personen, die den Sargschlitten ziehen:

**Nordwand**

Mundöffnungsszene

vor Eje:



vor Tutanchamun:



Begrüßung durch Nut

vor dem König:



vor Nut:



Umarmung des Osiris

Ka-Figur

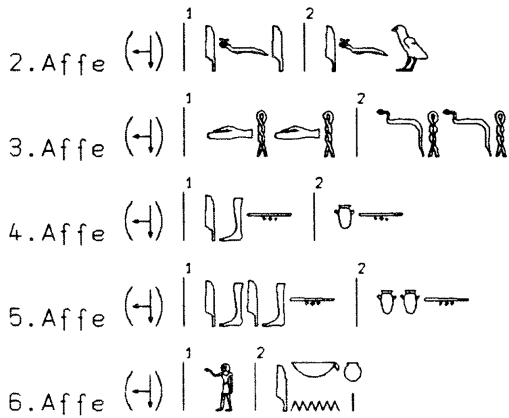

Beischriften zu den sechs Affen auf der linken Wandhälfte:
(Reihenfolge: 1. linke Spalte von oben nach unten, 2. rechte Spalte von oben nach unten. Zeilenabfolge jeweils von links nach rechts.)

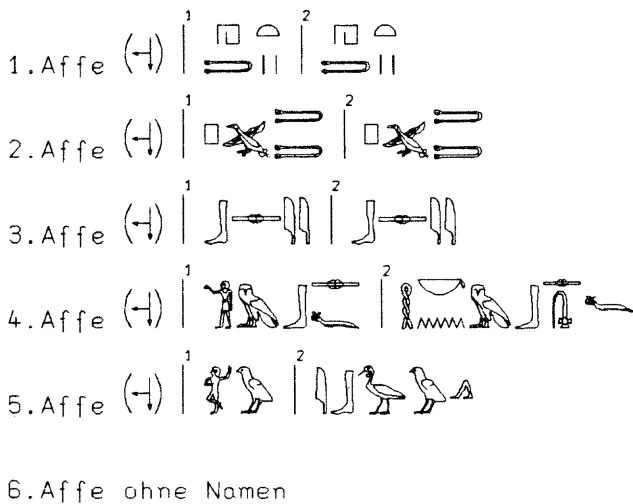

Südwand (Figuren von rechts nach links)

vor der Westgöttin:

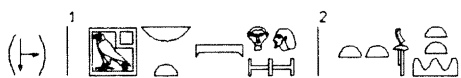

vor dem König:





vor Anubis:

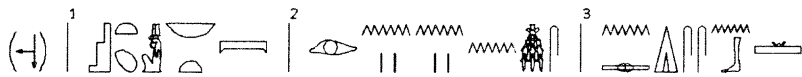

vor Isis:



von der oder den nachfolgenden Zeilen ist nichts mehr erhalten, nur direkt rechts von dem  auf dem Kopf der Isis ist noch eine Zeilenbegrenzung zu sehen und in der Zeile der Rest eines , evtl. von einem zu ergänzenden . Davor drei hockende Götter mit jeweils der gleichen Inschrift:



1a - Skarabäus*

nach Zeichnung in Oxford:

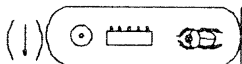

1k - Holzkasten

einzelner Knopf 

Deckel

oberer Knopf: 

Längsreihe:

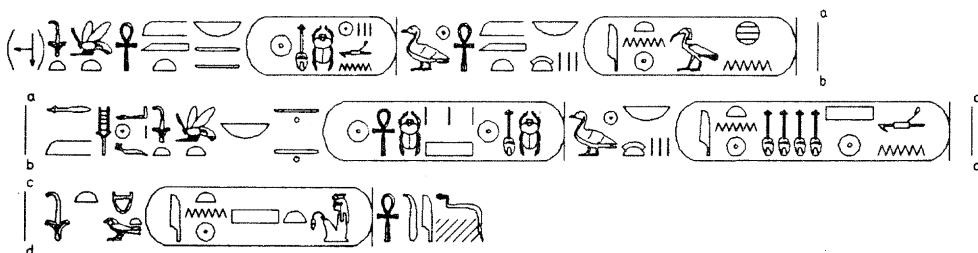

hieratische Inschrift TutTS 2, Nr.46

1l - Holzkasten

hieratische Inschrift TutTS 2, Nr.47.

zwei Holzknöpfe jeweils mit 

3 - Siegel von Weinkrügen

Siegel:



4 - Siegel, Typ "A", "B", "C", "D", "E"

5c - Siegel:



7 - Alabaster-Gefäß

hieratische Inschrift TutTS 2, Nr.39

7a - Alabaster-Gefäß

hieratische Inschrift TutTS 2, Nr.40

7b - Alabaster-Gefäß

hieratische Inschrift TutTS 2, Nr.41

10 - Siegel

Siegel:



11 - Weinkrug

hieratische Inschrift TutTS 2, Nr.21

14 - Alabaster-Kelch

Textnachweis: Edwards, S.26f.; Seton-Williams, Abb.135; Paris, Nr.42.



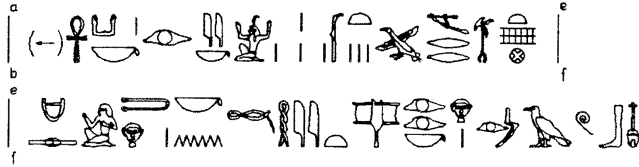

auf dem Bauch des Kelches:

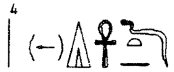
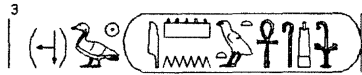

14b - Holzkasten in Kartuschenform

Textnachweis: USA 61/63, Nr.29.

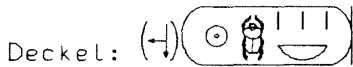

20 - Alabaster-Gefäß

hieratische Inschrift TutTS 2, Nr.42

21 - bemalte Holztruhe

Textnachweis: Davies

Deckel:

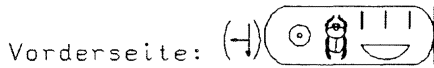

Zentrale Inschrift:

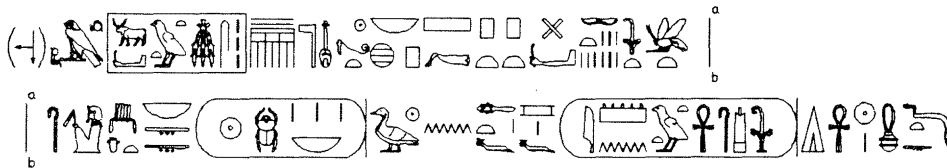

auf dem Deckelknopf scheint  gestanden zu haben.

vor dem König:

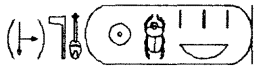

über dem König:



Kasten

Vorderseite:

links u. rechts der geflügelten Sonnenscheibe:

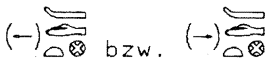

die zentralen Kartuschen:

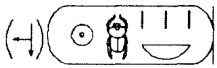



vor der linken Sphinx:

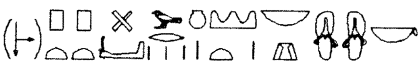

darüber: (-) 

vor der rechten Sphinx:



darüber: (-) 

auf dem Knopf  ?

Königsnamen auf den Fächern

vor dem König:

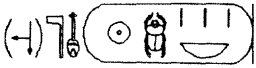

unter dem rechten Geier: (H)

21n - Holztafel

hieratische Inschrift TutTS 2, Nr.61

21t - Pantherkopf

Kartusche auf der Stirn:

21ff - Stoff

ein Ende:



anderes Ende ebenso

21gg - Stoff

unten links: (H) ¹ ² ³ ⁴

unten rechts: (H) ¹ ²

22 - Königs-Statue

auf dem Schurz (Gürtelschnalle): (H)

auf der Rückseite des Gürtels: (H) (der Käfer hat Flügel).

auf dem Schurz (Mitte):

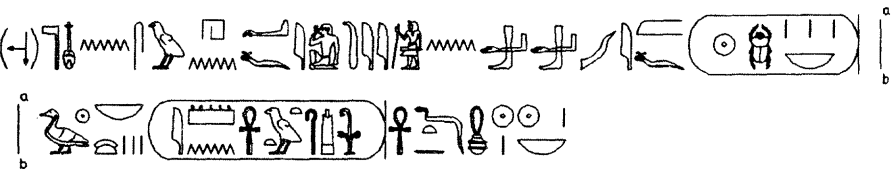

Seite B, linke Hälfte

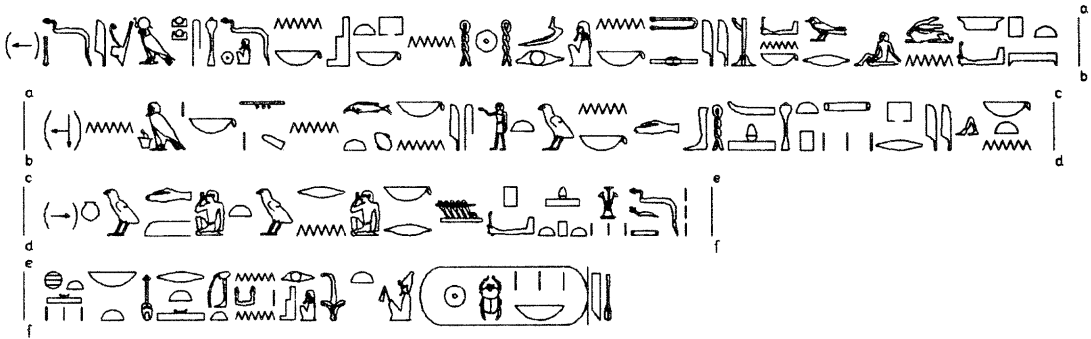

Seite B, rechte Hälfte



Seite C, linke Hälfte

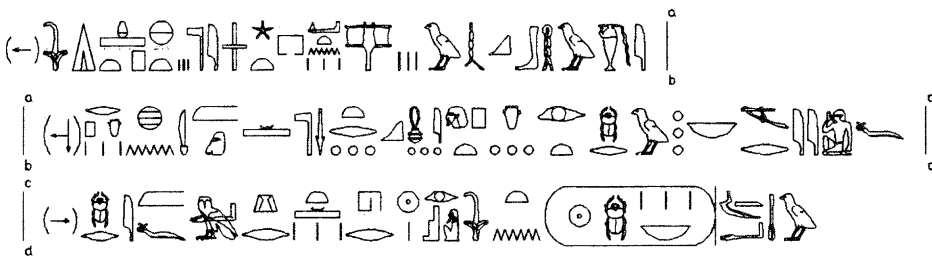

Seite C, rechte Hälfte

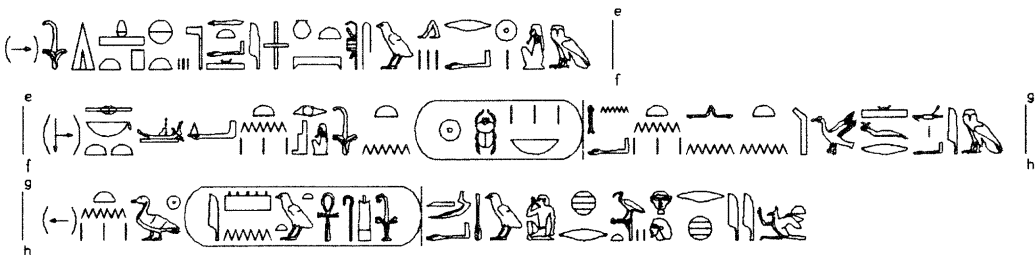

Seite D, linke Hälfte

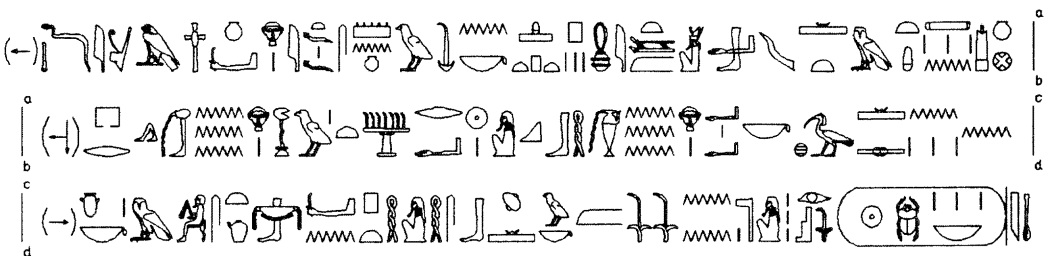

Seite D, rechte Hälfte



Deckel

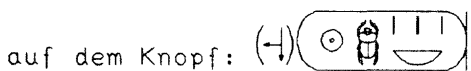

Text 1

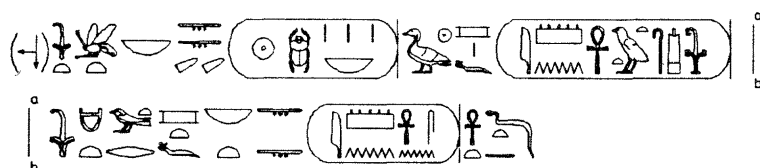

Text 2



Text 3

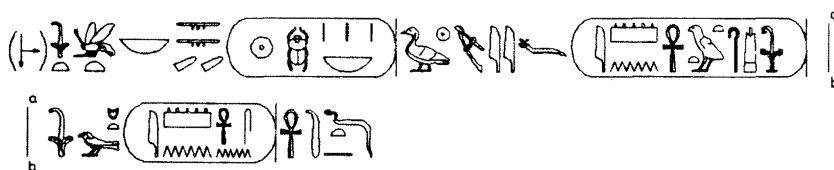

Text 4

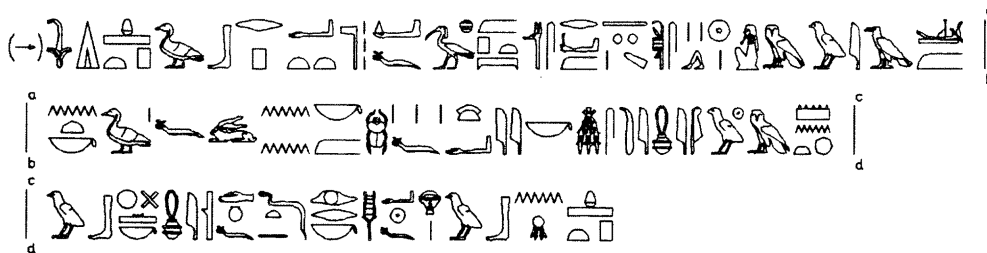

Text 5



38a - Siegel, Typ "L"

38b - Schlange auf Standarte

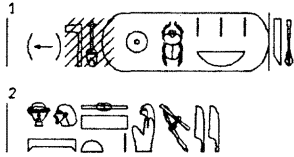

40 - Alabaster-Truhe

Textnachweis: Seton-Williams, Abb.140; Edwards, S.71.

Vorderseite:

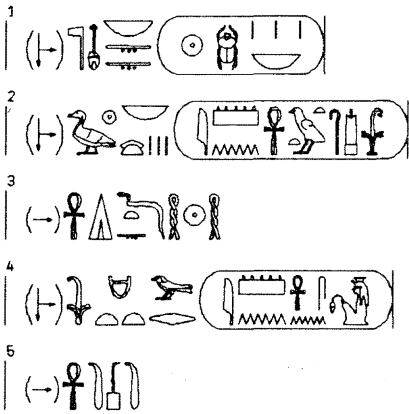

Zeile 3 und 5 bilden eine einzige Zeile unter den Königsnamen

auf dem Deckel:



44 - Truhe

Textnachweis: Seton-Williams, Abb.141.

7x (H) symbol, a seated figure, a bowl, a seated figure, a bowl | Nr. 1, 3, 5, 9, 11, 13, 15

3x (H) symbol, a snake on a stand, a bowl, a seated figure, a bowl, a staff, a staff | Nr. 2, 4, 14

3x (H) symbol, a snake on a stand, a bowl, a seated figure, a bowl, a staff, a staff | Nr. 10, 12, 16

auf der Vorderseite (6 u.7):

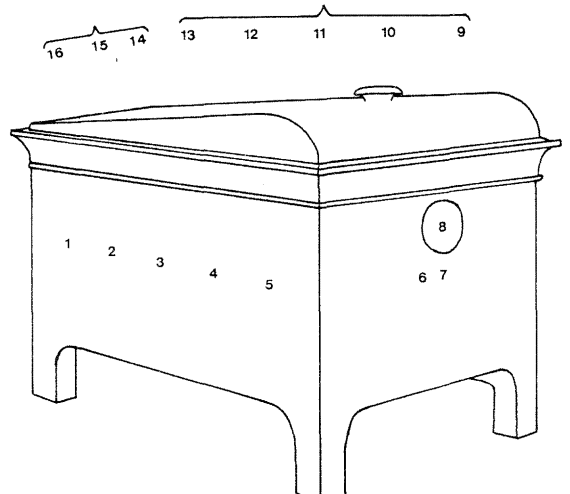
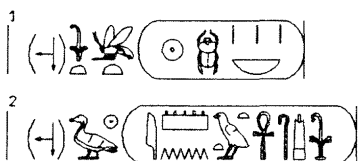



auf dem Knopf der Vorderseite (8):

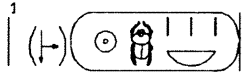

Deckel:

links:



rechts:



zentrale Inschrift:



auf dem Knopf des Deckels:

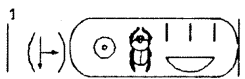

44a - 4 Goldspangen (3 mit Inschriften)

Thronszene



links von der Kartusche, wohl zugehörig:

rechts von der Kartusche und darunter - wohl als Worte des oben

fliegenden Raubvogels:

zwischen den Flügeln der links stehenden Göttin:

darüber: und

über bzw. neben Harachte:

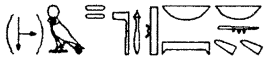

über bzw. neben Atum:



44p - Dächsel



44q - Panther-Kopf und zugehörige Stücke

Textnachweis: Deutschland 80/81, Nr.13.



zwei Kartuschen und mehrere Sterne mit:



44s - Holzschale

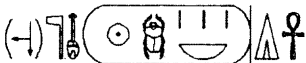

44w - Kleid

zwei Plättchen mit jeweils beiden Kartuschen

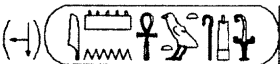
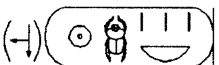

44gg - Skarabäus

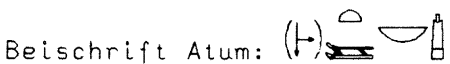

46b - Halskragen

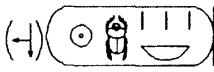
viele Fayence-Plättchen mit 

46y - Isis-Blut-Amulett

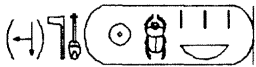

46gg - runde Gold-Plättchen (mehrere Stücke)

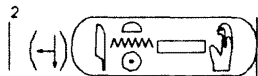

46ll - zwei Stücke einer Wagen-Verzierung:

zwischen links und rechts jeweils  stehen zwei Kartuschen:

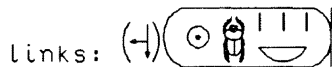

47 - Ebenholz-Liege

Textnachweis: Seton-Williams, Abb.126f.

linke Seite

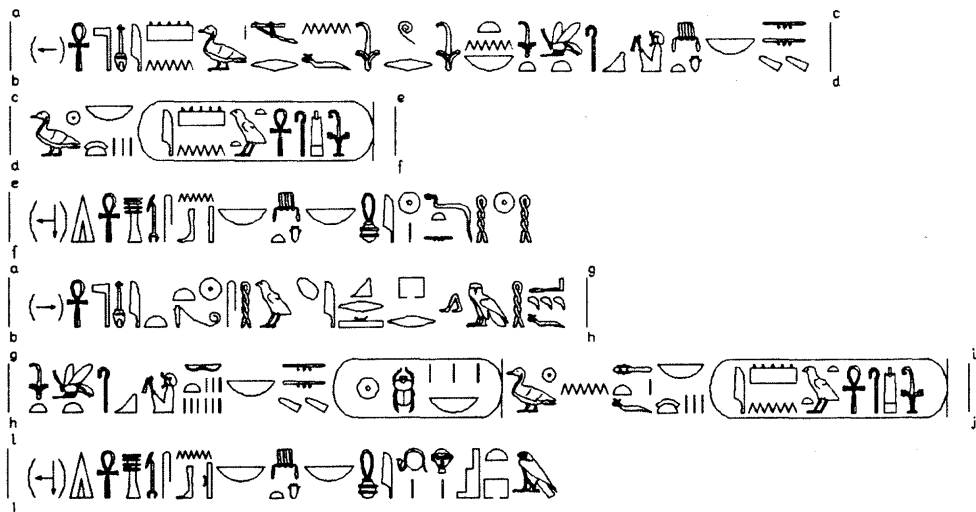

48a - gebogener Stock

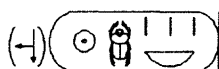
am oberen Ende: 

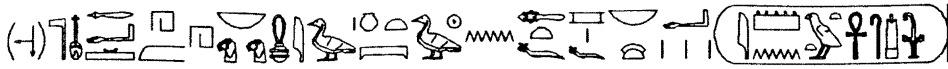

48h - Bogen

Textnachweis: TutTS 3, Nr.4.

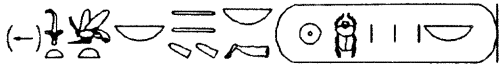

unter der Kartusche sieht man Reste von

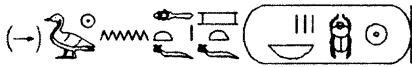

unter der Kartusche sieht man Reste von

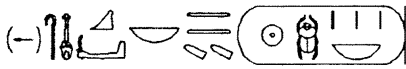

48i (1) - Bogen

Textnachweis: TutTS 3, Nr.5.

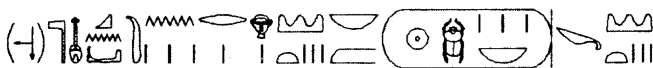
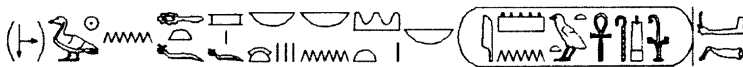

48i (2) - Bogen

Textnachweis: TutTS 3, Nr.6.



48j (1) - Bogen

Textnachweis: TutTS 3, Nr.7.

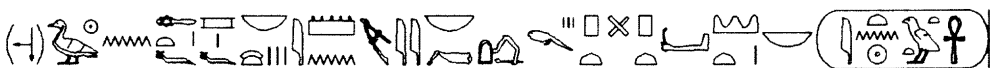

48j (2) - Bogen

Textnachweis: TutTS 3, Nr.8.



48k (1) - Bogen

Textnachweis: TutTS 3, Nr.9.

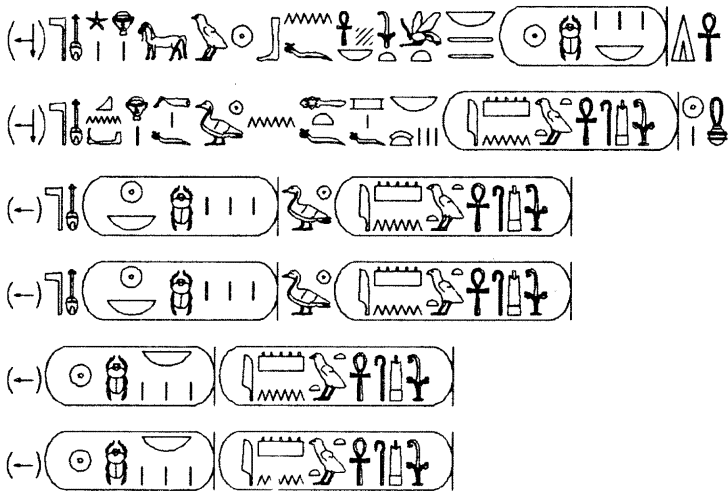

48k (2) - Bogen

Textnachweis: TutTS 3, Nr.10.

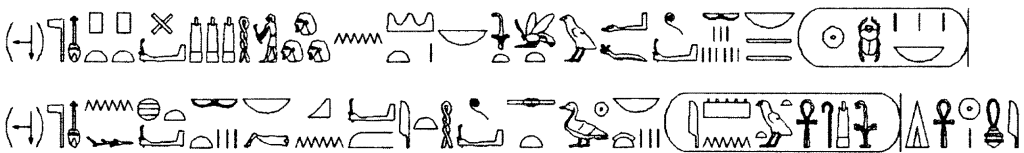

48l - Bogen

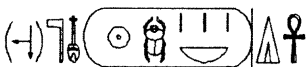

48o - Stock

auf dem Knauf:

48p - Stab

2x das Kartuschenpaar:

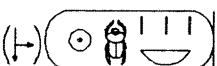

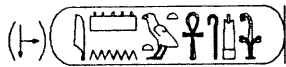

48q - Stock

auf dem Knauf:

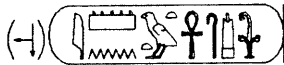
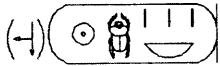

drei umlaufende Bänder:

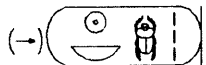

48s - Stab

Band:

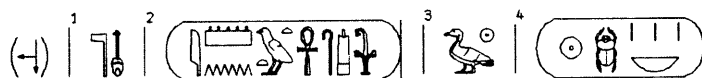

48w - Stock

auf dem Knauf: (→) (circle with dot, cartouche, smile) flankiert von 7 and 8

auf dem Schaft zwei Bänder mit jeweils drei Kartuschen:

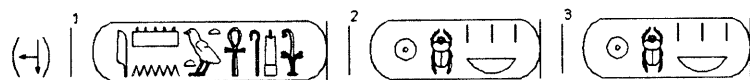

50 - Kasten

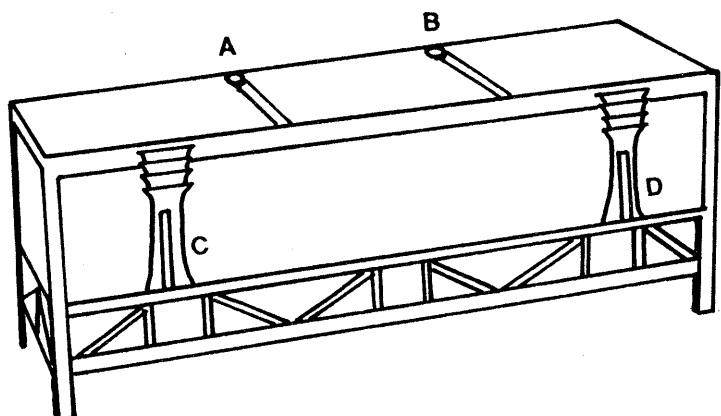

50xx - Stab

Kartuschen auf dem Knauf:

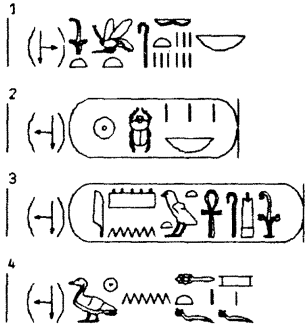

Kartusche an der Seite des Knaufs (mehr nicht zu sehen):



am Schaft:

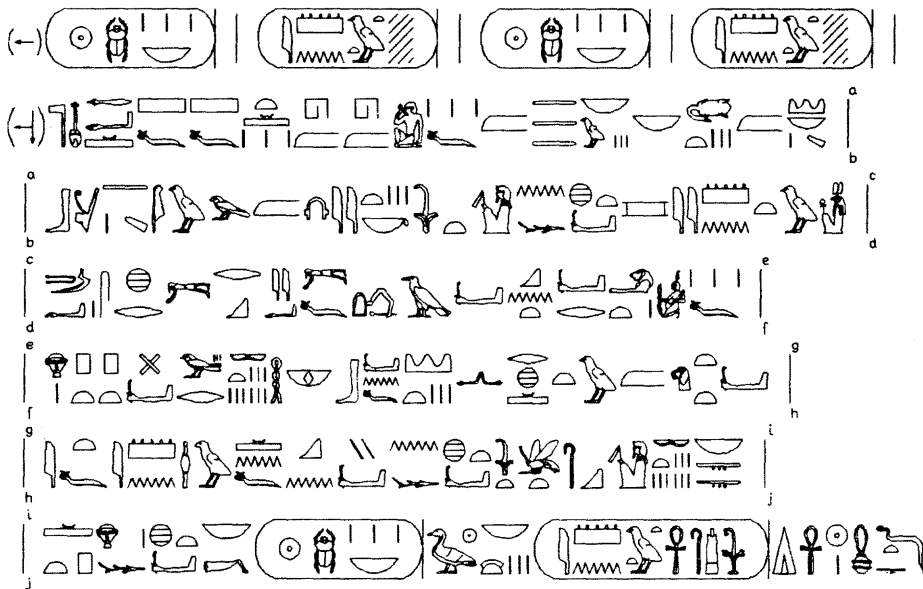

53b - Ringe

6 Exemplare: (-) [Cartouche 2] | 1 Exemplar: (-) [Cartouche 3]

2 Exemplare: (-) [Cartouche 1] [Cartouche 4]

54 - Holzkasten

hieratische Inschrift TutTS 2, Nr.48

auf den beiden Knöpfen jeweils: (-) [Cartouche 2]

54d - Wurfholz

am Schaft: (-) 

andere Seite:*  (nach Beschreibung)

am unteren Ende: (-) 

54e - Wurfholz

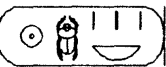
am Schaft: (-) 

andere Seite:*  (nach Beschreibung)

am unteren Ende: (-) 

54k - Pektoral

Textnachweis: Saleh, Hauptwerke Kairo, Nr.191.

über Amun:

(+) ¹  ²  ³ 

vor dem König:

(+)    



ist unsicher.

über Atum:

(+) ¹  ² 

über Ius-aes:

(+) ¹  ² 

54n - Fayence-Schale

(+) 

54t - Fayence-Napf



54u - Fayence-Napf



54w - Fayence-Vase

Inschriften (2 Kartuschen) bis auf wenige Reste abgerieben.

54z - Fayence-Libationsgefäß

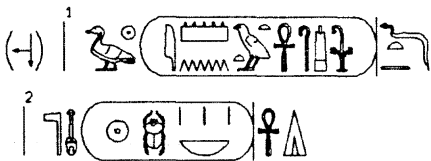

54aa - Fayence-Libationsgefäß

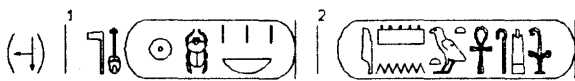

54hh - Deckel eines Holzkästchens



54rr - zwei Fayence-Becher



54bbb - Fayence-Libationsgefäß



54ccc - Fayence-Vase

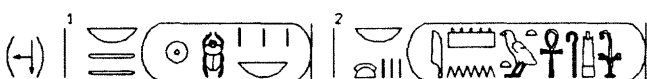

54ddd - Schmuck-Kästchen

Textnachweis: Le monde égyptien II, S.212.

Vorderseite:

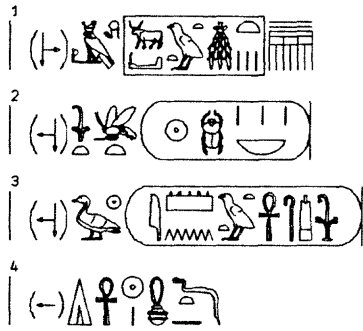

3	2	1
4		

Deckel:



hieratische Inschrift TutTS 2, Nr.49

54ddd (3) - Elfenbein-Griff

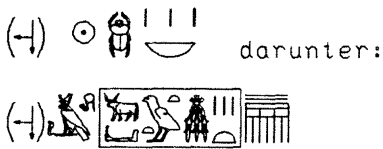

55 - Alabaster-Gefäß

hieratische Inschrift TutTS 2, Nr.44

57 - Alabaster-Gefäß

Textnachweis: Le Musée du Caire, Abb.118.

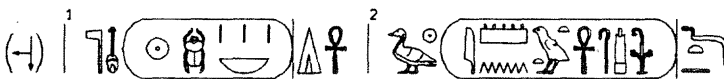

60 - Öl-Gefäß

Textnachweis: Deutschland 80/81, Nr.34.



61 - Alabaster-Vase

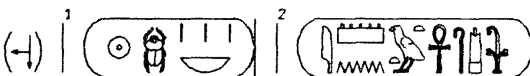

62a-vv - Holzkästen für Nahrung

28 Holzkästen mit hieratischen Inschriften, TutTS 2, Nr.78 bis 87

Schriftband an der linken Seite:



Schriftband an der rechten Seite:

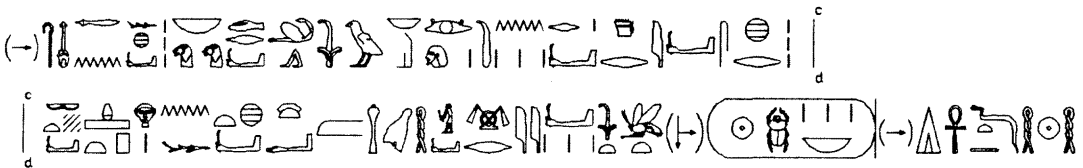

Schriftband an der Rückseite:



Deckel:

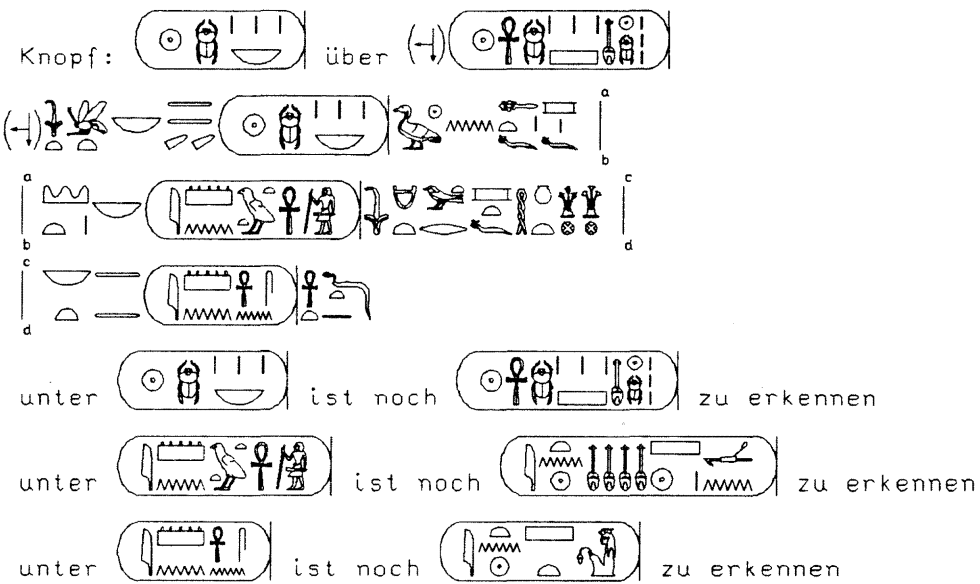

hieratische Inschrift TutIS 2, Nr.58

87 - Stuhl

Textnachweis: Seton-Williams, Abb.121; Edwards, S.43; Japan, Nr.43.

Lehne, Vorderseite

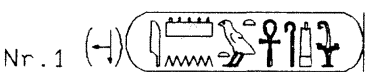

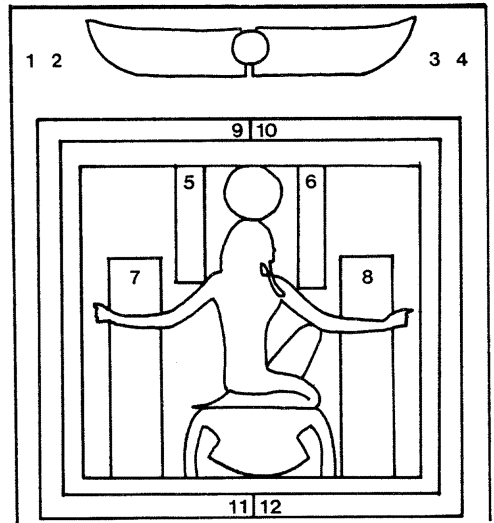
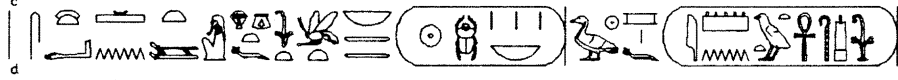
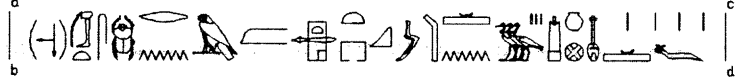
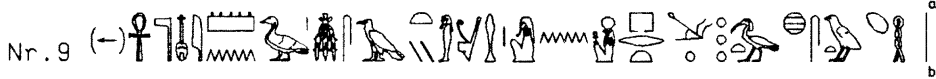
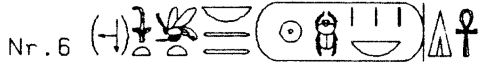
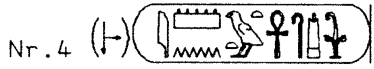
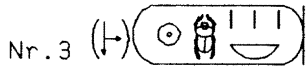
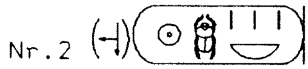

Lehne, Rückseite

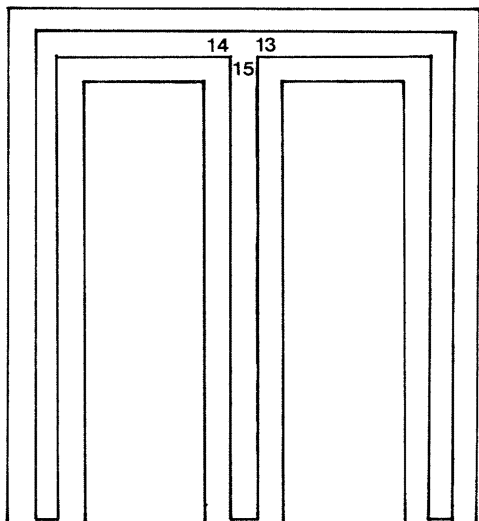

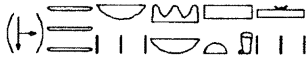

Die Hieroglyphen bilden keine zusammenhängenden Zeilen.

90 - Fuß-Schemel zum Thronsessel

Textnachweis: Seton-Williams, Abb.122

Oberseite:

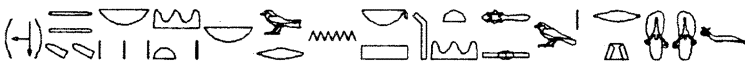

Vorderseite: (H)

Rückseite: (H)

91 - Thronsessel

Textnachweis: Fox, Schatz, Abb.11; Fox, Treasure, Abb.9;
Lange-Hirmer, Taf.194; Seton-Williams, Abb.122;
Carter II, Taf.50 (pl.62-64).

Rücklehne, Vorderseite:

oben, links vom Aton:

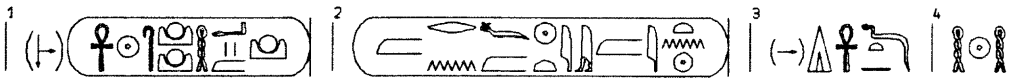

oben, rechts vom Aton:

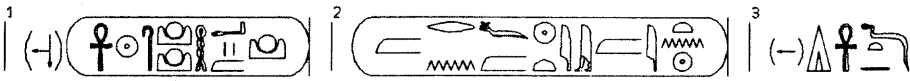

über dem König:

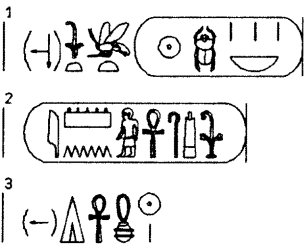

über der Königin:

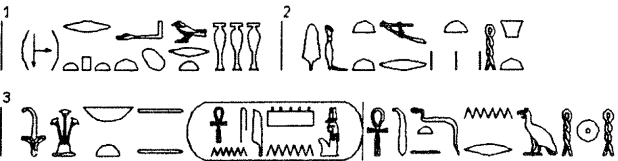

linke Armlehne, außen:



linke Armlehne, innen:



rechte Armlehne, außen:

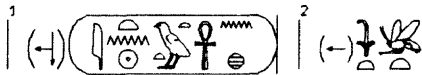

rechte Armlehne, innen:



Rückseite:

links:



Mitte:



rechts:



2 hieratische Inschriften am linken hinteren Stuhlbein (heute

nicht mehr zu sehen):

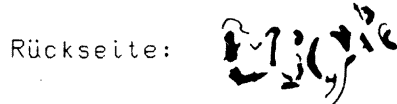
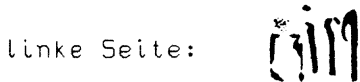

98 - Stab

zwei umlaufende Bänder:

Nr. 1:





Nr. 2:

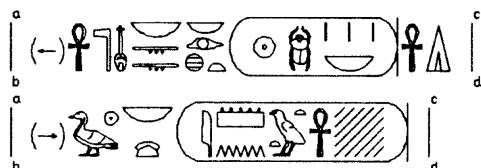

99a - Anch-Amulett

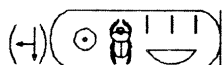

100a - Stab mit gebogenem Ende

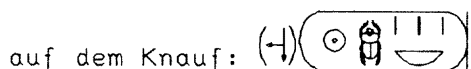

100f - Leinenstreifen

aufgesetzt zwei Rechtecke aus Stoff mit je 2 Kartuschen



in der Mitte zu erkennen:

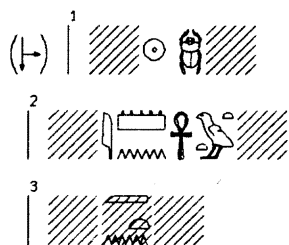

davon unabhängige Zeile:

101 - Truhe

Vorderseite:

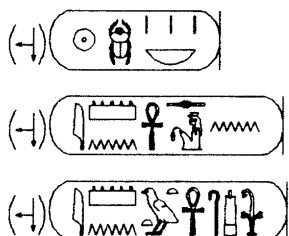

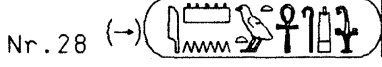
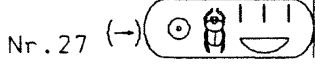
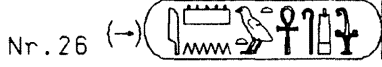
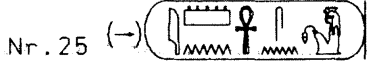
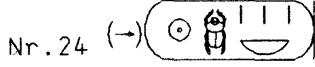
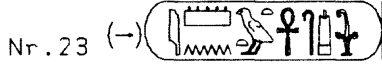
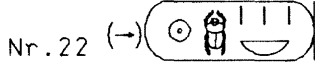
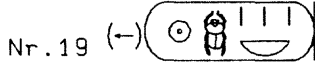
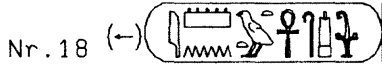

links und rechts der geflügelten Sonnenscheiben:



Vorderseite:

links und rechts der geflügelten Sonnenscheiben:



linke Ecke:

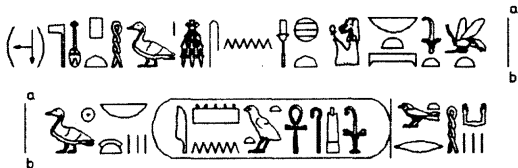

rechte Ecke:

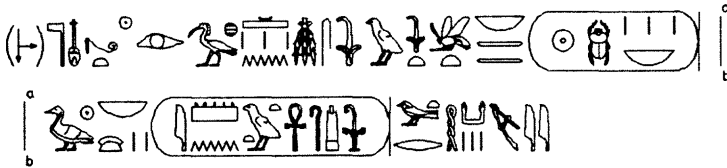

Beischriften auf der Tür:

linker Türflügel

oben: 

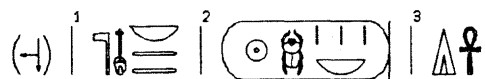

Mitte: 

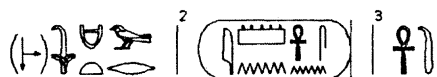

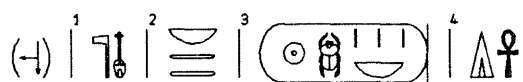
unten: 



rechter Türflügel

oben: 



Mitte: 

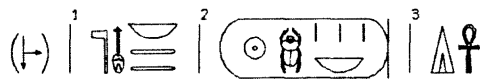

unten: 



Türflügel von innen:

linker Türflügel:

oben: 

Mitte: 

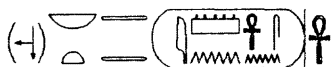

unten: 

rechter Türflügel:

über der Königin:

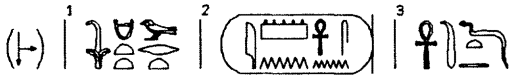

vor dem König:

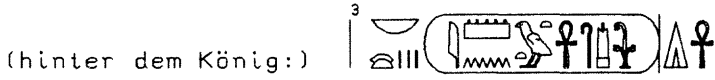

Rückseite des Schreins, Randinschrift:

linke Seite:

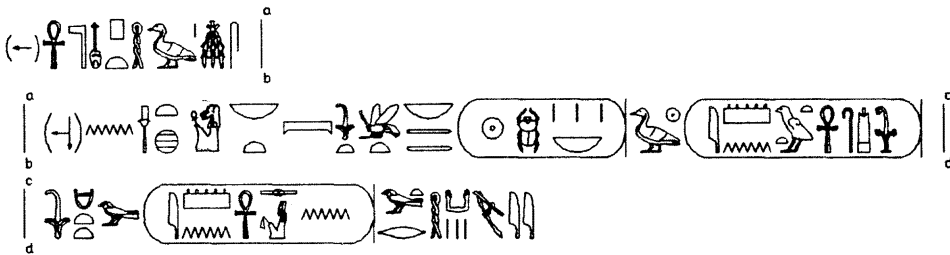

rechte Seite:

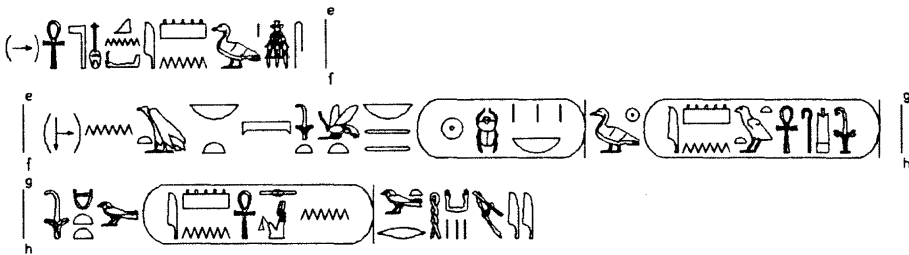

Beischriften obere Szene:

vor bzw. hinter dem König:

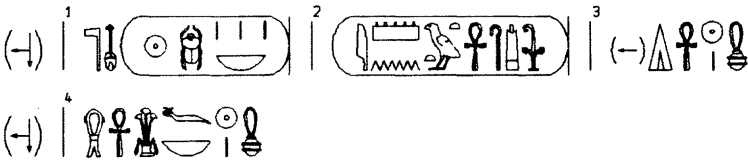

hinter der Königin:



Beischriften untere Szene:

vor bzw. hinter dem König:

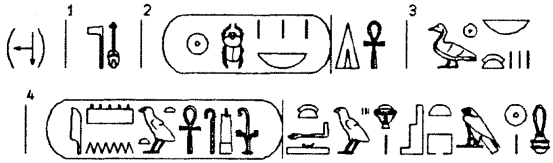

hinter der Königin:

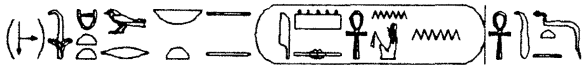

rechte Seite des Schreins:

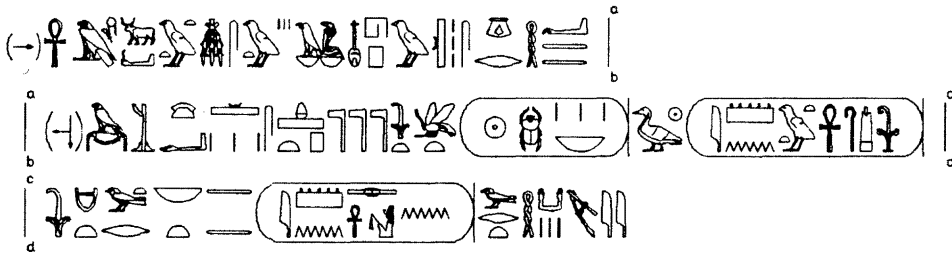

senkrechte Inschrift am linken Rand:



Beischriften

Szene oben links:

über dem König:

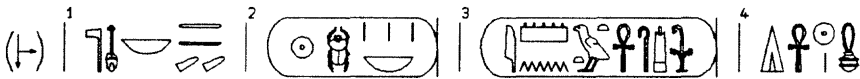

über der Königin:



Vor der Königin:



Szene oben rechts:

über dem König:

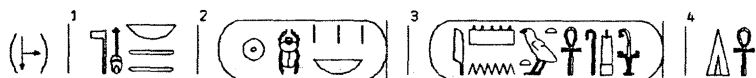

über der Königin:

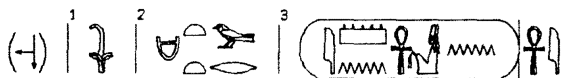

Szene unten links:



über und hinter der Königin:

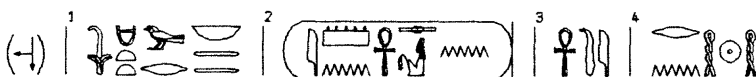

Szene unten rechts:

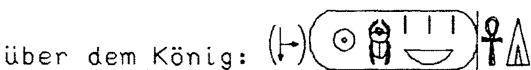

über und hinter der Königin:

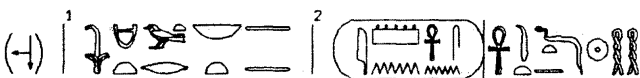

108a - Podest für Goldstatue

Textnachweis: Small golden shrine, Taf.5.

Vorderseite:

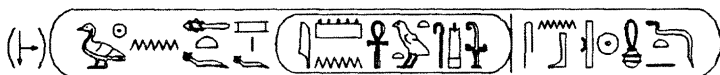

Rückseite:

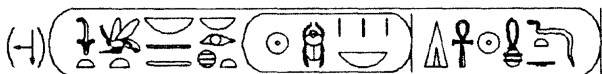



108c - Kette mit Anhänger



Textnachweis: Small golden shrine, Taf.7.



Nach Ansicht von Graefe/Eaton-Krauss steht unter dem ☐ : □ △ , so daß "Herrin des Himmels" zu übersetzen wäre. Ein solcher Beiname der Weret-Hekau ist zwar belegt, die Hieroglyphen am

Original sehen aber doch eher wie  oder wie

 aus. Diese Schreibung könnte auf 

oder  zurückgehen. Wenn  beabsichtigt

gewesen wäre, hätte man bei Platzmangel eher  geschrieben.

R.Hari liest (JEA 62,1976,S.100) die fragliche Stelle als: 

110/60825 - Uschebti

Textnachweis: UDSSR, Nr.14; Paris, Nr.32.

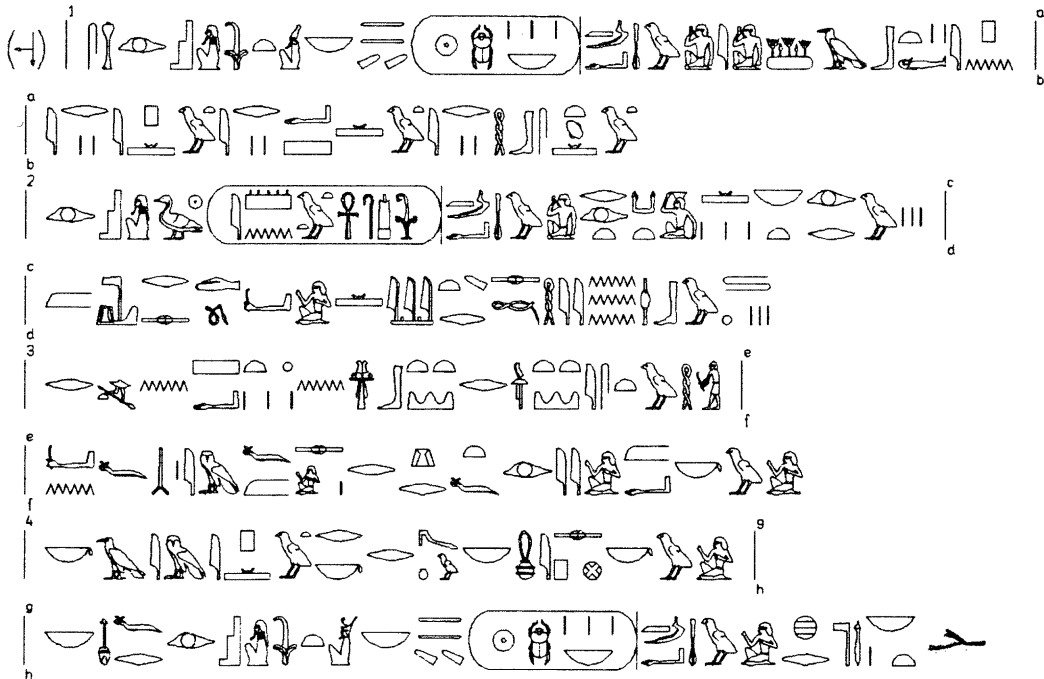

119 - Leinen-Stück *

Siegel, Typ "0"

120 - Wagen

Textnachweis: TutTS 8, Taf.16-21.

Innenseite:

Zentrum, links:

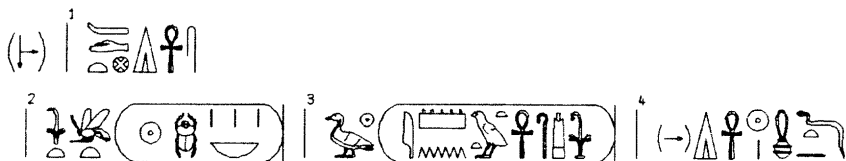

Zentrum, rechts:

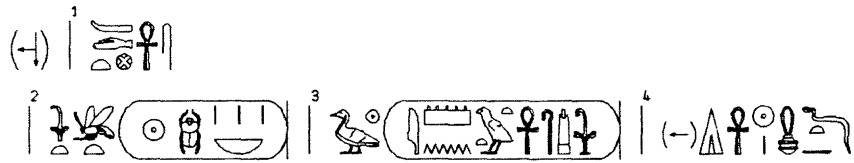

Innenseite, linker Flügel:

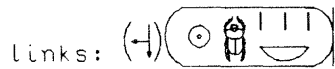
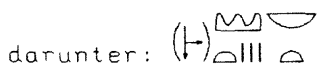
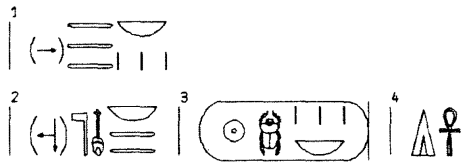

unter der Geierdarstellung:

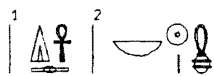

Innenseite, rechter Flügel:

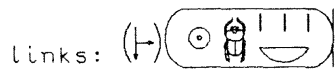
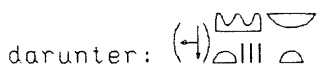
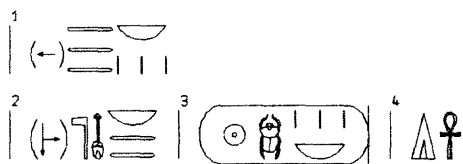

unter der Geierdarstellung:

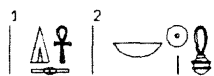

Außenseite, links:



Außenseite, rechts:

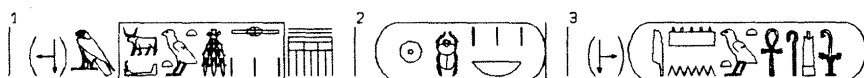

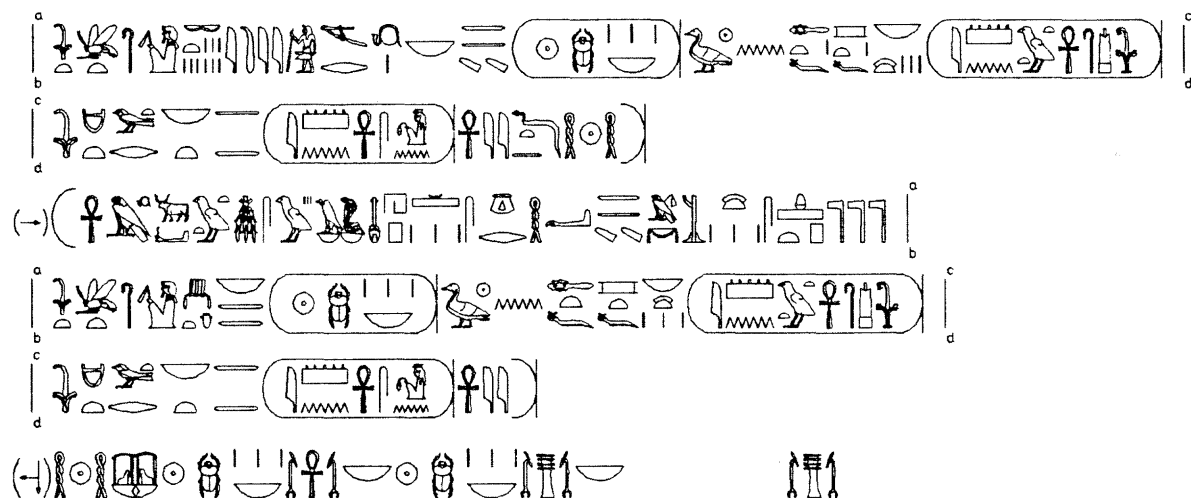
**122... - Blattgoldstücke:**

Textnachweis: TutTS 8, Taf.41-49.

die Stücke x bis iiii wurden nicht im einzelnen am Original überprüft. Auf den vorhandenen Photos sind gleichartige Stücke nur einmal abgebildet und mit entsprechend viel Nummern versehen. Dadurch ist nicht zu entscheiden, welches Stück eigentlich abgebildet ist. Die Abschriften werden hier jeweils für die entsprechenden Stücke wiederholt.

x: König erschlägt Feinde:



y: König erschlägt Feinde:



hinten dem König: (-) | |

z: König ersticht Löwen (2x):

Kartuschen im Zentrum:



linke Szene:



rechte Szene:



aa: König erschlägt Feind:

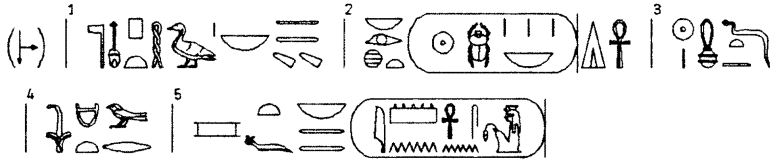

bb: König thronend:

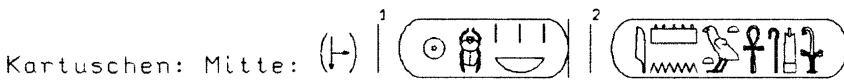

Kartuschen: Mitte:

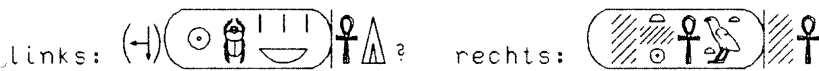

cc: König auf Streitwagen:

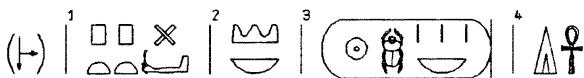

dd: König auf Streitwagen:

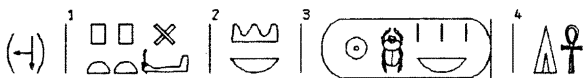

ee: König als Sphinx tritt Feinde nieder:

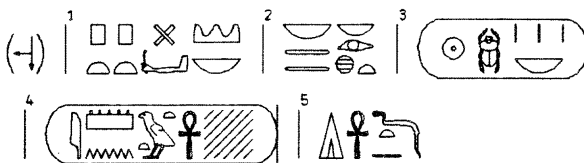

ff: König auf Streitwagen:

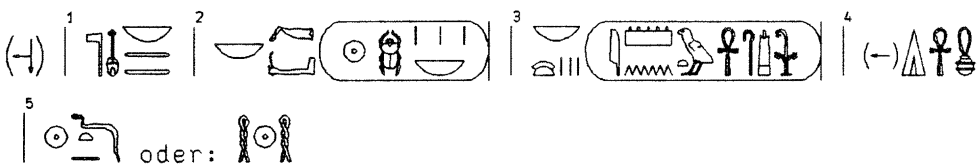

hh: König auf Streitwagen:



ii: Löwe tritt Feinde nieder:



jj: Löwe tritt Feinde nieder:

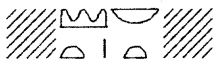

kk: Löwe tritt Feinde nieder:

wie JJ, aber stark zerstört. Erhalten ist nur: 

ll: Klagender Asiate und Neger:



nn: Klagender Asiate und Neger:



oo: Klagender Asiate und Neger:



pp: Klagender Asiate und Neger:



ss: zwei senkrechte Kartuschen nebeneinander, flankiert von zwei



links:  rechts: 

tt: zwei senkrechte Kartuschen nebeneinander, flankiert von zwei



links:  rechts: 

uu: zwei Kartuschen von knienden Feinden flankiert:

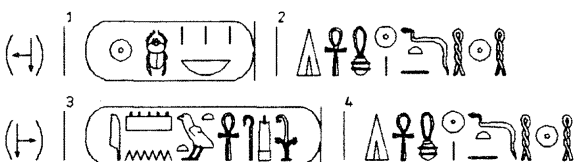

vv: zwei Kartuschen von knienden Feinden flankiert:

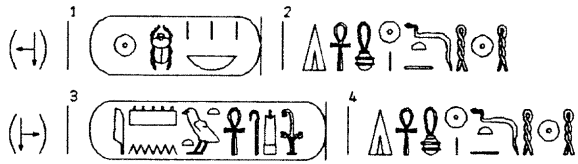

ww: vier senkrechte Zeilen (von links nach rechts):

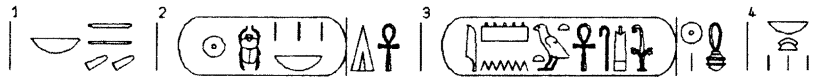

xx: vier Zeilen nebeneinander:



zz: zwei senkrechte Kartuschen nebeneinander, flankiert von zwei



aaa: zwei senkrechte Kartuschen nebeneinander, flankiert von zwei



iii: Löwe zertritt Feinde:

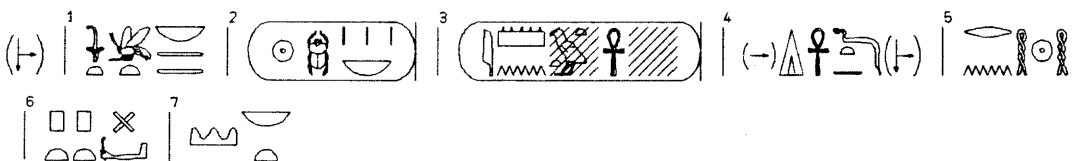

kkk: drei senkrechte Kartuschen, die jeweils von rechts von einem

Falken beschützt werden (von links nach rechts):

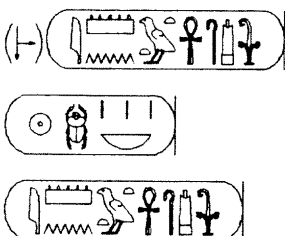

lll: König als Sphinx zertritt Feinde:



mmm: König als Sphinx zertritt Feinde:

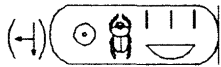

nnn: Löwe zertritt Feinde:

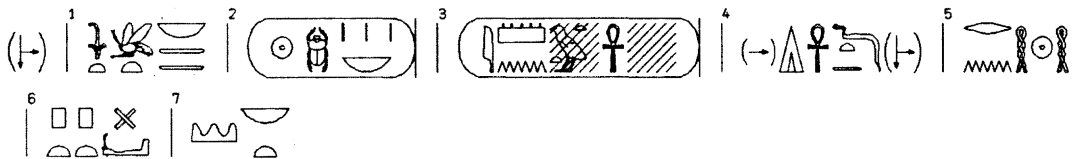

ooo: drei senkrechte Kartuschen, die jeweils von rechts von einem

Falken geschützt werden (von links nach rechts):

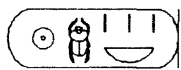

ppp: drei senkrechte Kartuschen, die jeweils von rechts von einem

Falken geschützt werden (von links nach rechts):



qqq: drei senkrechte Kartuschen, die jeweils von rechts von einem

Falken geschützt werden (von links nach rechts):

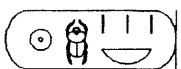

rrr: zwei Kartuschen



darunter die beiden senkrechten Kartuschen nebeneinander:



sss: wie RRR (nach Beschreibung)

ttt: einzelne Kartusche:

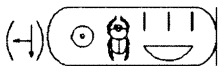

uuu: einzelne Kartusche:

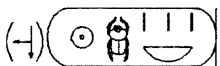

vvv: einzelne Kartusche:

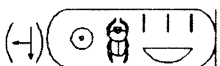

www: gebundene Feinde:

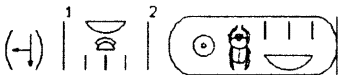

yyy: zwei Kartuschen:

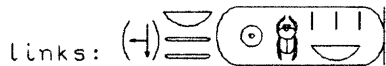

links von den Kartuschen: (-) | (circle) | (bird) rechts: (-) | (triangle) | (bird)

zzz: zwei Kartuschen:



links von den Kartuschen: (-) | (circle) | (bird) rechts: (-) | (triangle) | (bird)

aaaa: zwei Kartuschen:

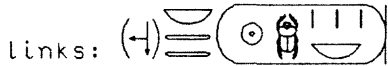

links von den Kartuschen: rechts:

eeee: zwei Kartuschen:

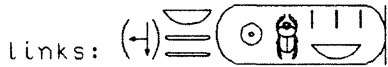

links von den Kartuschen: rechts:

ffff: zwei Kartuschen:

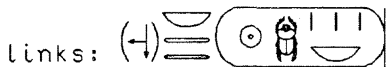

links von den Kartuschen: rechts:

hhhh: mehrere von Falken und Schlangen geschützte Kartuschen:

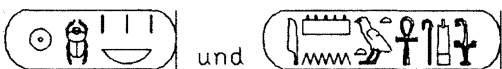

iiii: mehrere von Falken und Schlangen geschützte Kartuschen:



oooo.... zenkrechte Zeilen

(Rekonstruktion des Textes oooo - oooo (34))

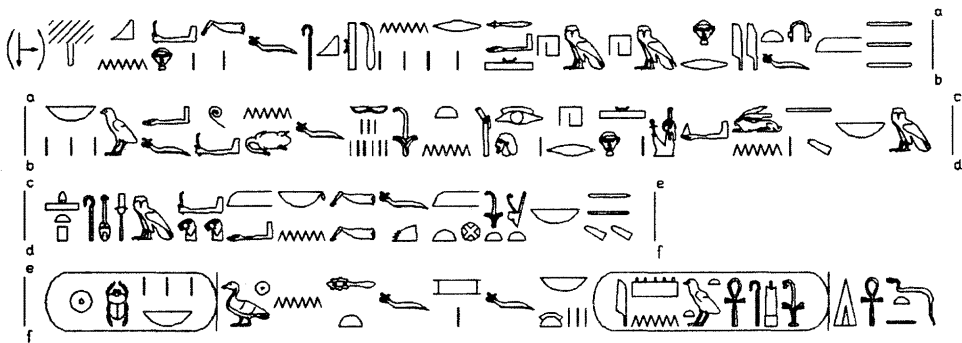

122 oooo

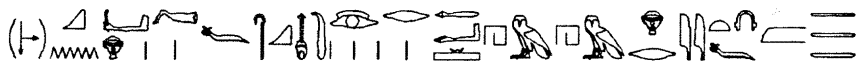

122 oooo (1)



122 oooo (2)



122 oooo (3)



122 oooo (4)



122 oooo (5)

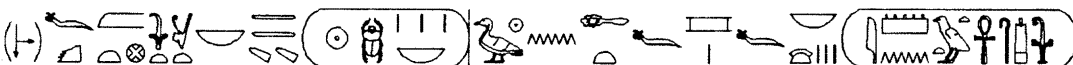

122 oooo (6)

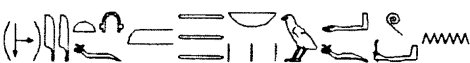

122 oooo (7)



122 oooo (8)

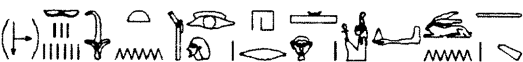

122 oooo (9)



122 oooo (10)



122 oooo (11)

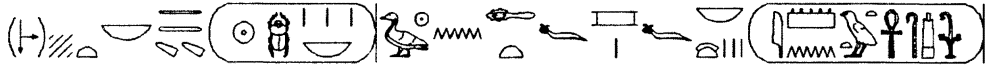

122 oooo (12)

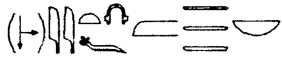

122 oooo (13)



122 oooo (14)



122 oooo (15)



122 oooo (16)



122 oooo (17)

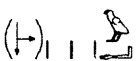

122 oooo (18)



122 oooo (19)

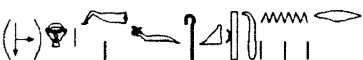

122 oooo (20)



122 oooo (21)

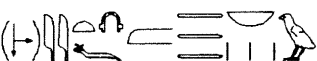

137 - Nilpferd-Bahre

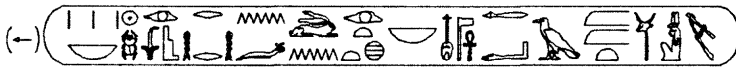

auf dem linken Nilpferdkopf steht innen ein 

138 - Schlangenkopf-Amulette

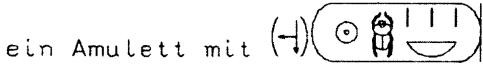

147b - Ringe auf Papyrusstück

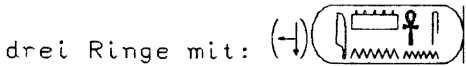

150 - Holzstreifen von einem Wagen

Textnachweis: TutTS 8, Taf.51.

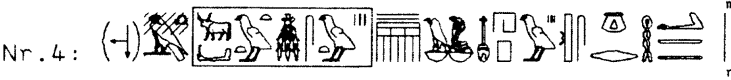
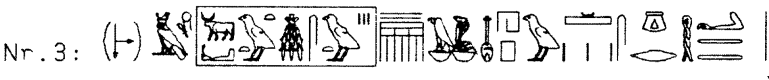
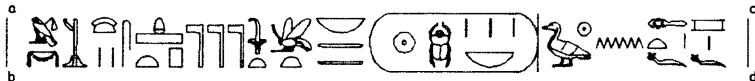

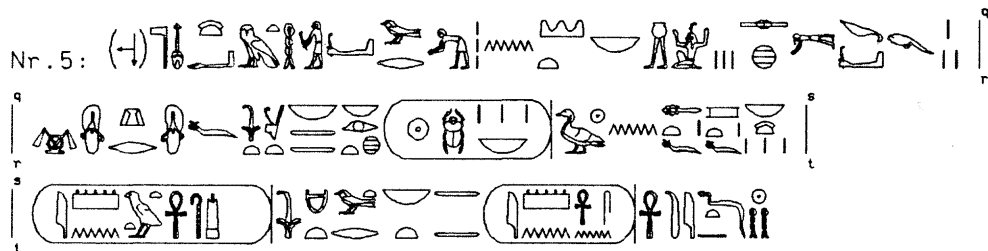

153 - Bogen

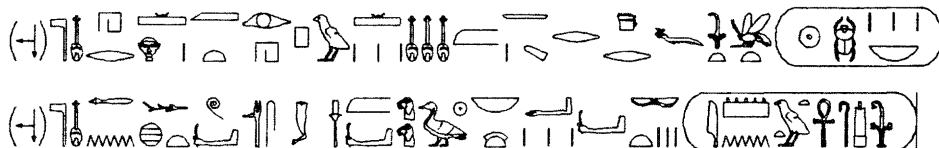

153a - Fayence-Ring



173 - Alabaster-Vase

außen, Vorderseite:

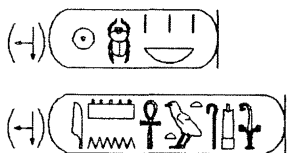

außen, Rückseite:

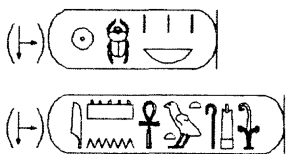

innen, vorn:

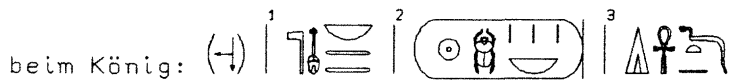

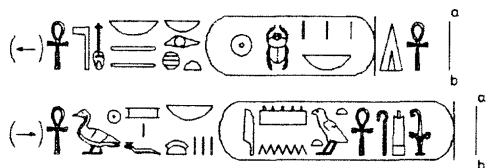

innen, hinten:

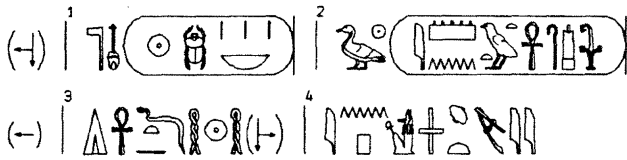

202 - Imiut**204 - Stab**

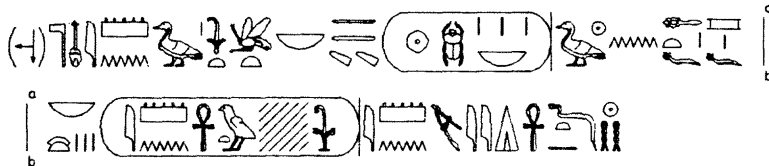
am Schaft:



anstelle der drei Amun-Namen stand ursprünglich  da

auf der Oberseite der Papyrusdolde (umlaufend):

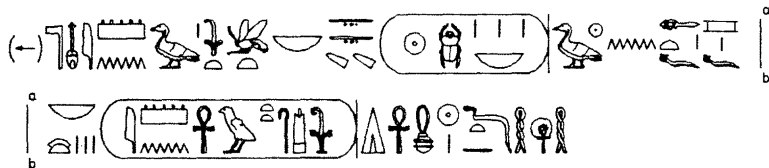
**206 - Weinkrug**

hieratische Inschrift TutTS 2, Nr.13

207 - äußerer Schrein

s. Piankoff, S.7 - 22

210 - Parfum-Gefäß

Textnachweis: Seton-Williams, Abb.139; Edwards, S.98f.

am Hals:

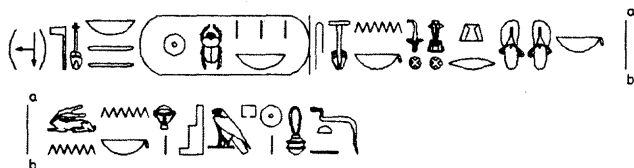



am Bauch:

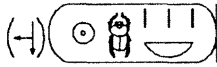

links um die Schlange herum verteilt; 

am Podest:

vorn und rechts jeweils: 

links: 

rechts: 

211 - Salbgefäß (liegender Löwe)

Textnachweis: Edwards, S.95; Deutschland 80/81, Nr.49.

auf dem Rücken des Löwen: 

auf der Säule links, Scharnierseite:



auf der Säule rechts, Verschußseite:



213 - Stab

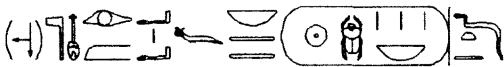

224 - Stab

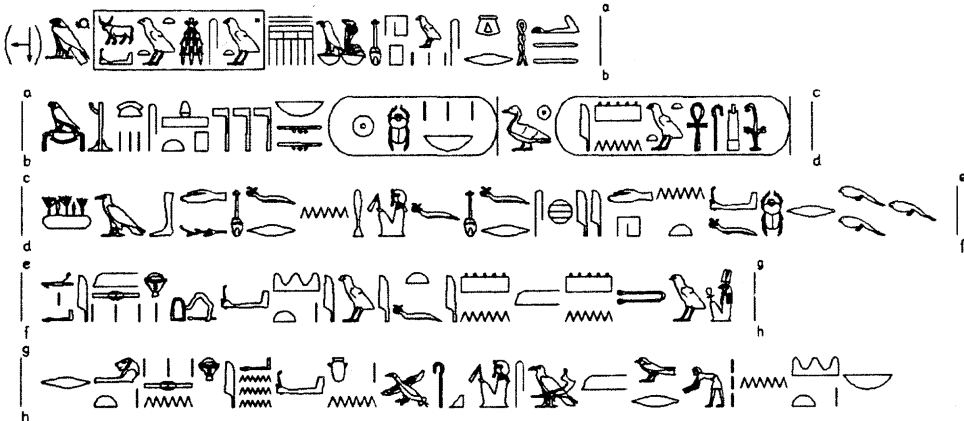

227a - Stab



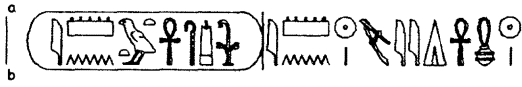

am oberen Ende (→)

227b - Stab

am oberen Knauf umlaufend:

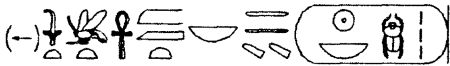

am unteren Knauf umlaufend:

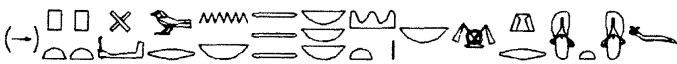

oben auf dem Stab: (→)

am Schaft:



(Unter dem Namen ist noch ein mit beginnender Name zu erkennen.)

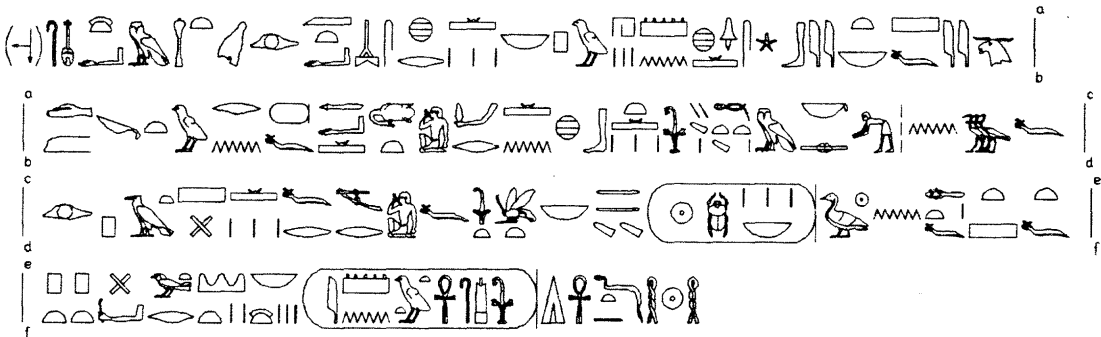

(Unter dem Namen ist noch

zu erkennen.)

227c - Stab

Oberes Band am Schaft:



Oberes Band am gebogenen Teil:

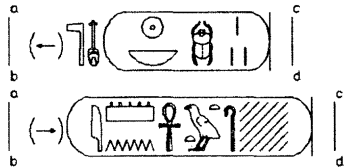

Unteres Band am gebogenen Teil:



am Schaft:

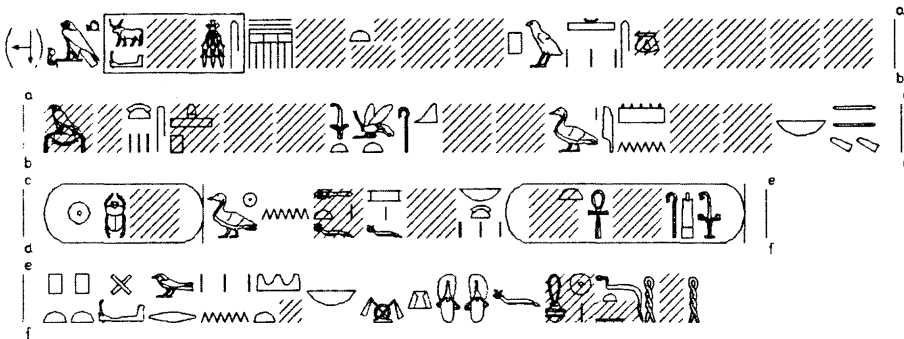

227d - Stab

am oberen Ende: (-) (circle with diagonal lines)

227e - Stab*

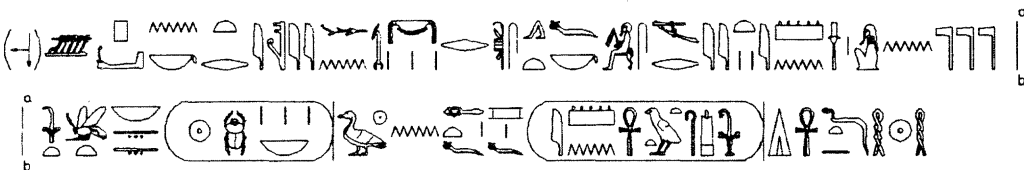

229 - Stab aus Rohr

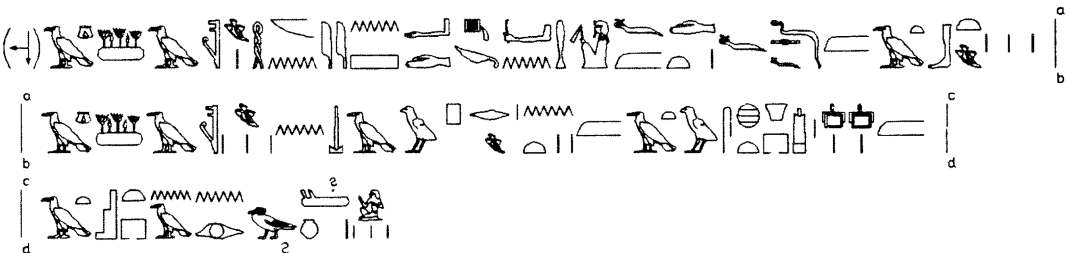

235a - Goldstatuette auf einem Stab

Textnachweis: London, Nr.22.

auf dem Gürtel der Statuette: (-) **237 - 2.Schrein (von außen).**

s. Piankoff, S.23 - 60

237a - Siegel, Typ "I" und "J"**238 - 3.Schrein (von außen).**

s. Piankoff, S.61 - 66

238a - Siegel, Typ "I" und "J"**239 - innerster Schrein.**

s. Piankoff, S.67 - 77

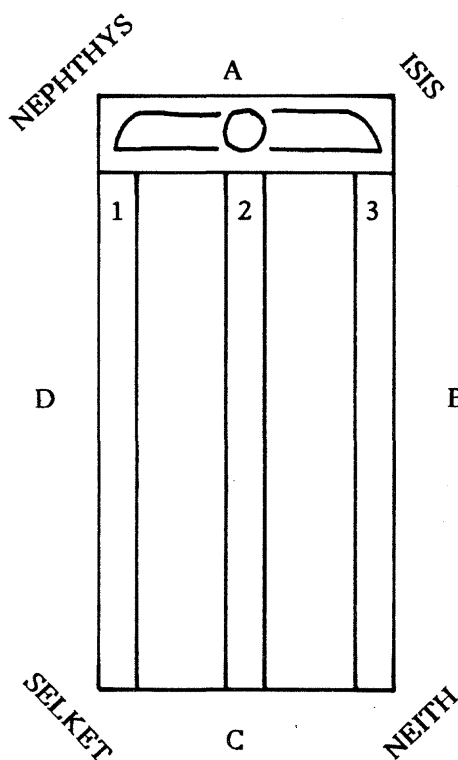
240 - SarkophagTextnachweis: Fox, Schatz, Abb.30; Fox, Treasure, Abb.26;
Edwards, S.117.

Sarkophag-Deckel

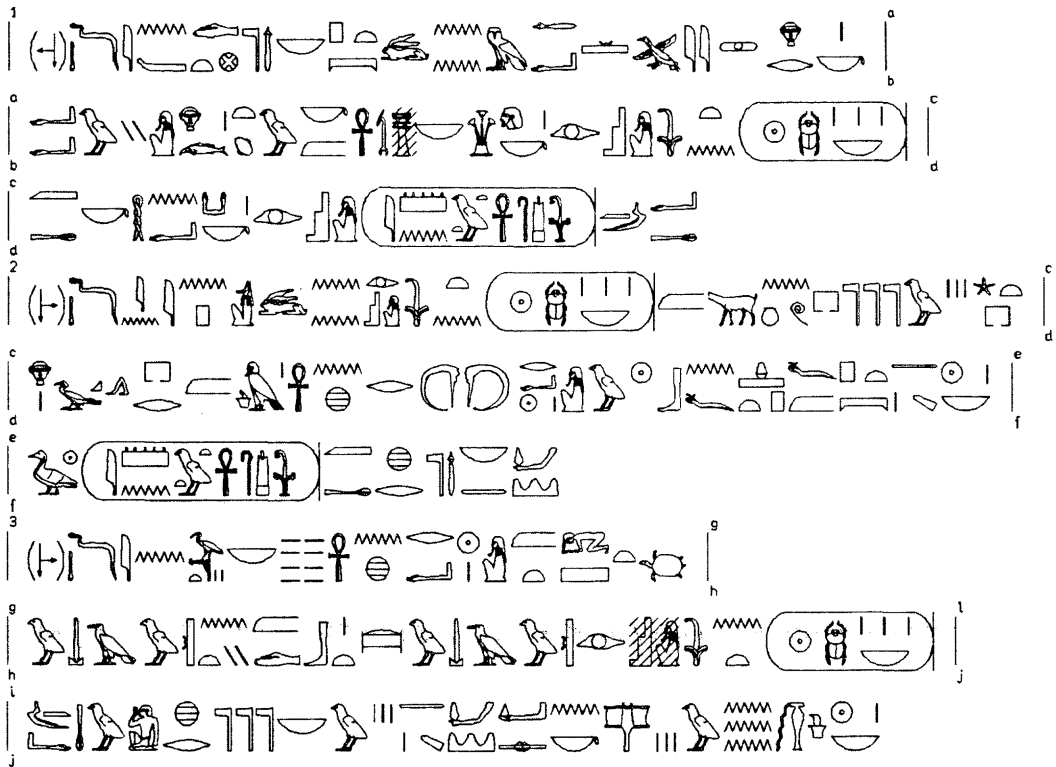

neben der geflügelten Sonnenscheibe: (-)  und (-) 

Sarkophag-Wanne:

Sarkophag, Isis-Nephthys-Seite (A)

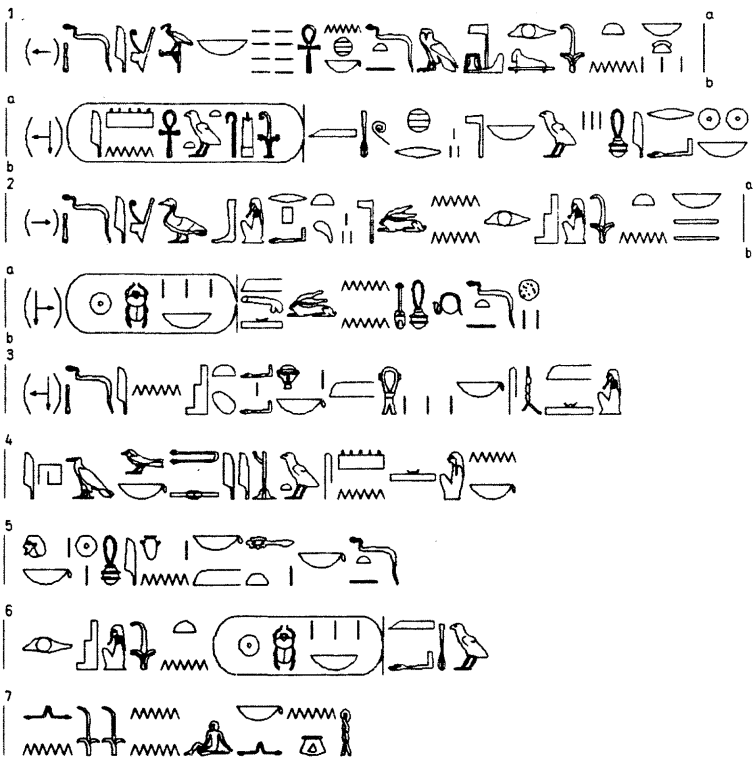

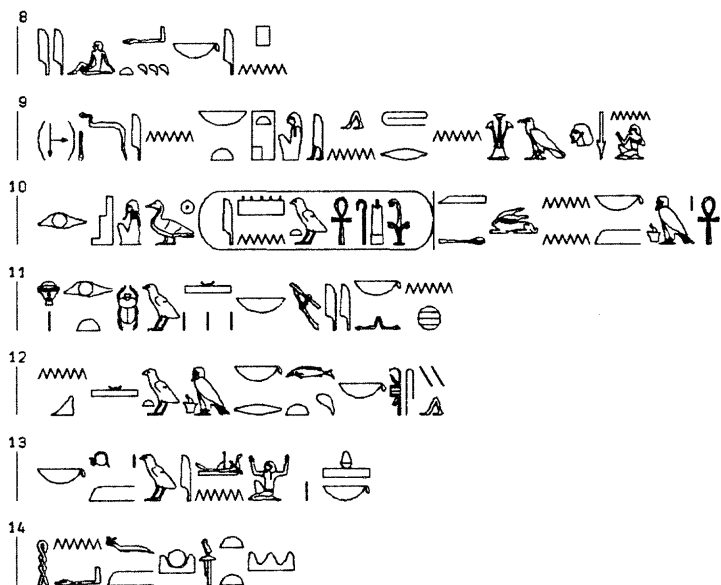

Sarkophag, Neith-Isis-Seite (B)

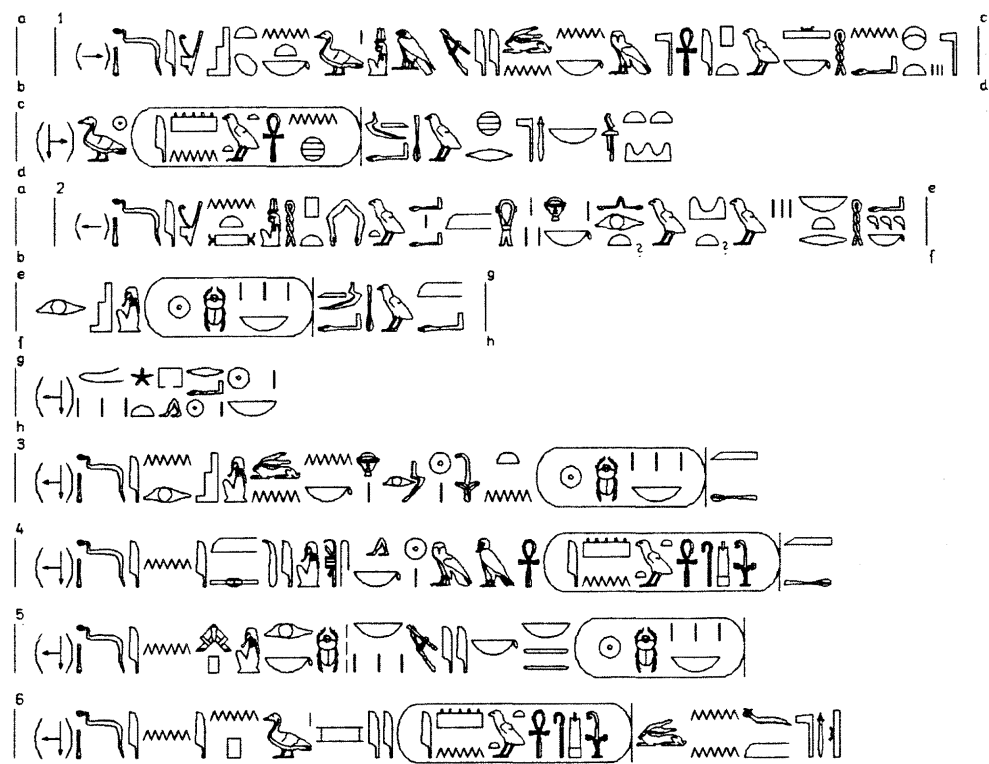

Sarkophag, Selket-Neith-Seite (C)

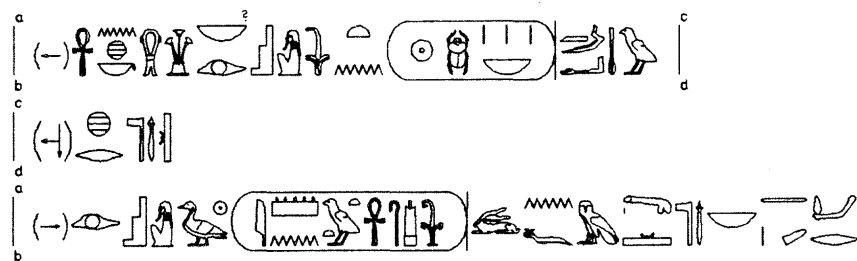

Sarkophag, Nephthys-Selket-Seite (D)

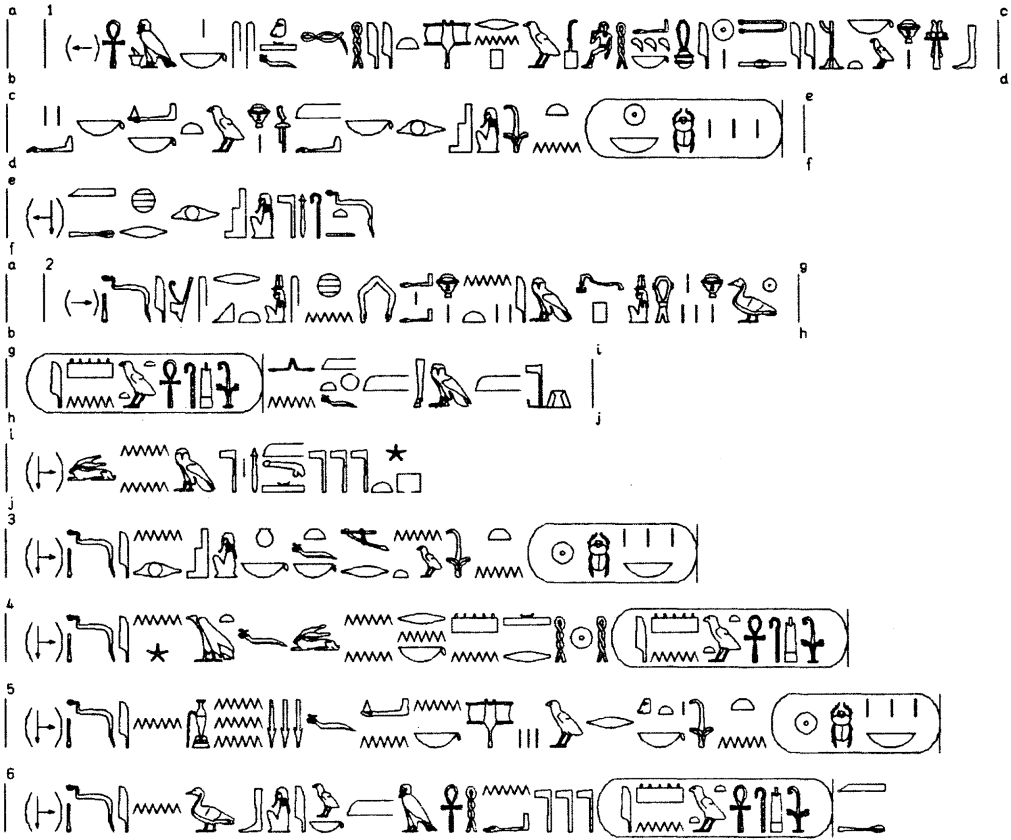

240bis - Salbgefäß in Kartuschenform

Textnachweis: Seton-Williams, Abb.99; Deutschland 80/81, Nr.23.

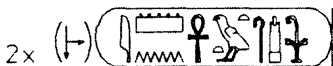

242 - Fächer mit Darstellung einer Straußenjagd

Textnachweis: Seton-Williams, Abb.79; Edwards, S.110-113; Paris, Nr.25; London, Nr23.

Vorderseite (bei der Jagd):



Rückseite (nach der Jagd):

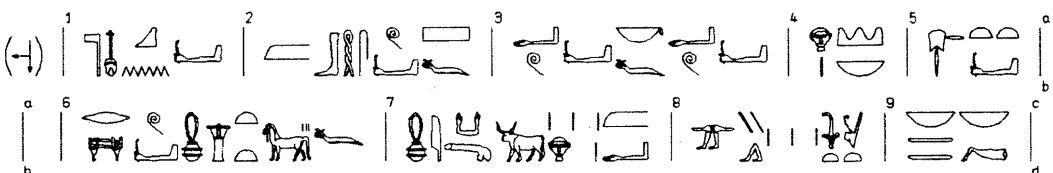

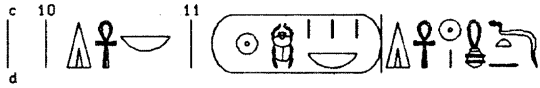

Text auf dem Stab:



245 - Fächer:

Textnachweis: Seton-Williams, Abb.147

zwei senkrechte Kartuschen:

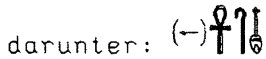
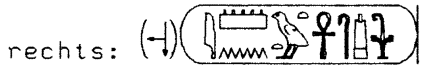
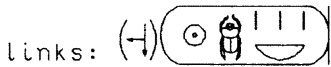

auf der Rückseite: gleiche Inschrift

253 - Äußerer Sarg (rechte Körperseite)

Textnachweis: Edwards, S.122f.

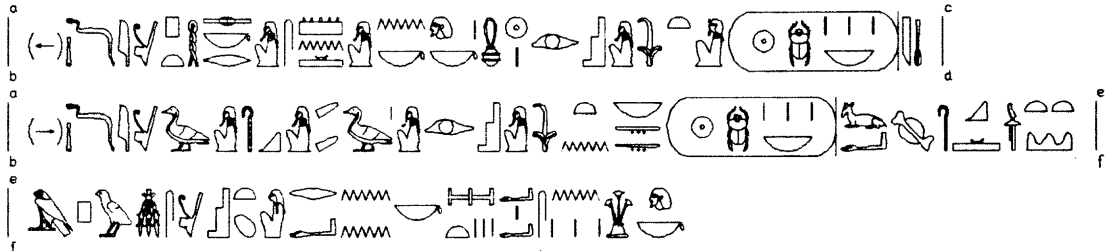

Äußerer Sarg (linke Körperseite)





254 - Mittlerer Sarg

Textnachweis: Edwards, S.124ff.; Seton-Williams, Abb.37;
 Lange-Hirmer, Taf.199; David, Abb.56; Riesterer, Abb.56;
 Le Musée du Caire, Abb.135-137, 139-140.

rechte Körperseite

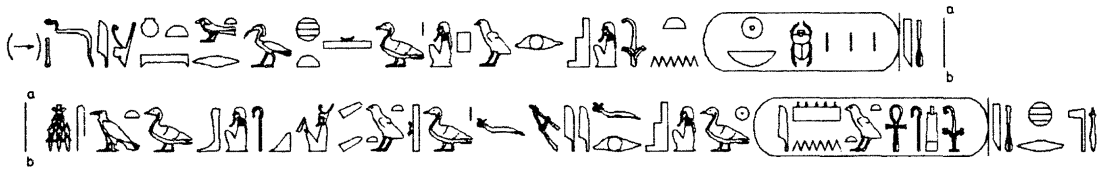

Mittlerer Sarg (linke Körperseite)

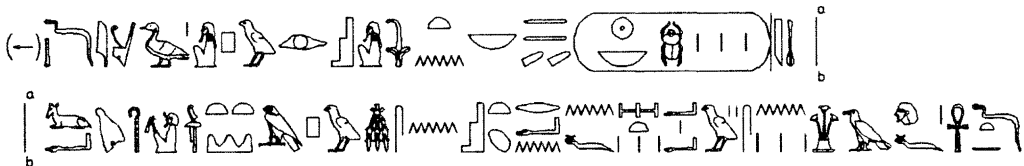

Mittlerer Sarg (Körper-Mitte)



Mittlerer Sarg, Sohle - oben

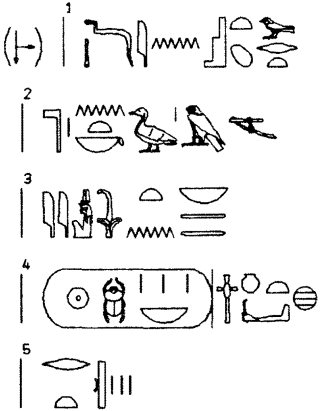



255 - Goldsarg (Innenseite)

Textnachweis: TutTS 5, Taf.13-15; Edwards, S.133.

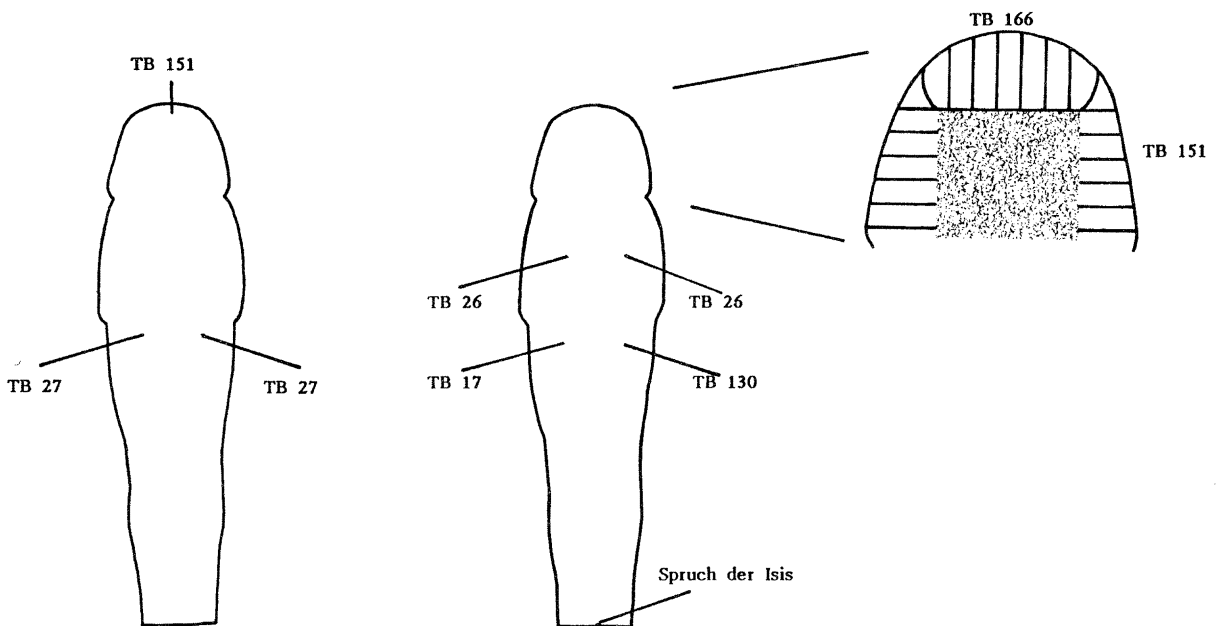

Sargoberteil - Verteilung der Inschriften

Sargunterteil - Verteilung der Inschriften

Im März 1987 wurde zur Textaufnahme für das vorliegende Corpus der Goldsarg des Tutanchamun geöffnet. Dabei wurden folgende Beobachtungen gemacht:

Sowohl der Deckel als auch das Unterteil des Sarges sind innen mit einer Nut-Darstellung und mehreren Inschriften verziert. Das Unterteil des Sarges ist, im Gegensatz zum Oberteil, noch recht stark von den Balsamierungsölen verschmutzt. Die Texte und Darstellungen sind unter dieser schwarzen Schicht aber sehr gut erhalten. In Details müssen die nachfolgenden Abschriften deshalb als unsicher gelten. Zumindest das Sargunterteil scheint aus zwei getrennt gearbeiteten "wannen"-artigen Teilen zu bestehen. Die innere "Wanne" wurde, nachdem sie mit den Texten und der Darstellung versehen war, in die äußere Wanne hineingesenkt und mit ihr verbunden. Wohl bei der Bestattung scheint die Goldmaske des Tutanchamun nicht in den Goldsarg gepaßt zu haben, denn man findet an der Stelle, wo sie in dem Goldsarg gelegen hat, eine Beschädigung der inneren Wanne. Es wurde hier aus dem Bereich, wo das Totenbuch-Kapitel 151 steht, ein etwa quadratisches Stück aus dem Goldblech herausgeschnitten. (Siehe

dazu die Skizze "Sargunterteil - Verteilung der Inschriften). Die
Schnittränder sind deutlich zu erkennen.

Sargunterteil, innen

Kopf, oben

Totenbuch 166

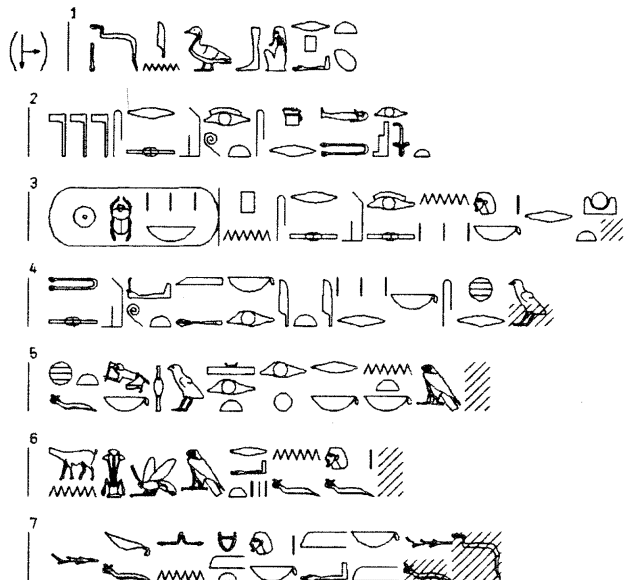

Sargunterteil, innen

Kopf, unten

Totenbuch 151

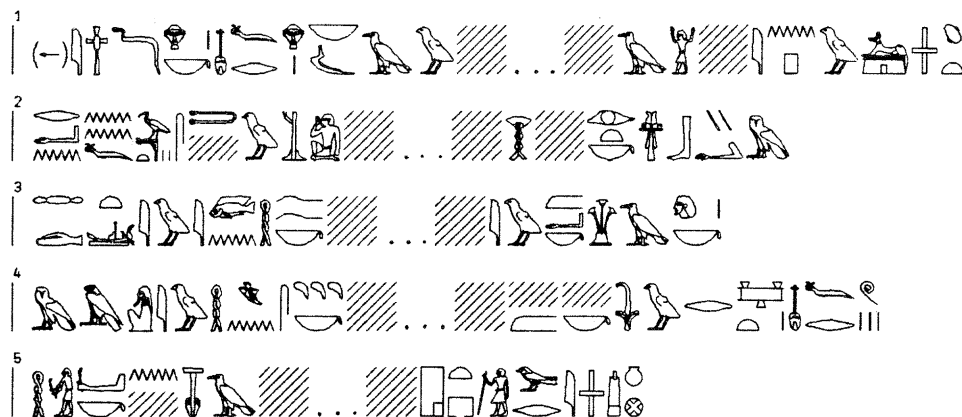

Sargunterteil, innen

über den Flügeln der Nut, rechts

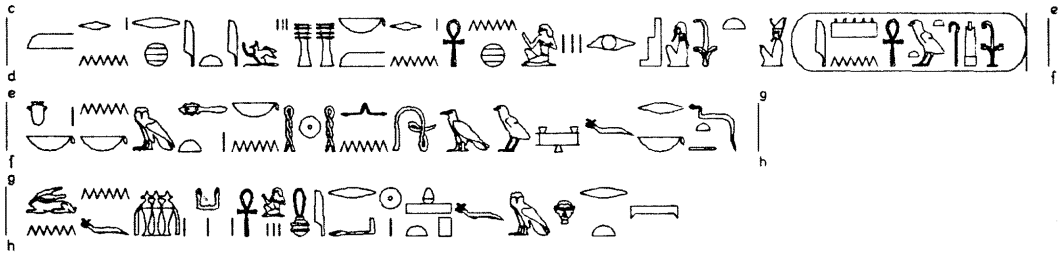

Mitte, rechte Körperseite

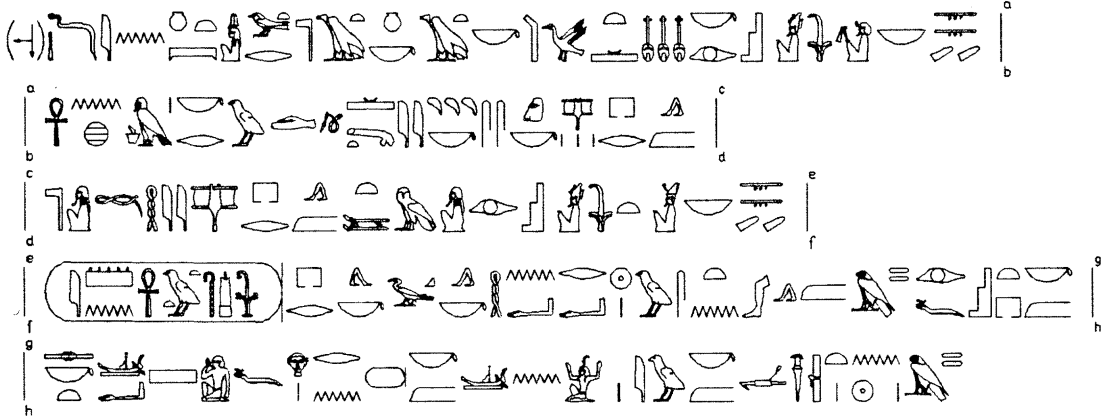

Seitenstreifen, rechte Körperseite

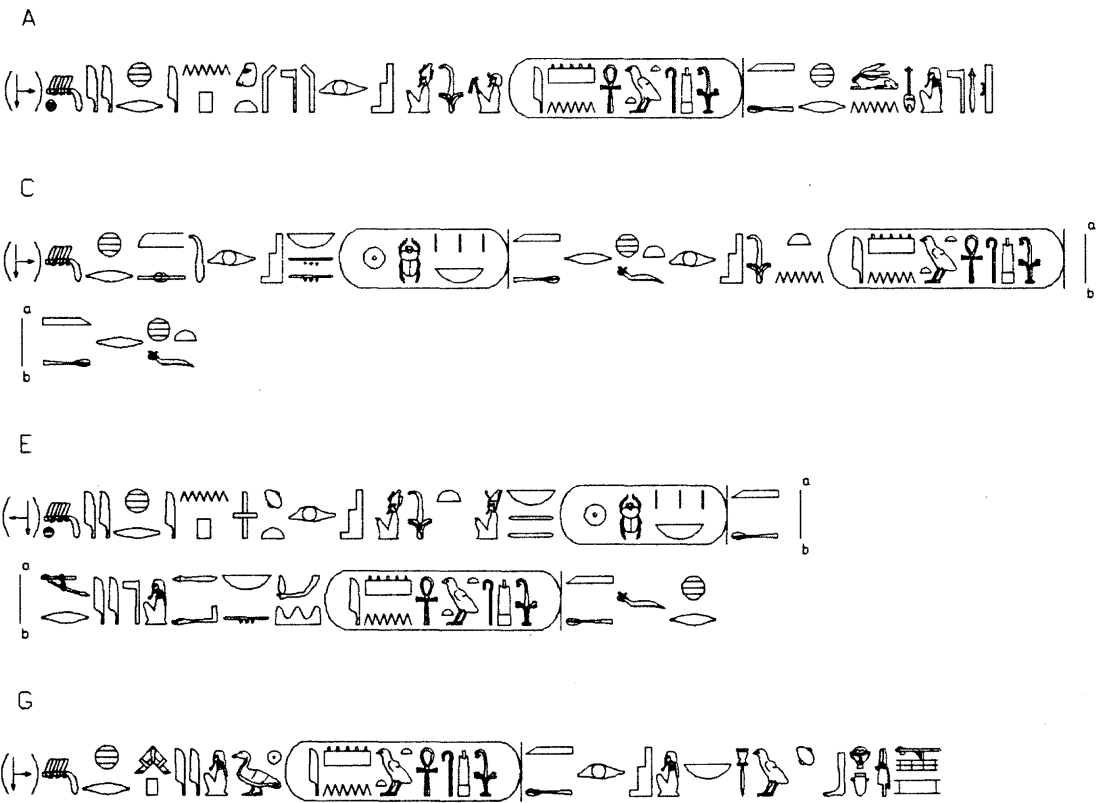

linke Körperseite

B

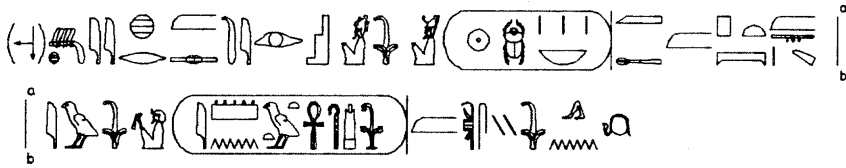

D

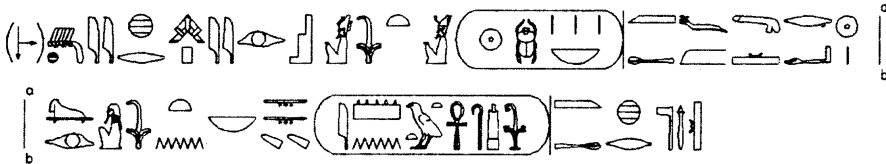

F

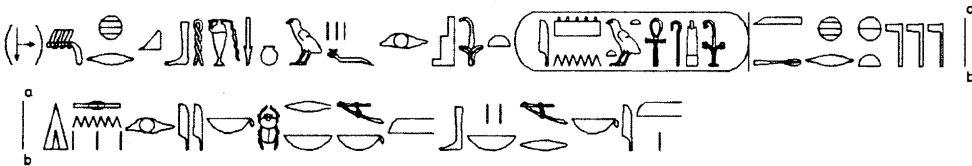

H

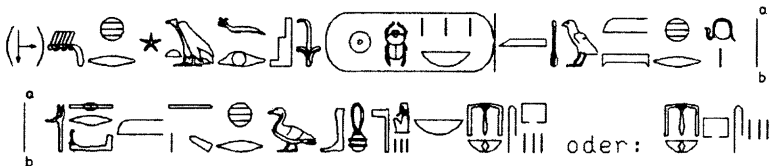

Einzelstücke:

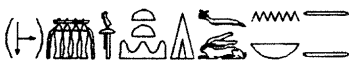
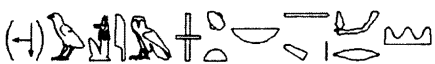

Rückseiten der Seitenstreifen, jeweils 3 Reihen links u.rechts
 (Teile der Seitenstreifen, wie sie heute in Kairo ausgestellt sind,
 dienten bei Auffindung der Mumie als Kettenglieder am Skarabäus
 256a, dort sind heute auch noch zugehörige Teile)

1. Reihe (H)



2. Reihe (H)



3. Reihe (H)

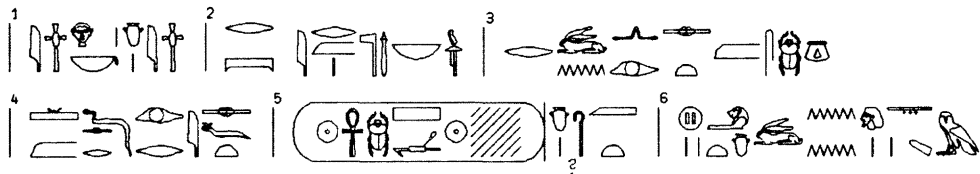

andere Seite

1. Reihe (H)

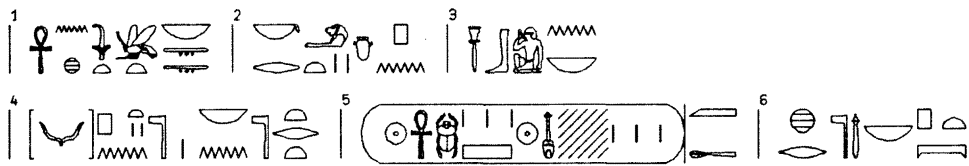

2. Reihe (H)

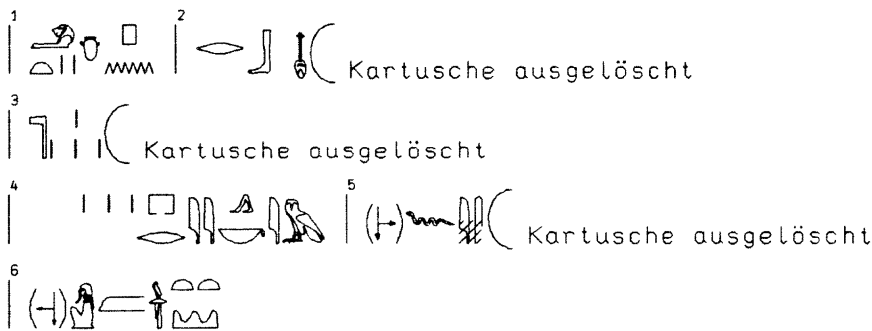

3. Reihe (H)



4. Reihe (H)



nach Abschr. Oxford noch ein Stück:





nach Abschr. Oxford noch ein Stück:



evtl. auch noch das Stück: (H)

256l - Gürtel



256n - Goldreifen

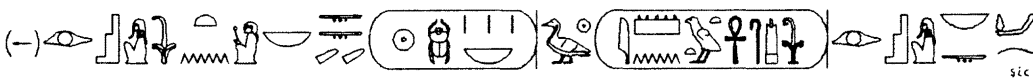

256p - goldener Halskragen in Form eines Falken

hieratischer Vermerk an den Federn des rechten Fußes (heute ver-

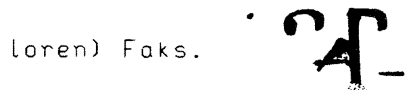

256q - Skarabäus mit Benu-Vogel, Totenbuch 29B

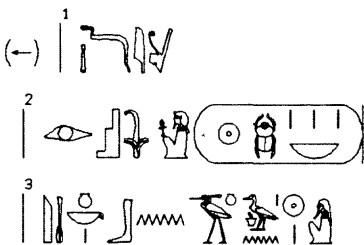

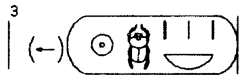
**256oo - Armband**

Textnachweis: USA, Nr.21

**256qq - Armband**

Textnachweis: Séton-Williams, Abb.103.

außen und innen jeweils zwei Kartuschen:

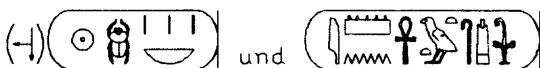



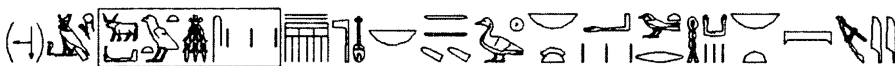

Inscript am Verschuß:

**256ss - Armband mit Skarab.**



(-)||| flankiert von:  (das Zeichen  hat Flügel)

256vv - Fingerringe

Nr.1: (-)||| flankiert von: 

Nr.2 (-)|¹||||²||||

Nr.5 genau wie Nr.2

Nr.7  =  vor thronendem Re-Harachte, am Ring kleine Kartu-

sche v. Tutanchamun, darüber: || das Zeichen  hat Flügel.

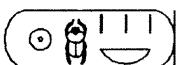
256aaa - Armband mit Udjat-Auge**256ccc - Ring. König opfert Maat, am Ring:**

256000 - Pektoral

Textnachweis: Seton-Williams, Abb.97

auf Gegengewicht:

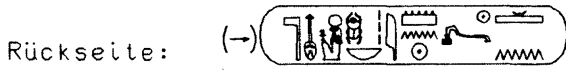
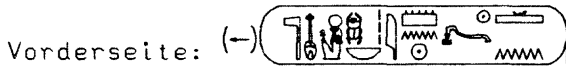

256ppp - Pektoral, Geier

Textnachweis: Edwards, S.151; USA, Nr.24.



256qqq - Pektoral

auf Gegengewicht:



256rrr - Halsschmuck mit Udjat-Auge

Textnachweis: Seton-Williams, Abb.96; Vilimkova, Nr.40.

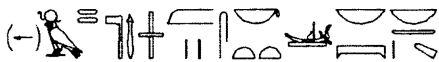

256uuu - Pektoral

auf Gegengewicht:

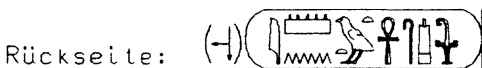
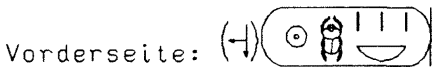

256.4t - Kappe mit Perlenstickerei

Mehrere Kartuschen:



257 - magische Figur (Osiris)

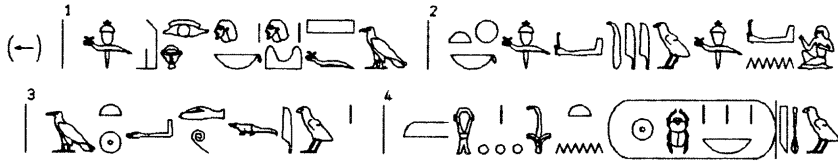

259 - magische Figur (Uschebti)



260 - magische Figur (Djed)

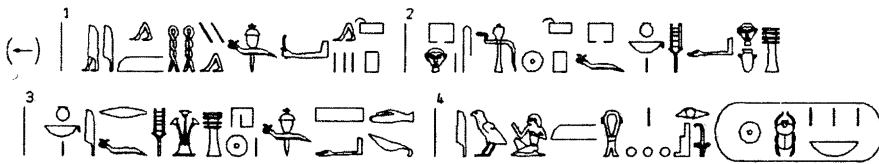

261 - Anubis-Schrein

Textnachweis: Seton-Williams, Abb.50; Lange-Hirmer, Taf.XXXII;
 Lange, Pyramiden, Abb.22; Fox, Schatz, Abb.46;
 Fox, Treasure, Abb.39; Riesterer, Abb.14.

Vorderseite

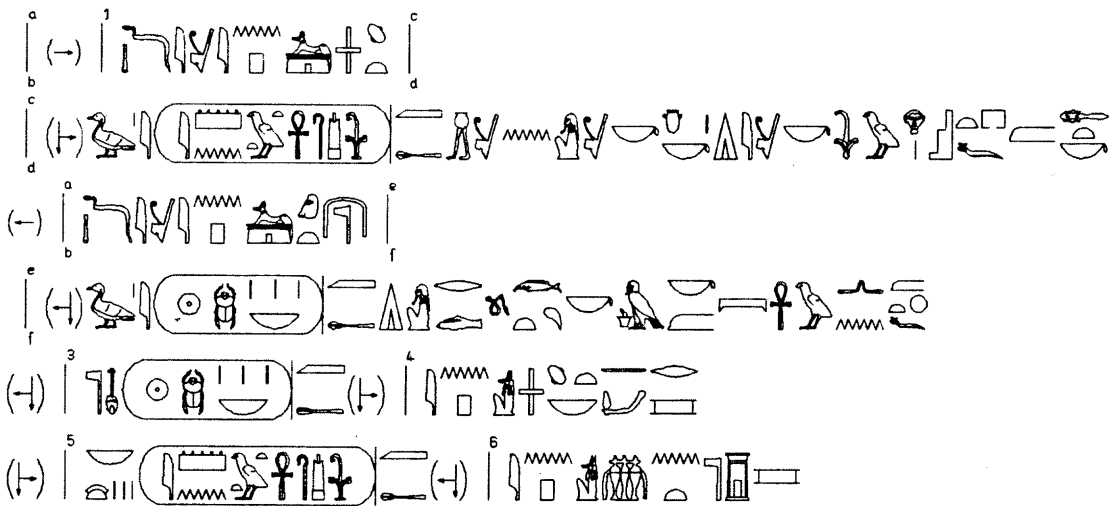

links

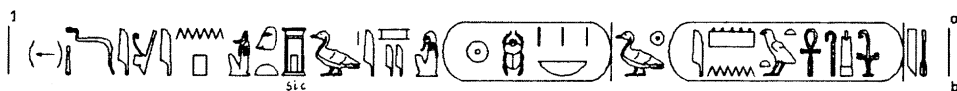

über dem Skarabäus:



Auf der Rückseite des Skarabäus (Totenbuch 27):

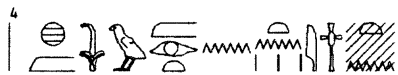
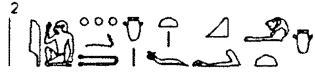

7
| nicht identifizierbare Zeichenreste

261m - Pektoral

Textnachweis: Seton-Williams, Abb.88.

Vorderseite:

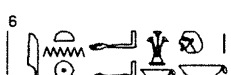
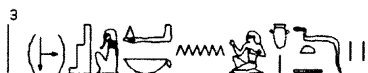
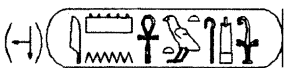

Rückseite:

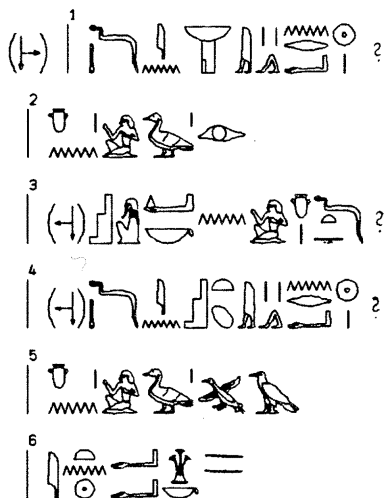

dazu gehört noch der Skarabäus 269a (4) (jetzt zusammengefügt)

mit Totenbuch 30B:

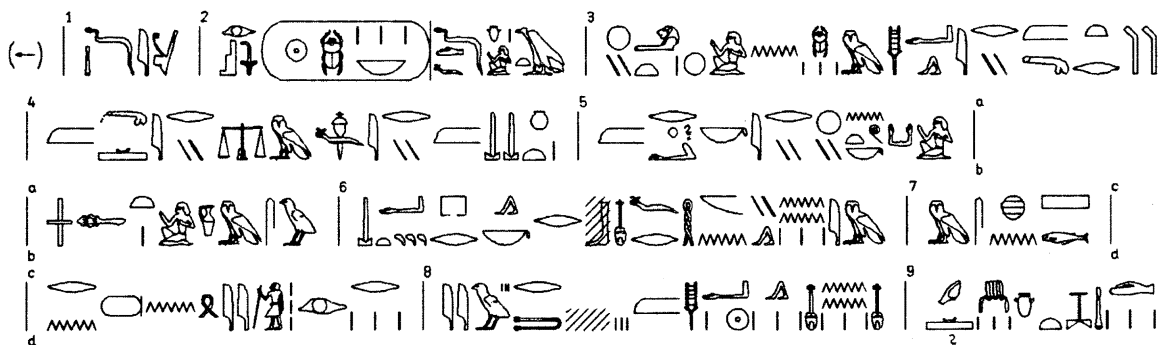

261n - Pektoral

Textnachweis: Vilimkova, Nr.49.

Vorderseite:

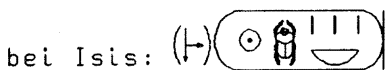
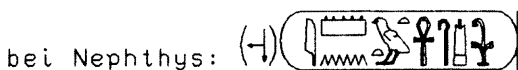

Rückseite (Totenbuch 26):

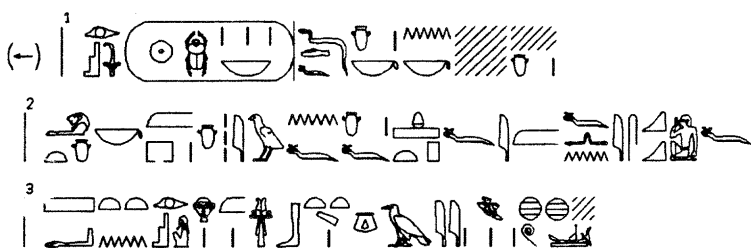

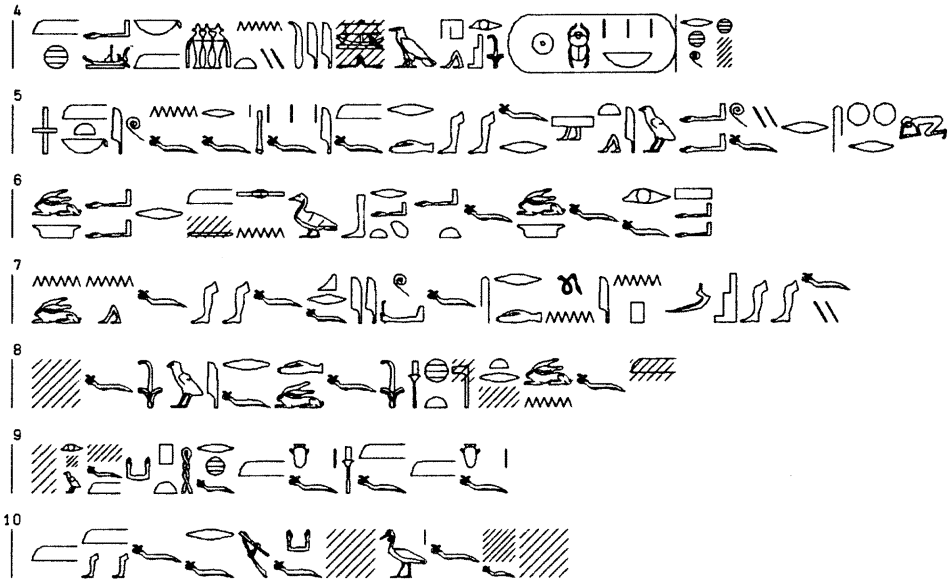

der Text ist von zwei Kartuschen  flankiert.

261o - Pektoral

Textnachweis: Aldred, Nr.96.

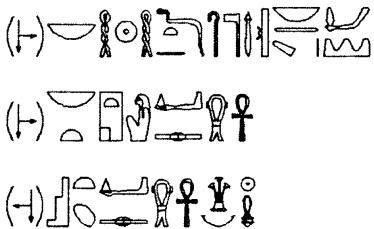

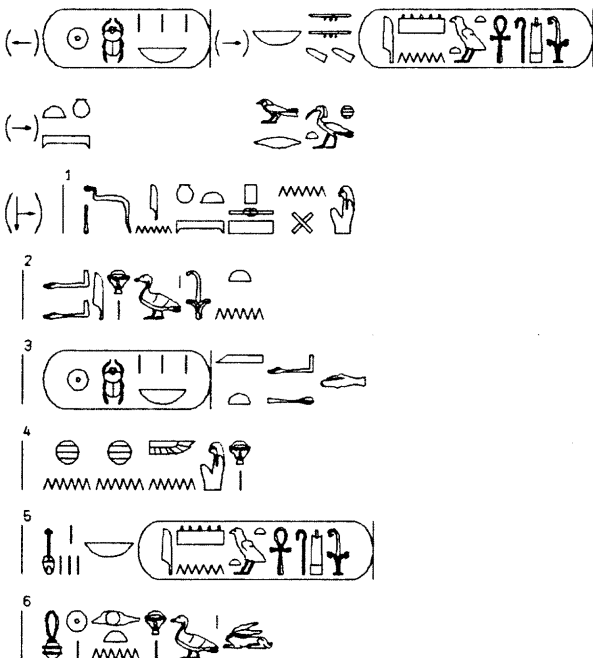

261p (1) - Pektoral

Textnachweis: Aldred, Nr.97.

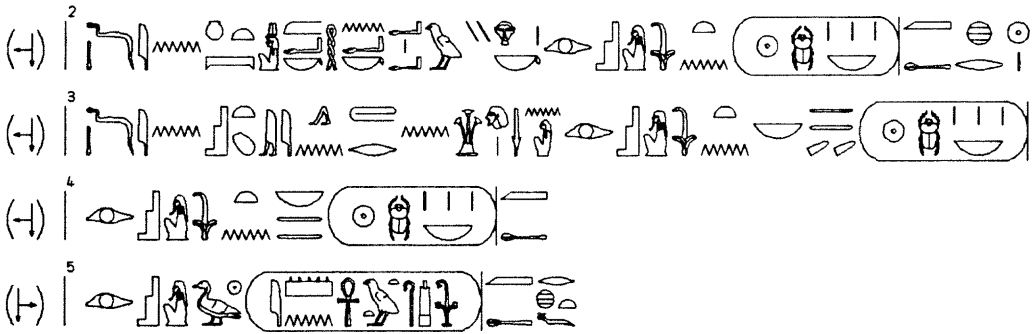



Markierungen, Vorderseite A u. B oben jeweils 
 ebenso auf dem Querbalken zwischen A u. B
 Markierungen, Rückseite E u. F oben jeweils 
 ebenso auf dem Querbalken zwischen E u. F

266a - Kanopenschrein, Holz

Dach*:

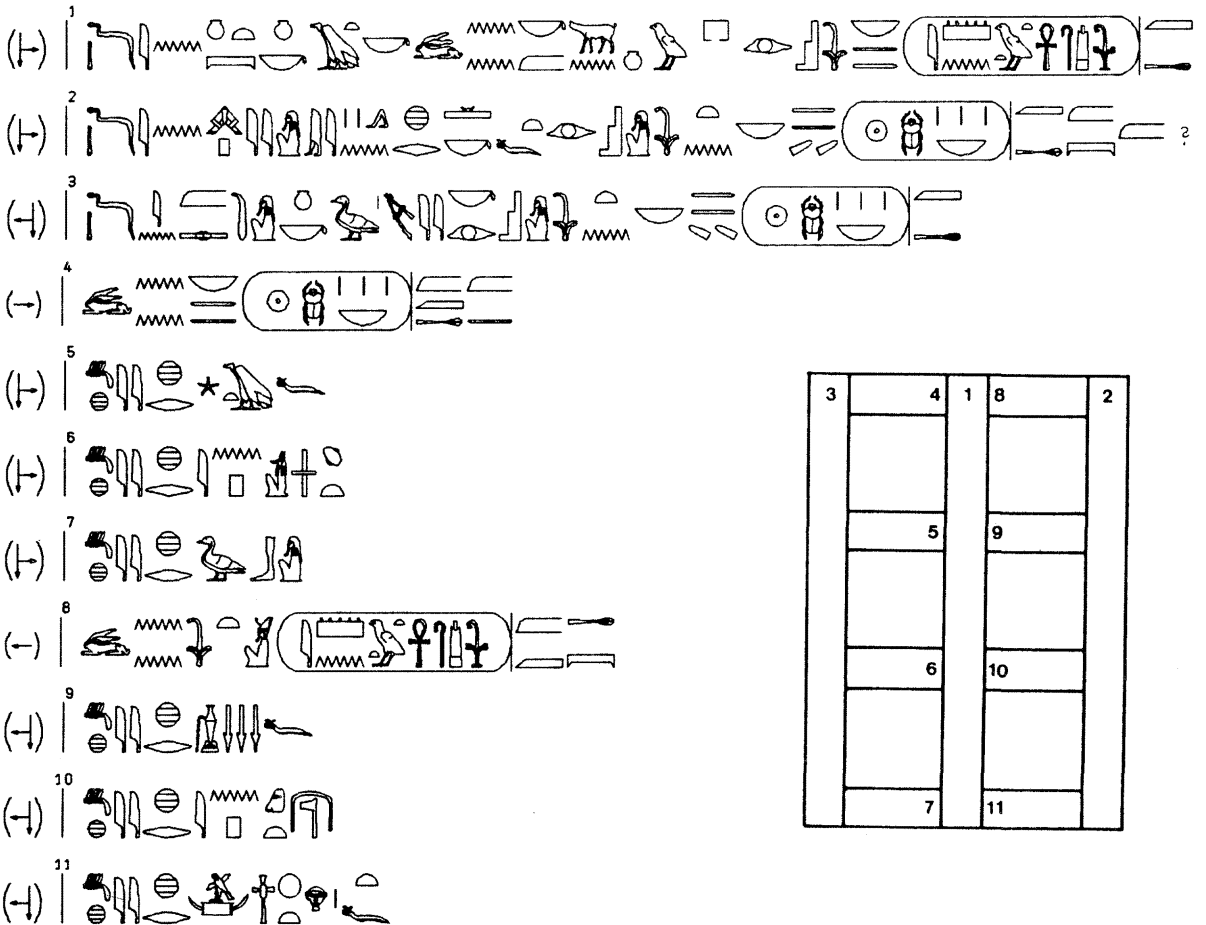



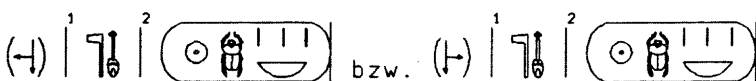

auf den beiden Seitenflächen des "Buckeldaches" vor den Uräen:







Markierungen:







Vorderseite:

in der Hohlkehle links: (-)  Mitte: (-) 
 darüber (auf dem Deckel): links:  Mitte: 





linke Seite:

in der Hohlkehle links: 
 auf dem Deckel links: 
 in der Hohlkehle rechts: 
 auf dem Deckel rechts: 

Rückseite:

in der Hohlkehle links: (-) 
 auf dem Deckel links: (-) 
 auf dem Deckel Mitte: 
 in der Hohlkehle rechts: 
 auf dem Deckel rechts:  oder 

rechte Seite:

in der Hohlkehle links: 
 auf dem Deckel links: 
 auf dem Deckel Mitte: (-) 
 in der Hohlkehle rechts: (-) 
 auf dem Deckel rechts: (-) 

266a - Kanopenschrein, Isis-Figur

auf dem Rücken der Isis: 

266b - Alabasterschrein

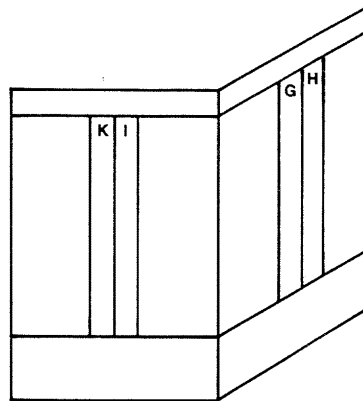
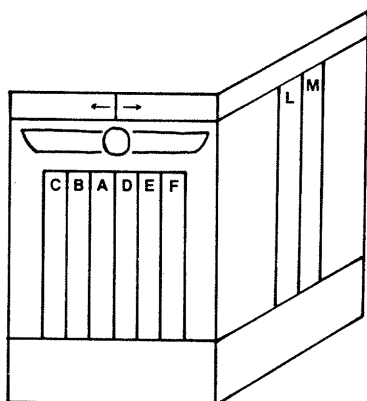

Textnachweis: Seton-Williams, Abb.52; Lange, Pyramiden, Taf.39;
 Lange-Hirmer, Taf.198; Edwards, S.162.



Deckel

Text auf der Oberseite:







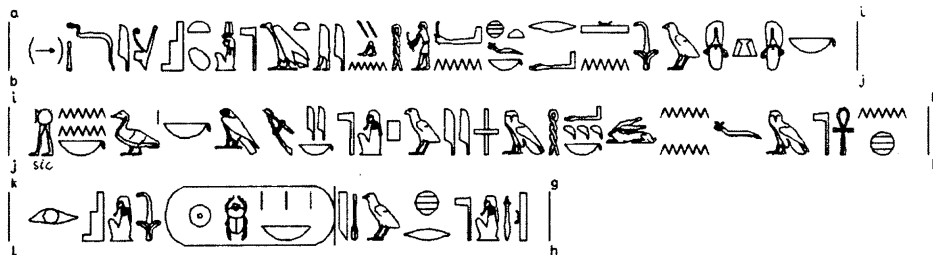
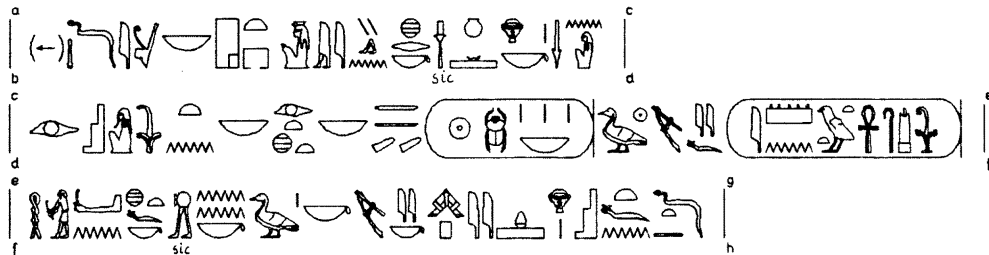

(der Name  ist innerhalb der Kartusche von  und  flankiert)

umlaufendes Band an der Seite des Deckels:

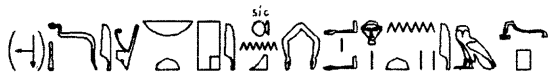

Kasten

vorn:

- A: 
- B: 
- C: 
- D: 
- E: 
- F: 

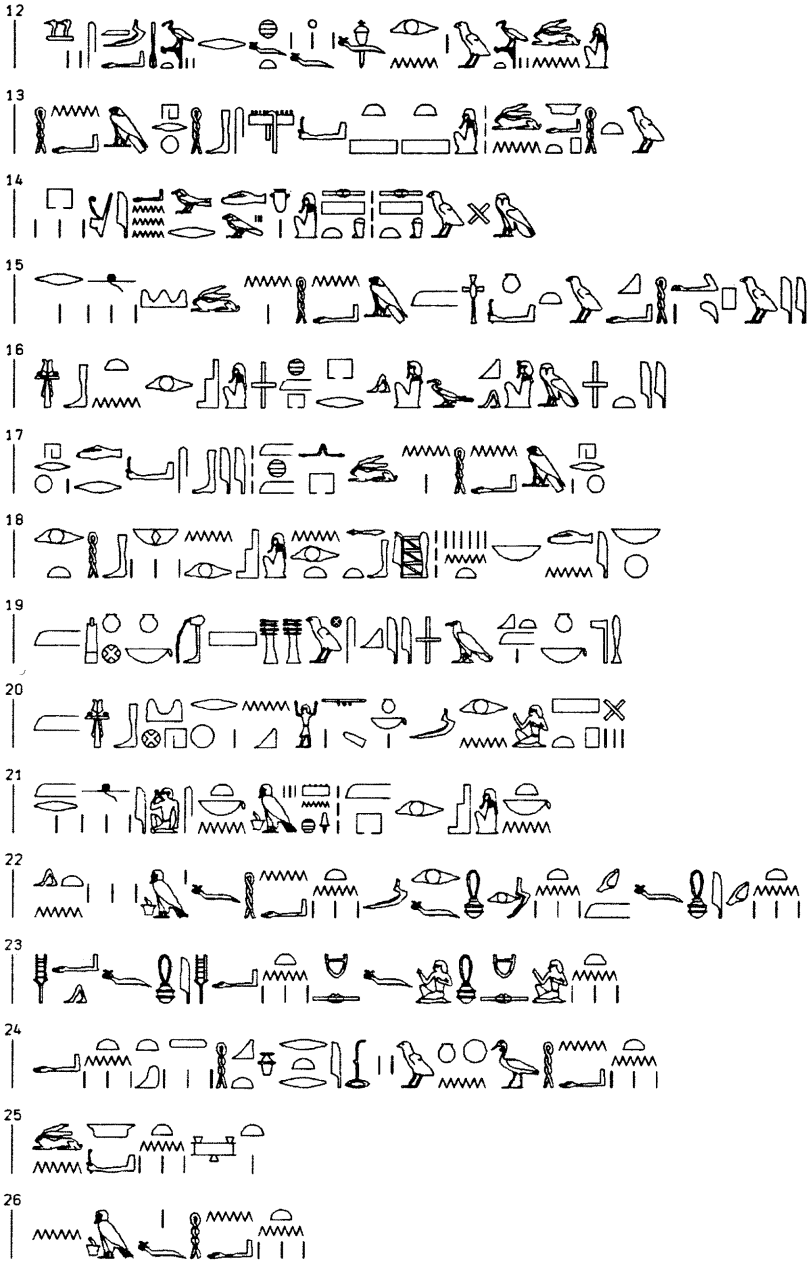

266g - Kanopensarg Neith

Textnachweis: ASAE 40, 1940, Taf.23.

Kanopensarg Neith. Außen, vorn



Kanopensarg Neith. Innen, Vorderseite

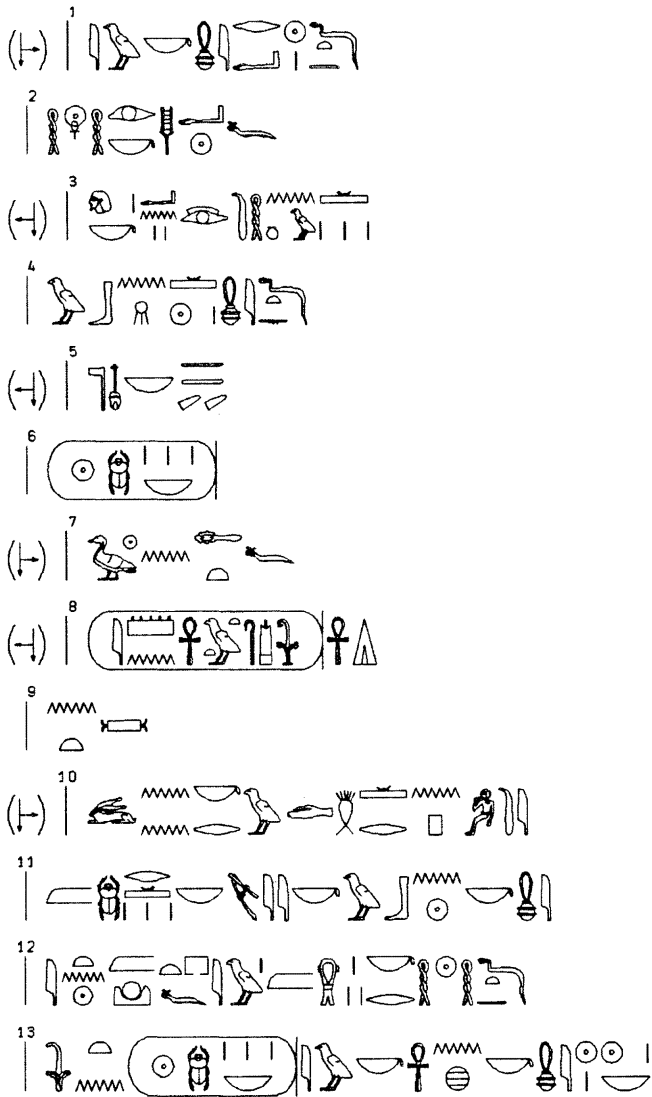

Kanopensarg Neith. Innen, Rückseite

Totenbuch 130



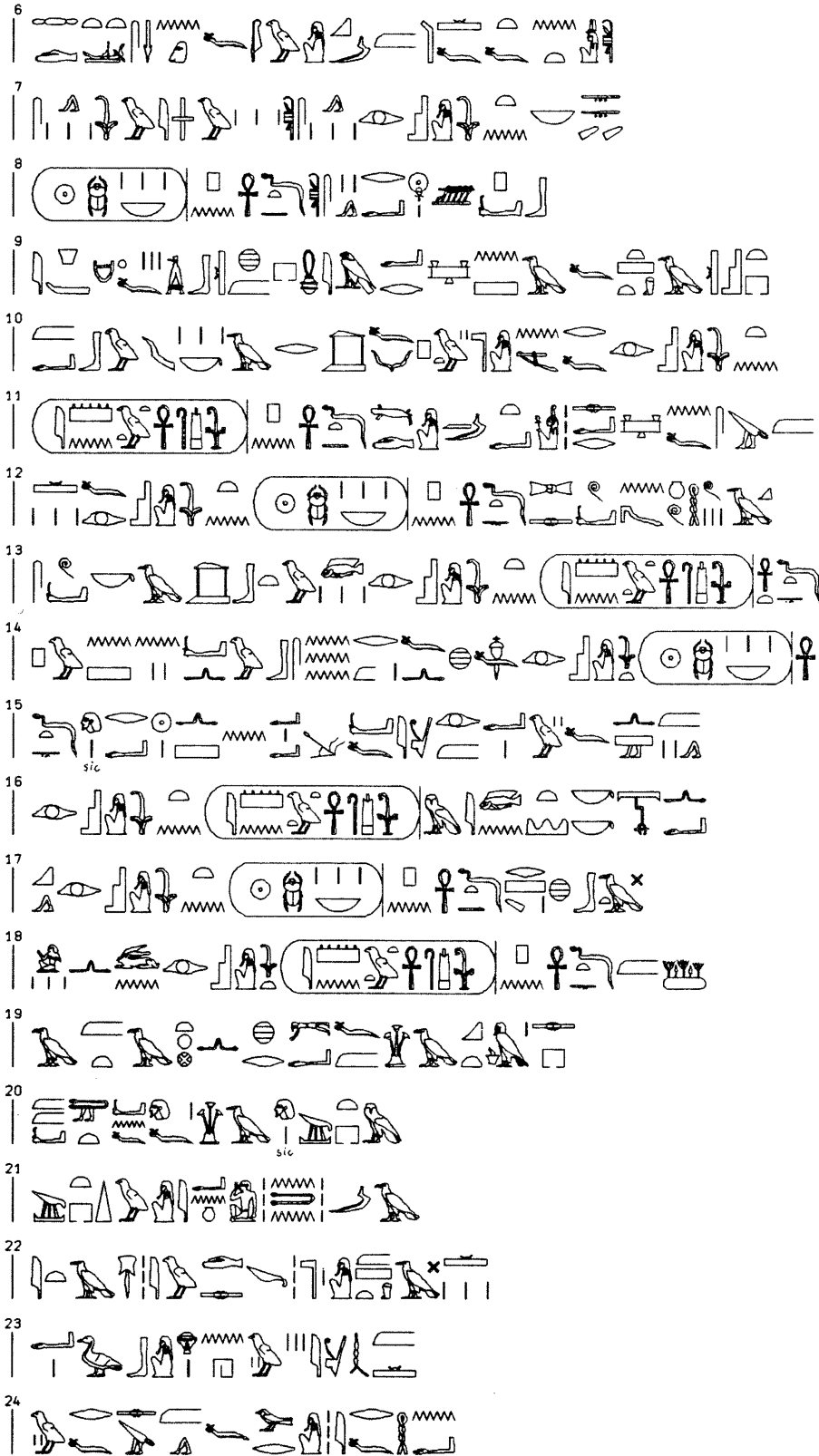

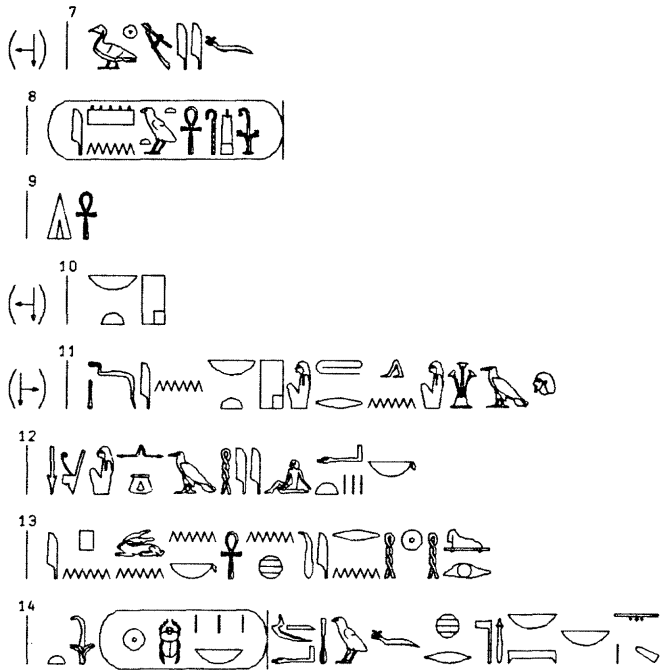

Kanopensarg Nephthys. Innenseite hinten

Totenbuch 134

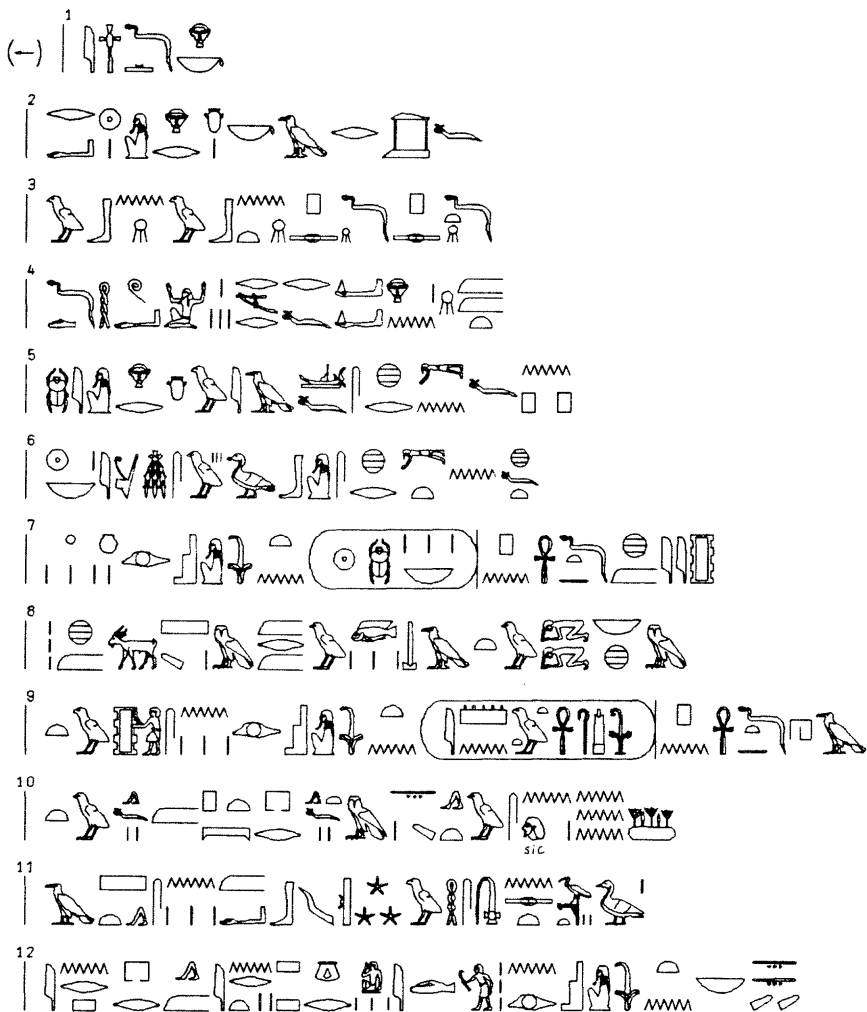



266g - Kanopensarg Selket

Textnachweis: Edwards, S.164f.; Deutschland 80/81, Nr.45;
USA, Nr.45.

Kanopensarg Selket. Außenseite vorn

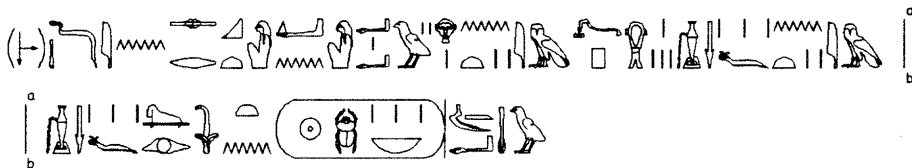

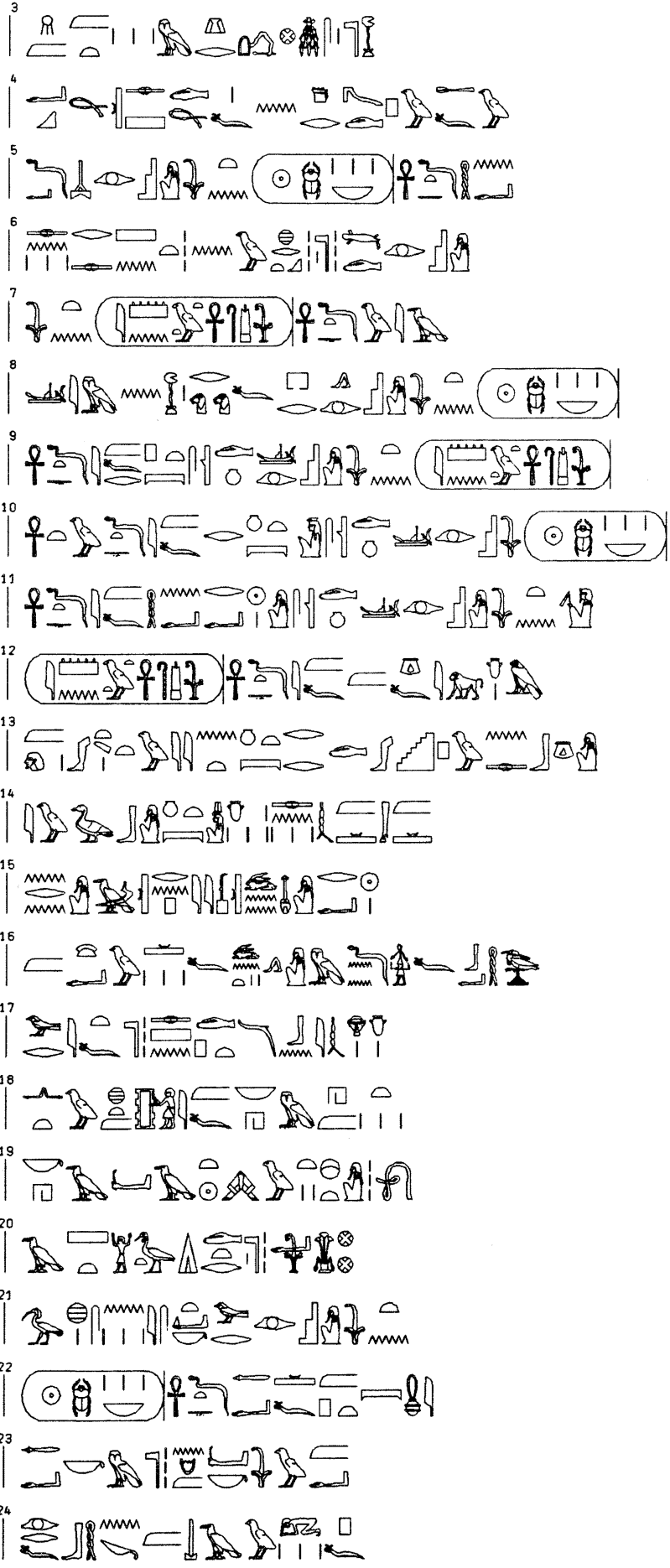

Nephtys: Zeile 26

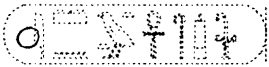

Selket: Zeile 5

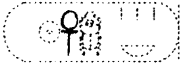

Selket: Zeile 7

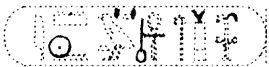

Selket: Zeile 8

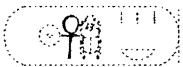

Selket: Zeile 9

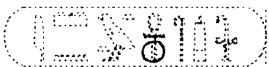

Selket: Zeile 10

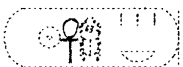

Selket: Zeile 22

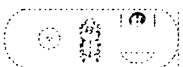

267 - Kasten mit hieratischer Inschrift, TutTS 2, Nr.52

267b - Gegengewicht

Textnachweis: Aldred, Nr.107 (rechts).



267k - Pektoral

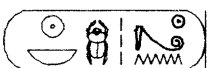

267q - Pektoral

Textnachweis: Aldred, Nr.99



Seiten des Stiels

links: 

rechts: 

An den drei Enden (Vorder- u. Rückseite) jeweils 2 Kartuschen:





269d - Heka-Szepter

oberes Ende: 

unteres Ende: 

269f - Flagellum

Textnachweis: London, Nr.44 (Detail links).

am unteren Ende zwei Kartuschen:





269g - Armband

Textnachweis: Aldred, Nr.109 (unten); Fox, Schatz, Abb.56a;
Fox, Treasure, Abb.48a; Vilimkova, Nr.55.

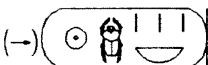
Vorderseite: 

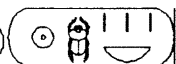
Rückseite: 

269h - Heka-Szepter

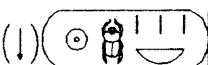
oberes Ende: 

unteres Ende: 

269i und j, siehe 267q

271 - Truhe

Textnachweis: Seton-Williams, Abb.142; Edwards, S.178f.;
Fox, Schatz, Abb.58; Fox, Treasure, Abb.50.

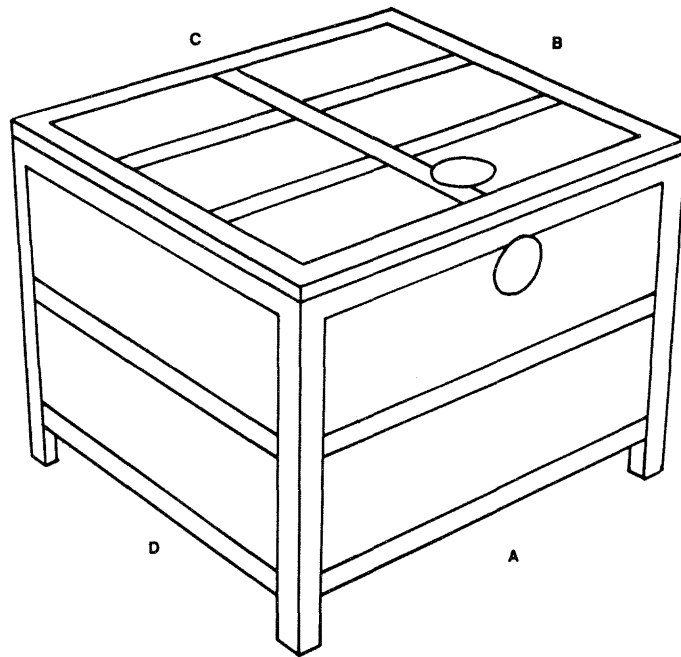

Siegel, Typ "M" und "N"

Seite A, linke Hälfte:

oben:

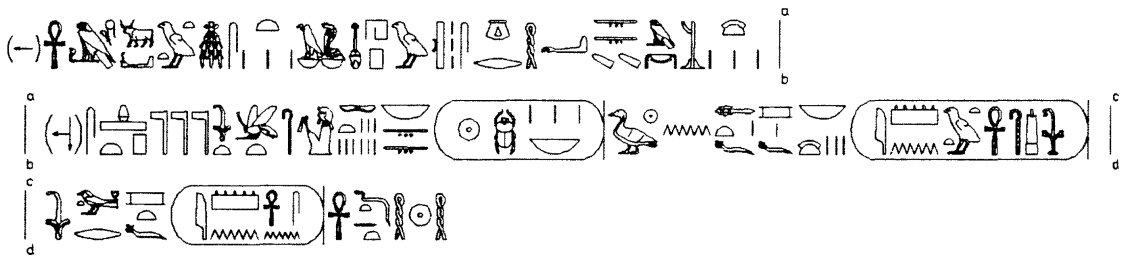

Mitte:



unten:



Seite A, rechte Hälfte:

oben:

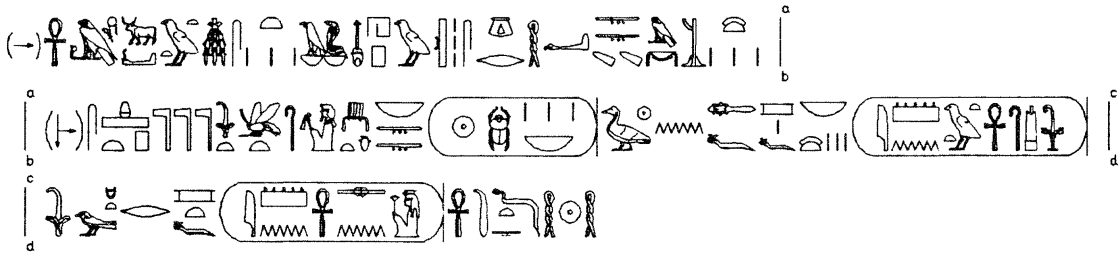

Mitte:



unten:



Seite B:

oben:

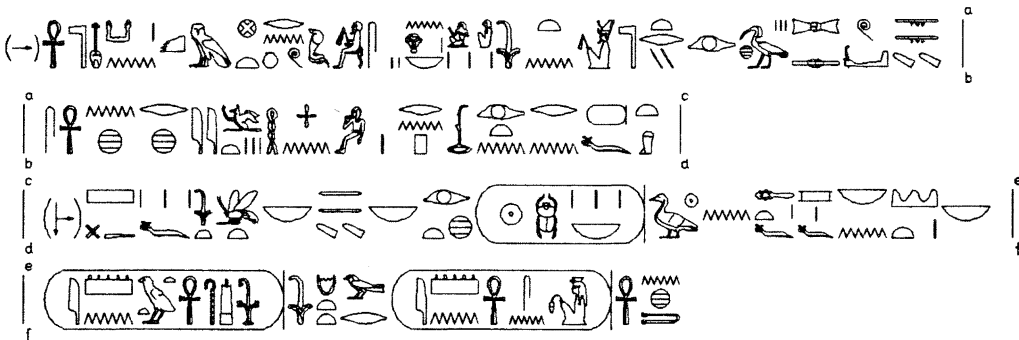

linke Zeile:

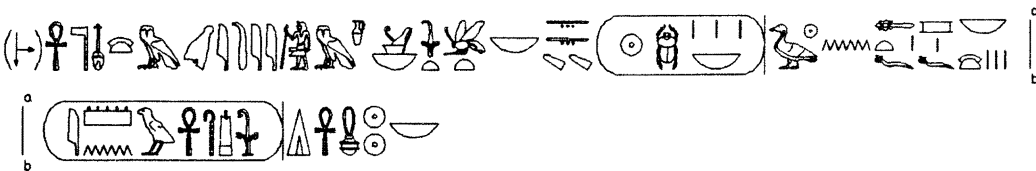

Mitte:

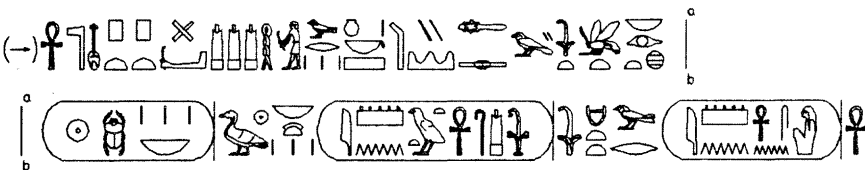

unten:

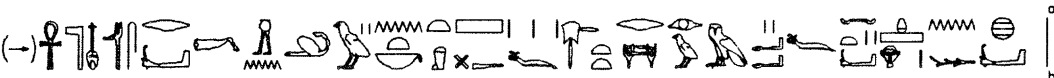



Seite C, linke Hälfte:

oben:

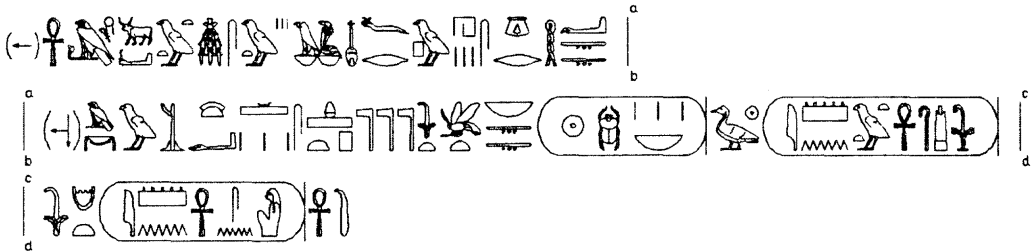

Mitte:

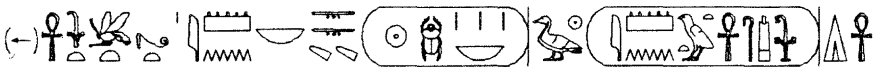

unten:



Seite C, rechte Hälfte:

oben:

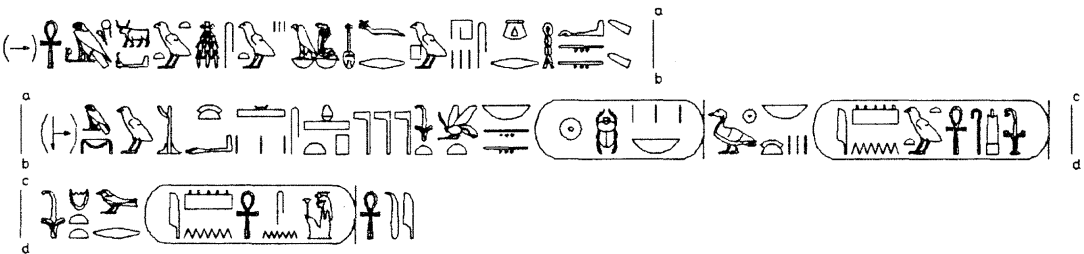

Mitte:



unten:



Seite D:

oben:



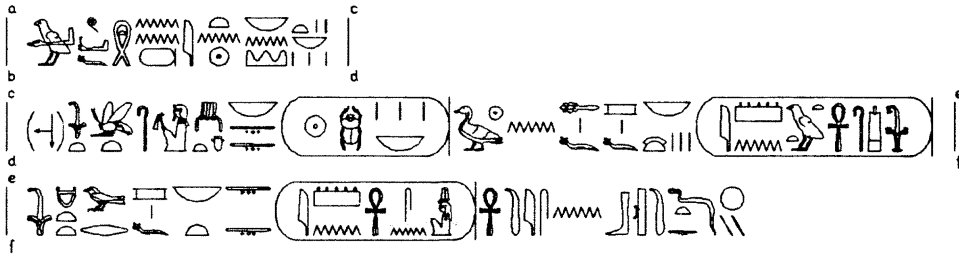

rechte Zeile:

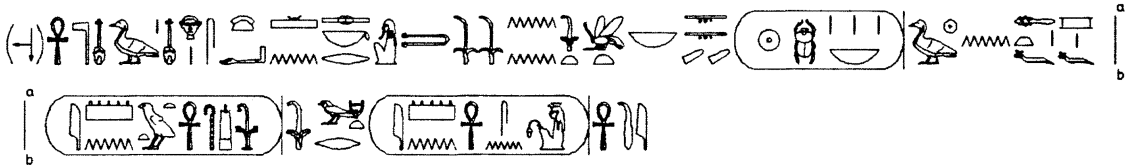

Mitte:



unten:



Deckel:

Mittelzeile:



linke Seite:

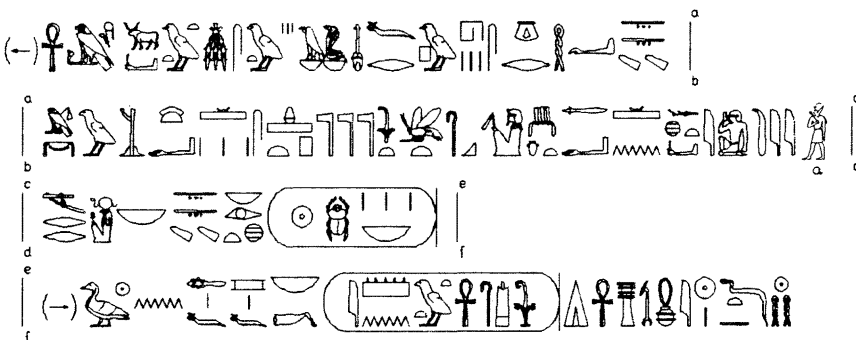

Mitte oben:



Mitte unten:



rechte Seite

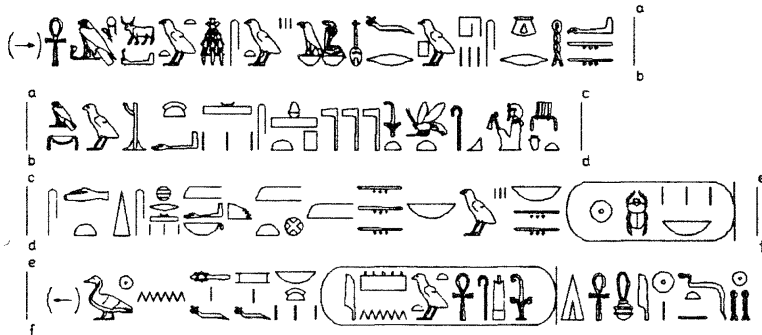

Mitte oben:



Mitte unten:



271a - Schilfkorb

Seite

vor Sachmet (Schriftzeichen undeutlich):

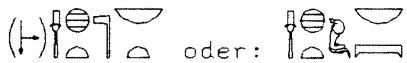

vor dem König:

vor Ptah:

Zeile 3 u. 4 evtl.:

Deckel: vor dem König:

vor Amun: Vor Horus

271e (1) - Schreibbinsenbehälter

Textnachweis: Fox, Schatz, Abb.47c; Fox, Treasure, Abb.40c.

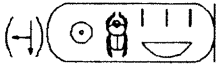

271e (2) - Palette

Textnachweis: Fox, Schatz, Abb.47d; Fox, Treasure, Abb.40c.

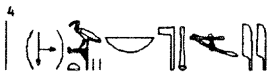
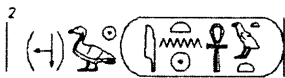
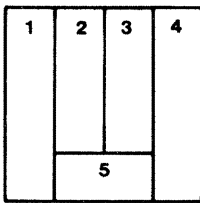

271g - Papyrusglätter

Textnachweis: Seton-Williams, Abb.150; Fox, Schatz, Abb.47b;
Fox, Treasure, Abb.40b; Deutschland 80/81, Nr.10.

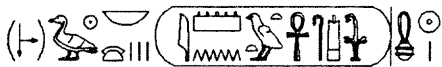

272 - Holzkasten

Hieratische Inschrift TutTS 2, Nr 54

Siegel, Typ "M" und "N"

272a - Fächer

Textnachweis: Seton-Williams, Abb.146; Riesterer, Abb.27.

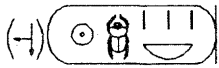

273 - Boot*

evtl. Inschrift am Heck

275b - Königsfigur*



275d - Königsfigur



276 - Bootsmodell



auf der anderen Bootsseite gleicher Text nur seitenverkehrt

280a - Amset-Figur



281a - Mamu-Figur



Stoff, mit dem die Figur eingewickelt war:

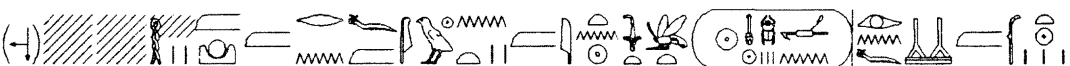

282a - Schu-Figur





283 - Kasten*

Textnachweis: Seton-Williams, Abb.66.

hieratische Inschrift auf dem Deckel des Kastens, nicht in TutTS 2:

(-)  (Transkription), nicht gesehen.

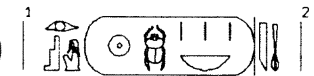
Siegel, Typ "N"

283a - Schlangenfigur(-) **283b - Sopdu-Figur**(-) **283c - Gemehsu-Figur**(-) ¹  ² **285 - Bootsmodell**

am Bug:

(-) 

am Heck:

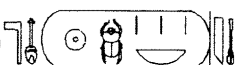
(-) **286 - Bootsmodell (Texte wie 285, aber seitenverkehrt)****289a - König auf Panther**(+) **289b - König auf Panther**(-) 

296a - Menkaret-Figur



296b - Königsfigur



297a - Cheper-Figur



298a - Chenti-Chem-Figur

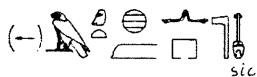

299a - Geb-Figur



300a - Sachmet-Figur



Inscription auf dazugehörigem Leinentuch:



darunter evtl. Spuren einer weiteren Inschrift. Nicht lesbar.

301a - Hapi-Figur



302a - Duamutef-Figur



303a - Tata-Figur





305a - Nephthys-Figur

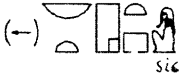

307 - Bootsmodell*



311 - Bootsmodell

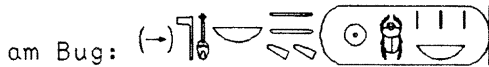

317a - Kindersarg (äußerer Sarg)

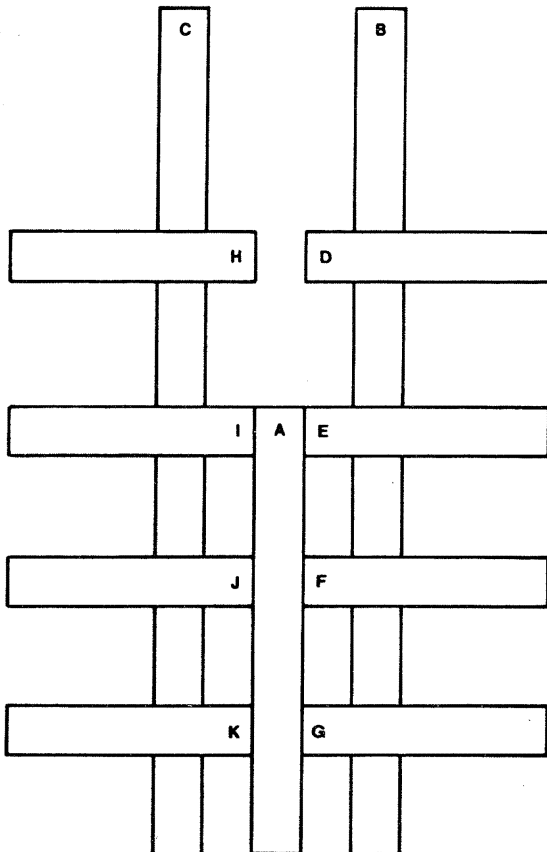

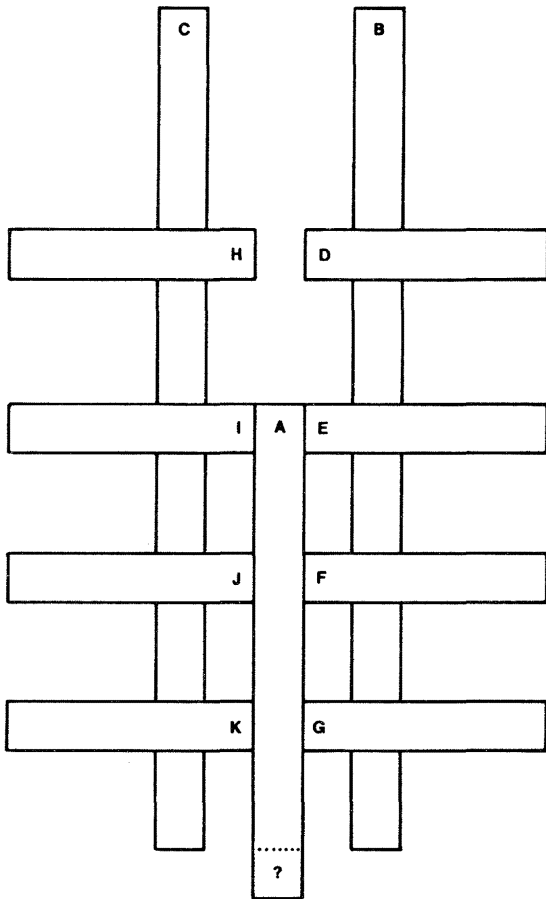

linke Körperseite (B)

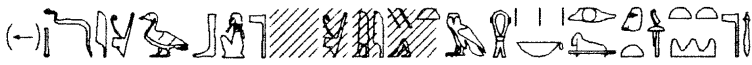

rechte Körperseite (C)



Querstreifen linke Körperseite

- (D) (H)
- (E) (H)
- (F) (H)
- (G) (H)

Querstreifen rechte Körperseite

- (H) (H)
- (I) (H)

rechte Körperseite (C)



Querstreifen linke Körperseite

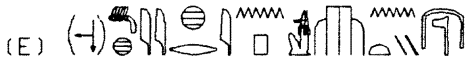

Querstreifen rechte Körperseite

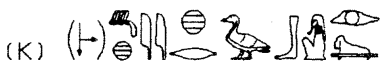
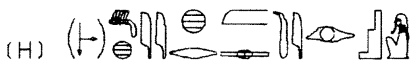

unter den Sohlen

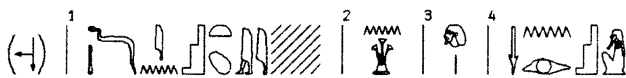

318a/60830 - Uschebti

Textnachweis: Deutschland 80/81, Nr.17; USA, Nr.42.

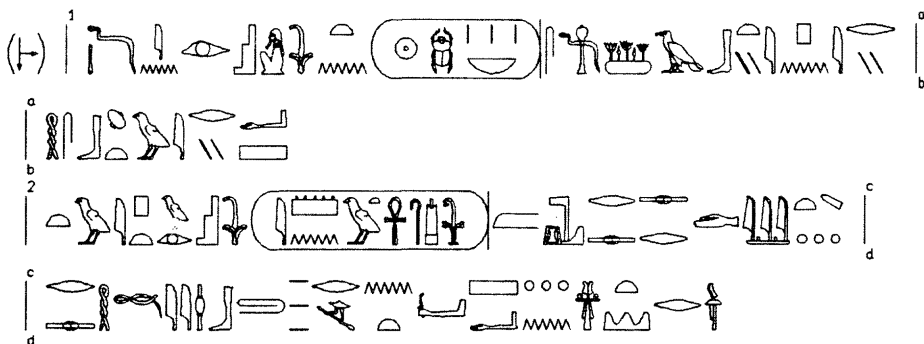

auf den Fußsohlen:

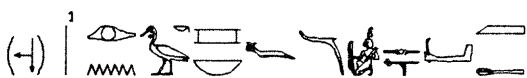



318b/60826 - Uschebti

Textnachweis: Seton-Williams, Abb.56 (rechts).

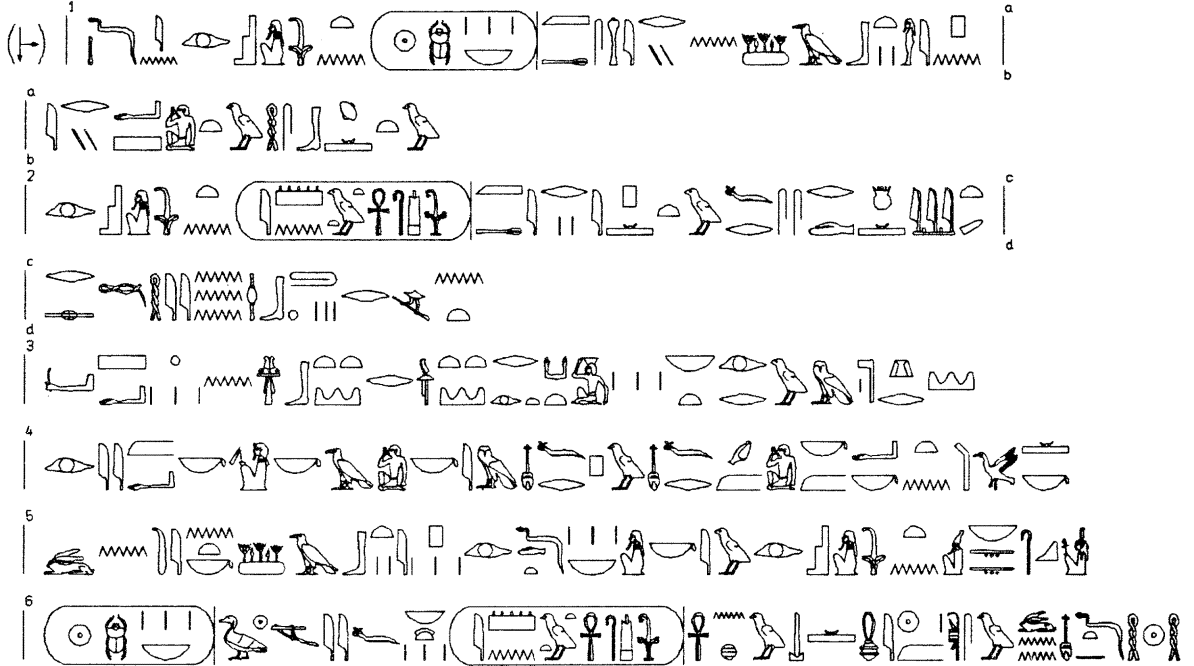

auf den Fußsohlen:

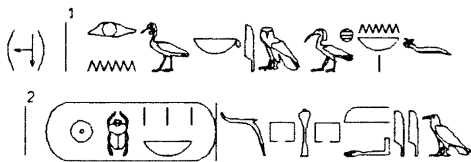

318c/60837 - Uschebti

Textnachweis: Desroches-Noblecourt, Abb.163 (2. von rechts).

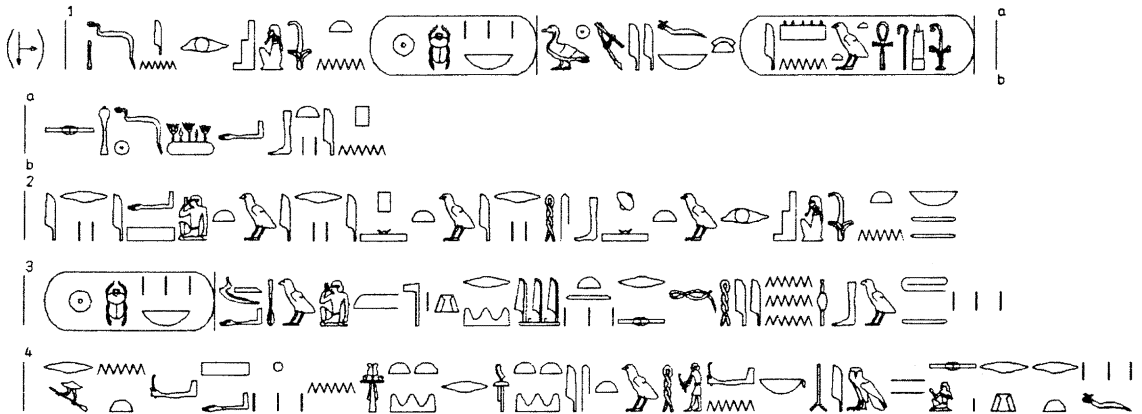

auf den Fußsohlen:



319k/60942 - Uschebti

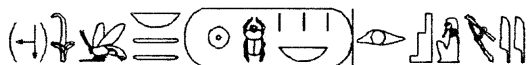

319l/60943 - Uschebti



319m/60875 - Uschebti



319n/60896 - Uschebti



319o/60907 - Uschebti



320 - Modell-Sarg (Äußerer Sarg)

zentrale Inschrift



Querstreifen linke Körperseite (von oben nach unten)



Querstreifen rechte Körperseite (von oben nach unten)





320a - Modellsarg (Innerer Sarg)

Textnachweis: London, Nr.47; UDSSR, Nr.10.

zentrale Inschrift



unter den Sohlen

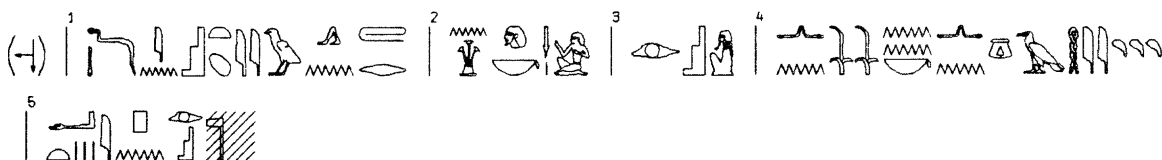

320d - Modellsarg*

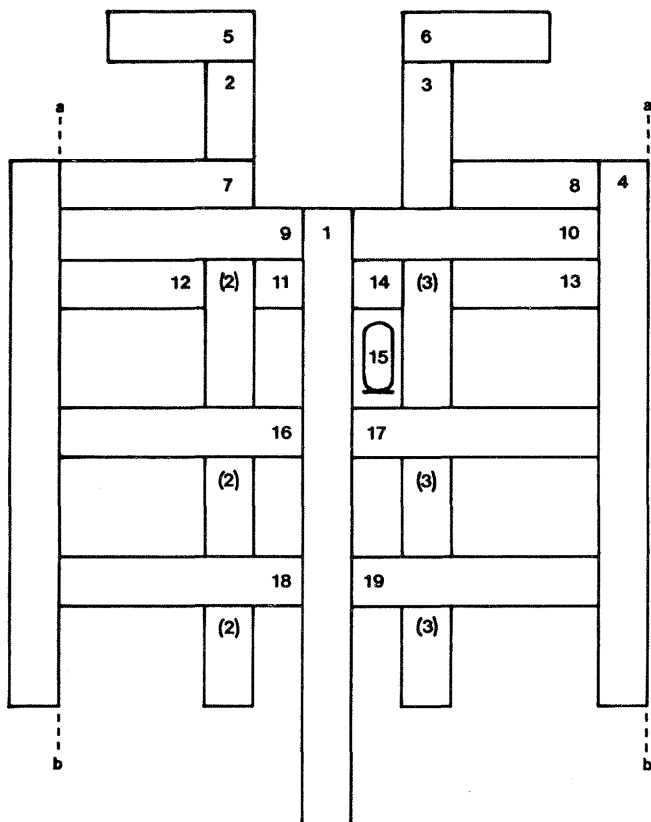

zentrale Inschrift auf der Vorderseite

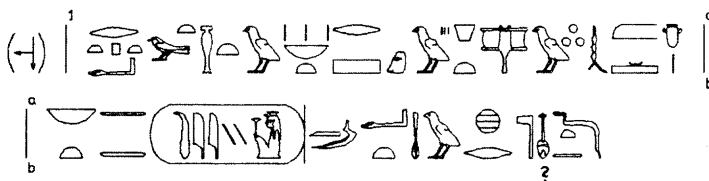

322d/61009 - Uschebti



322e/60990 - Uschebti



322f/60991 - Uschebti

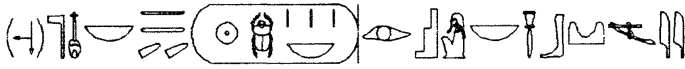

322g/61041 - Uschebti



322h/61042 - Uschebti



322i/61019 - Uschebti



322j/61039 - Uschebti

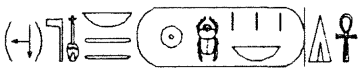

323a/60855 - Uschebti



323b/60856 - Uschebti



323c/60863 - Uschebti



323d/60858 - Uschebti

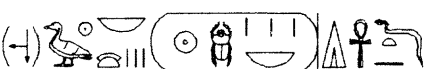

323e/60862 - Uschebti



323f/60861 - Uschebti



323g/60870 - Uschebti



323h ? /60871 - Uschebti



323i/60872 - Uschebti



323j ? /60864 - Uschebti



323k ? /60869 - Uschebti



323l/60852 - Uschebti



323m ? /60853 - Uschebti

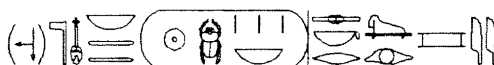

323n/60851 - Uschebti



323o/60930 - Uschebti



323p/60897 - Uschebti

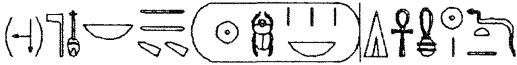

324a/60918 - Uschebti



324b/60919 - Uschebti



324c ? /60923 - Uschebti

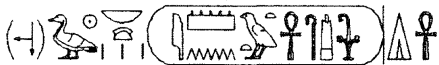

324d/60924 - Uschebti



324e/60925 - Uschebti

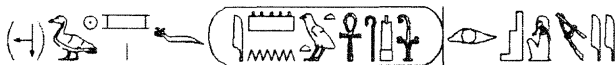

324f/60926 - Uschebti



324g/60898 - Uschebti



324h/60905 - Uschebti



324i/60906 - Uschebti

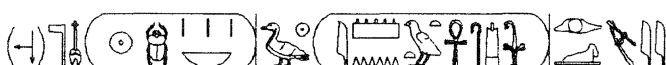

324j/60908 - Uschebti

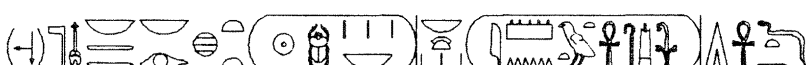

324k/60909 - Uschebti

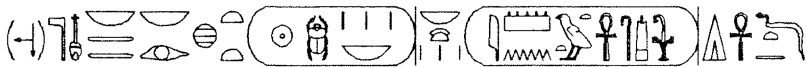

324l/60910 - Uschebti



324m/60899 - Uschebti



324n/60911 - Uschebti



324o/60912 - Uschebti



324p/60917 - Uschebti



324q ? /60900 - Uschebti

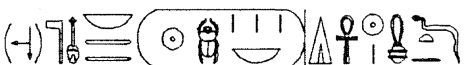

324r ? /60901 - Uschebti



324s/60931 - Uschebti



324t/60932 - Uschebti

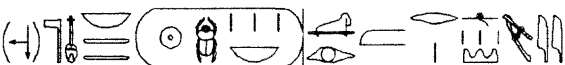

325a/60838 - Uschebti

Textnachweis: UDSSR, Nr.15; Seton-Williams, Abb.56 (links);
Lange, Pyramiden, Abb.44 (rechts); Riesterer, Abb.25 (rechts).

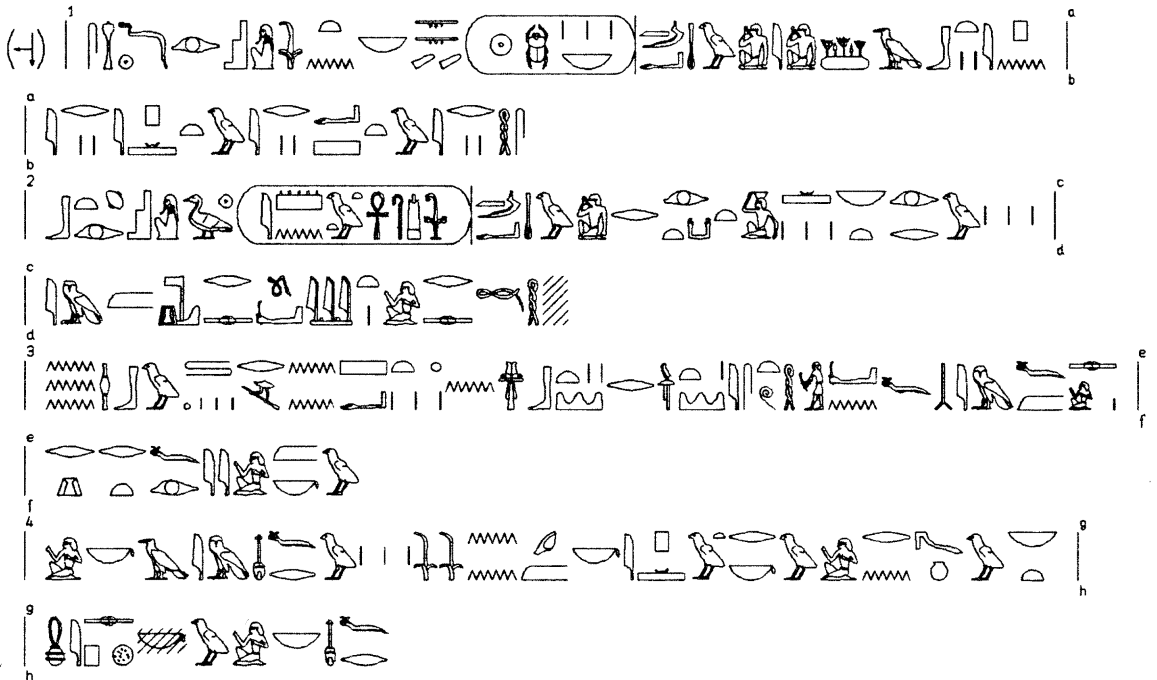

325b/60839 - Uschebti

Textnachweis: Japan, Nr.42; Lange, Pyramiden, Abb.44 (links);
Riesterer, Abb.25 (links).

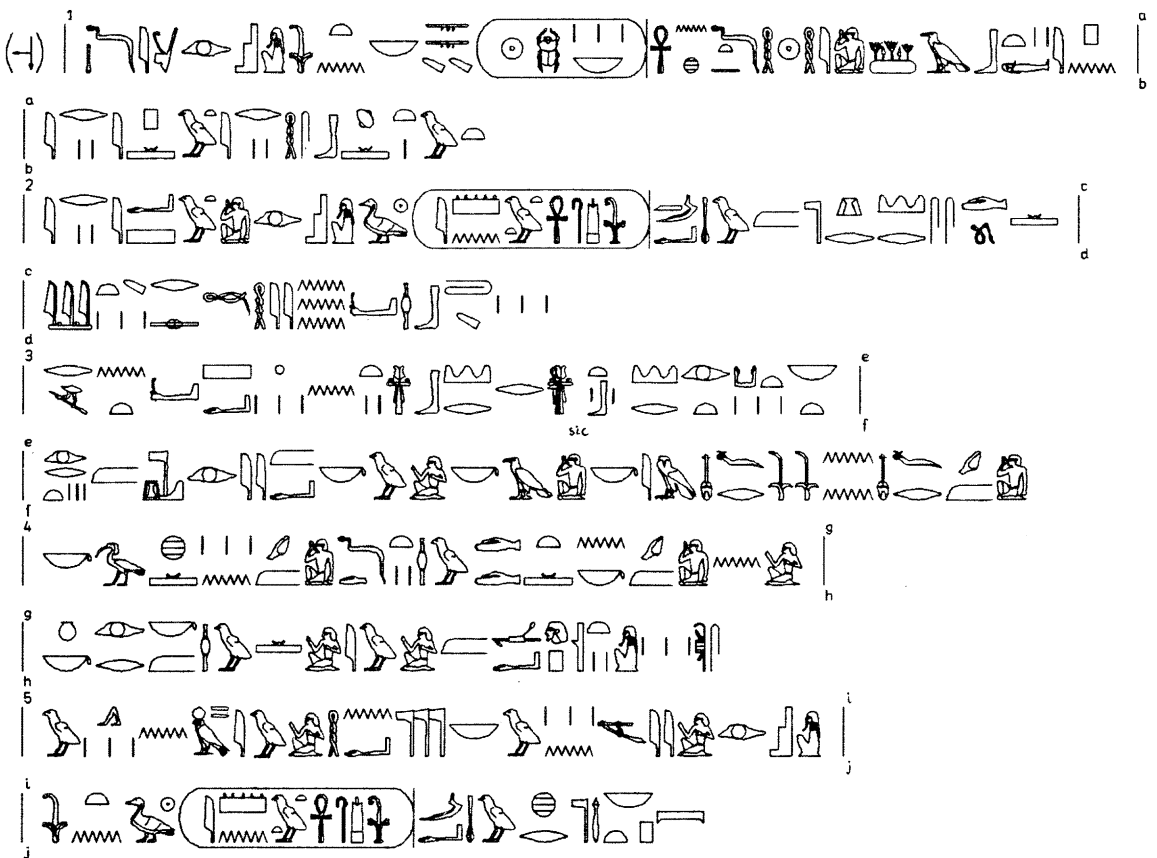

325c ?/60764 - Uschebti



325d ?/60765 - Uschebti



325e/60779 - Uschebti

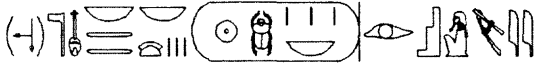

325f/61122 - Uschebti



326a/60835 - Uschebti

Textnachweis: Lange, Pyramiden, Abb.44 (Mitte);
Riesterer, Abb.25 (Mitte); Wien, Nr.59.

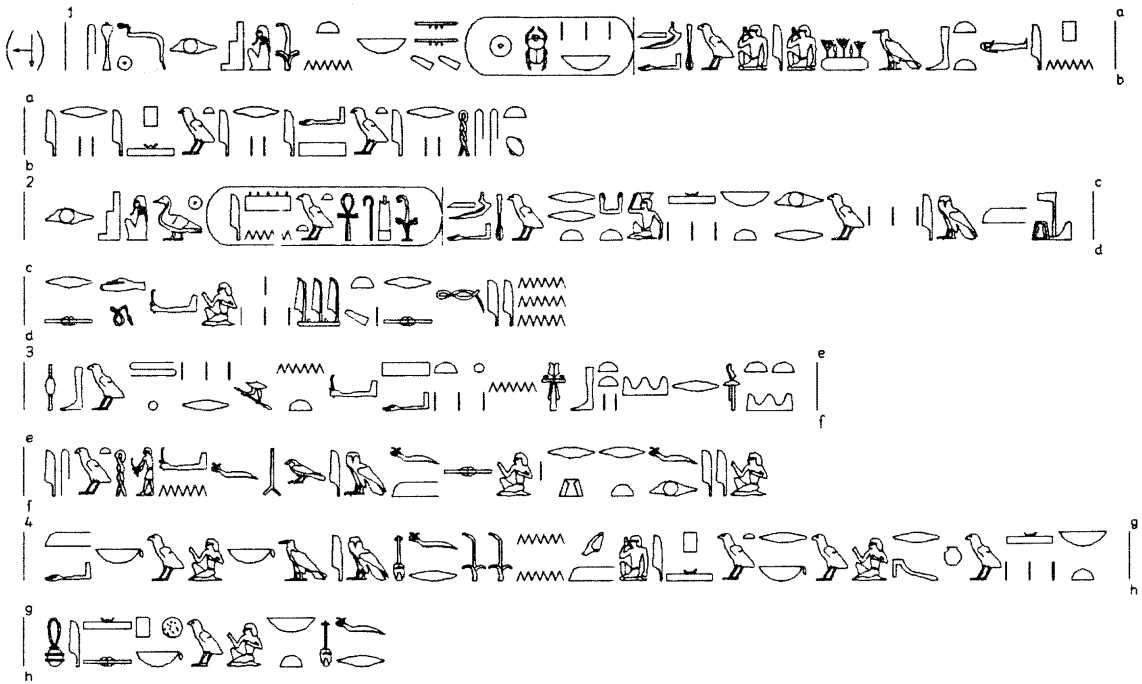

326b/60808 - Uschebti



326c/61051 - Uschebti



326d/61052 - Uschebti



326e/61053 - Uschebti



326f/61055 - Uschebti



326g ? /61056 - Uschebti

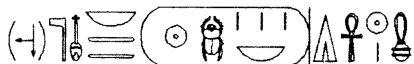

326h/61057 - Uschebti

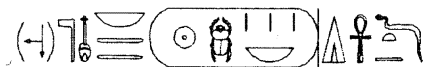

326i/61058 - Uschebti

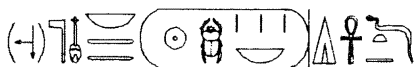

326j/61059 - Uschebti

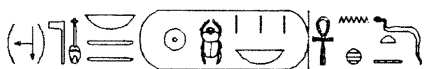

326k/61060 - Uschebti



326l ? /61061 - Uschebti



326m/61062 - Uschebti

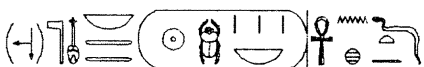

326n/61063 - Uschebti



326o/61064 - Uschebti

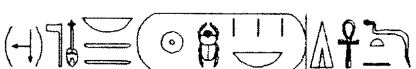

326p/61090 - Uschebti

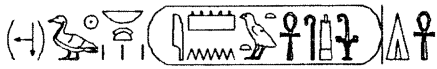

326q/61099 - Uschebti

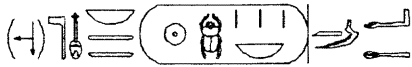

326r ? /61100 - Uschebti

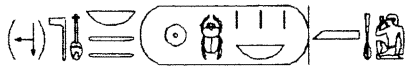

326s/61101 - Uschebti

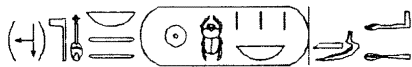

326t ? /61102 - Uschebti

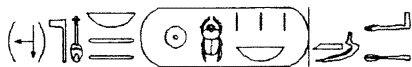

326u/61103 - Uschebti



326v ? /61123 - Uschebti



326w/61124 - Uschebti

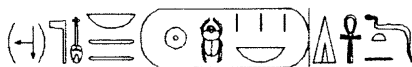

326x/61144 - Uschebti



326y/61125 - Uschebti



327a/61153 - Uschebti

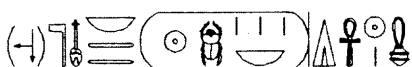

327b/61154 - Uschebti

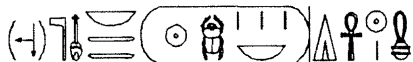

327c/61155 - Uschebti

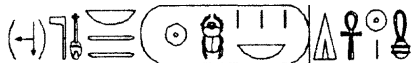

327d ? /61156 - Uschebti

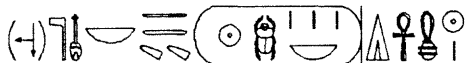

327e ? /61157 - Uschebti



327f/61158 - Uschebti

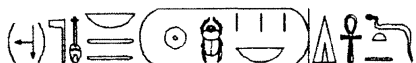

327g/61159 - Uschebti



327h/61105 - Uschebti

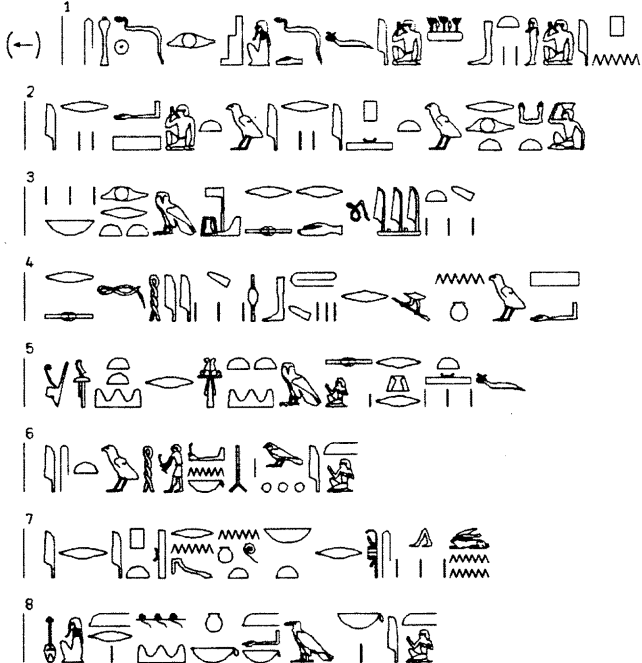

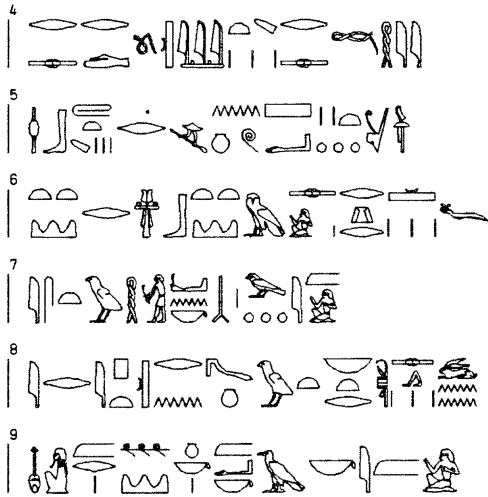

327l/61147 - Uschebti



327m/61148 - Uschebti

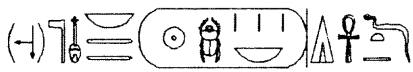

327n/61149 - Uschebti



327o/61126 - Uschebti



327p/61127 - Uschebti

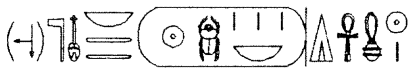

327q/61150 - Uschebti



327r/61151 - Uschebti

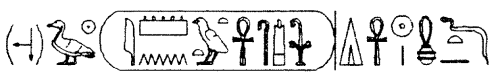

327s/61145 - Uschebti



327t/61146 - Uschebti



327u/61128 - Uschebti

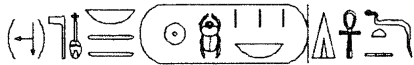

327v/61129 - Uschebti



327w/61130 - Uschebti

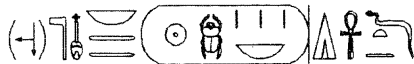

327x/61131 - Uschebti

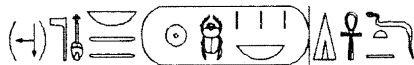

327y/61132 - Uschebti

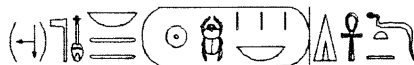

327z/61133 - Uschebti

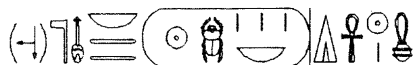

327aa/61134 - Uschebti



327bb/61135 - Uschebti



327cc/61136 - Uschebti



327dd/61137 - Uschebti

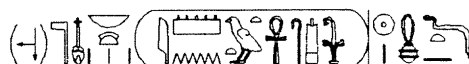

327ee/61112 - Uschebti



327ff/61113 - Uschebti



327gg/61114 - Uschebti



327hh ? /61138 - Uschebti



327li ? /61115 - Uschebti



327jj/61116 - Uschebti



327kk/61117 - Uschebti

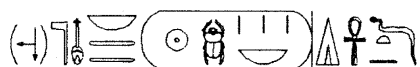

327ll/61118 - Uschebti

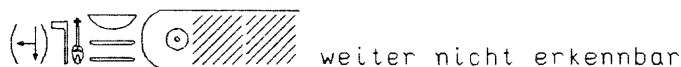

327mm ? /61120 - Uschebti



weiter nicht erkennbar

327nn/61121 - Uschebti



328a/60985 - Uschebti



328b/60962 - Uschebti



328c/60956 - Uschebti

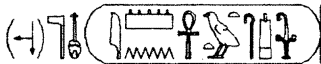

328d/60955 - Uschebti

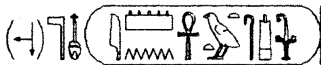

328e ? /60965 - Uschebti



328f ? /60949 - Uschebti



328g ? /60954 - Uschebti



328h/60979 - Uschebti



328i/60980 - Uschebti



328j/60981 - Uschebti



328k/60988 - Uschebti



328l/60970 - Uschebti

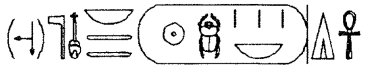

328m/60982 - Uschebti



328n ? /60968 - Uschebti



329a/60992 - Uschebti



329b/60993 - Uschebti

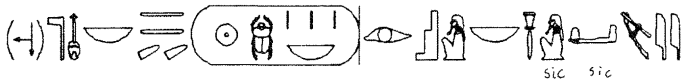

329c/60994 - Uschebti



329d/60995 - Uschebti



329e/61010 - Uschebti



329f/61011 - Uschebti



329g/61012 - Uschebti



329h/61024 - Uschebti



329i/61025 - Uschebti



329j/61026 - Uschebti



329k ? /61027 - Uschebti



329l/61045 - Uschebti

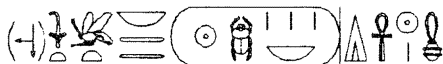

330 - Holzkasten

Hieratische Inschrift TutTS 2, Nr. 55

330a/60820 - Uschebti

Textnachweis: Seton-Williams, Abb.57 (rechts);

Desroches-Noblecourt, Taf.35.

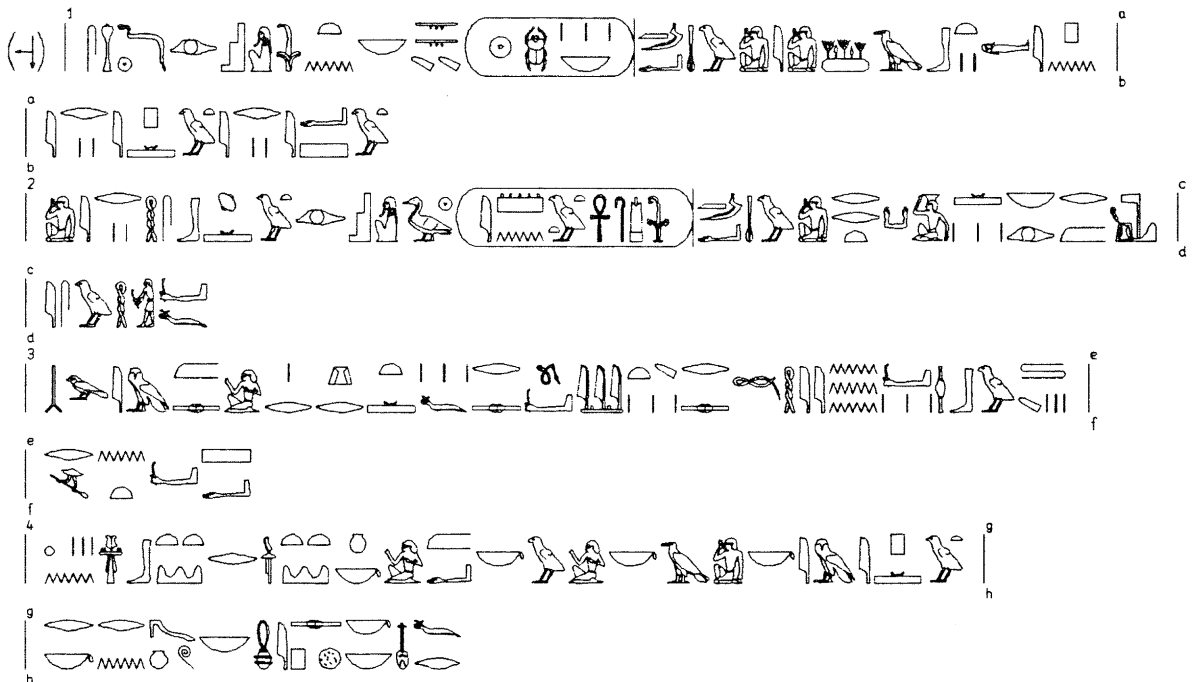

330b/60821 - Uschebti

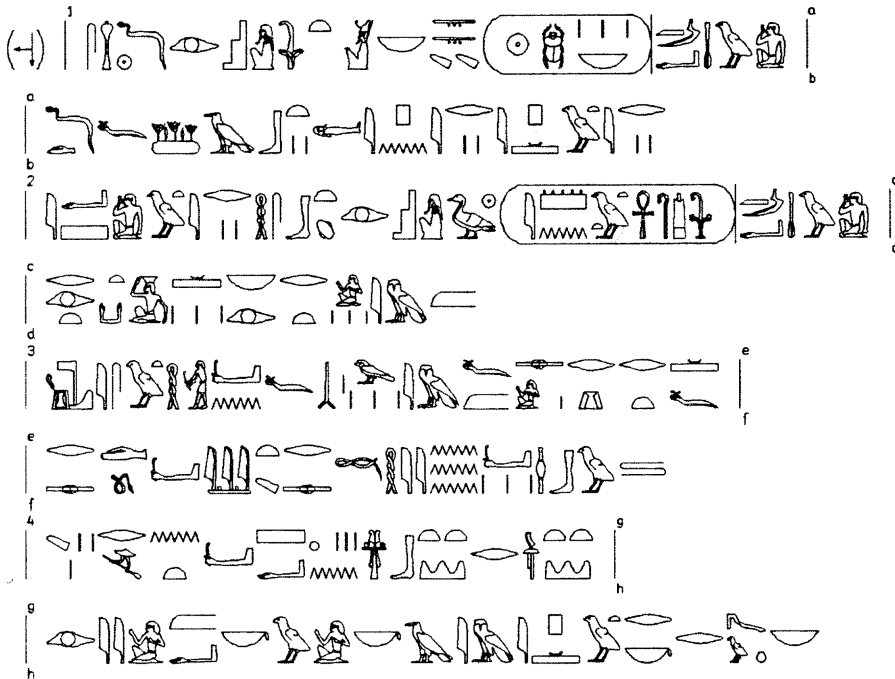

330c/60823 - Uschebti

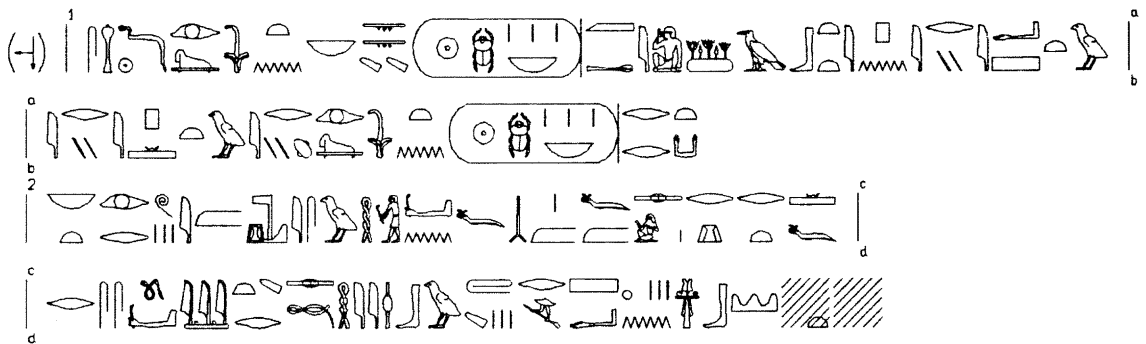

330d/60822 - Uschebti

Textnachweis: Seton-Williams, Abb.57 (links).

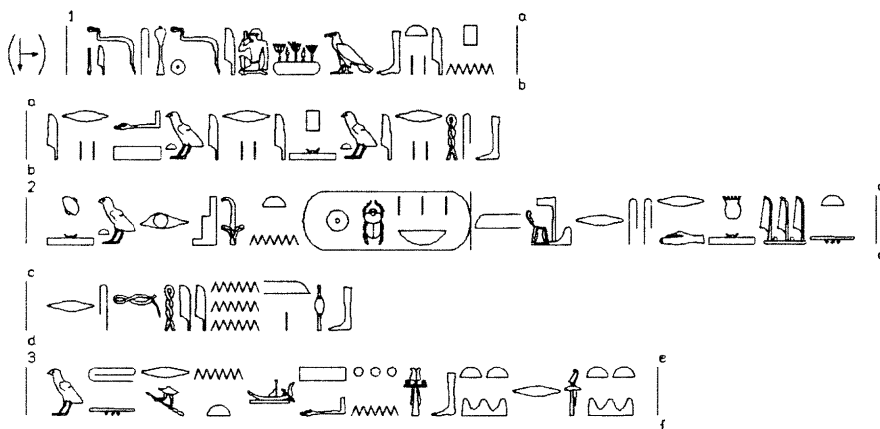

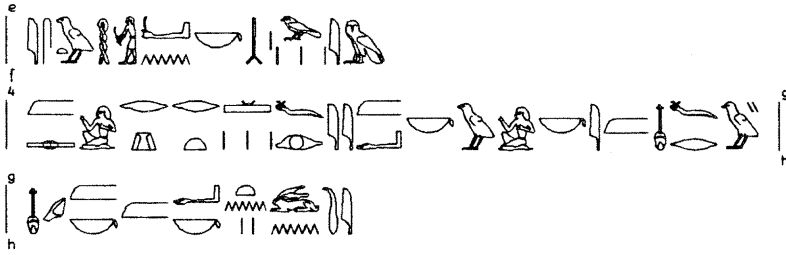

330e/60824a - Uschebti

Textnachweis: Desroches-Noblecourt, Abb.163 (3. von links).

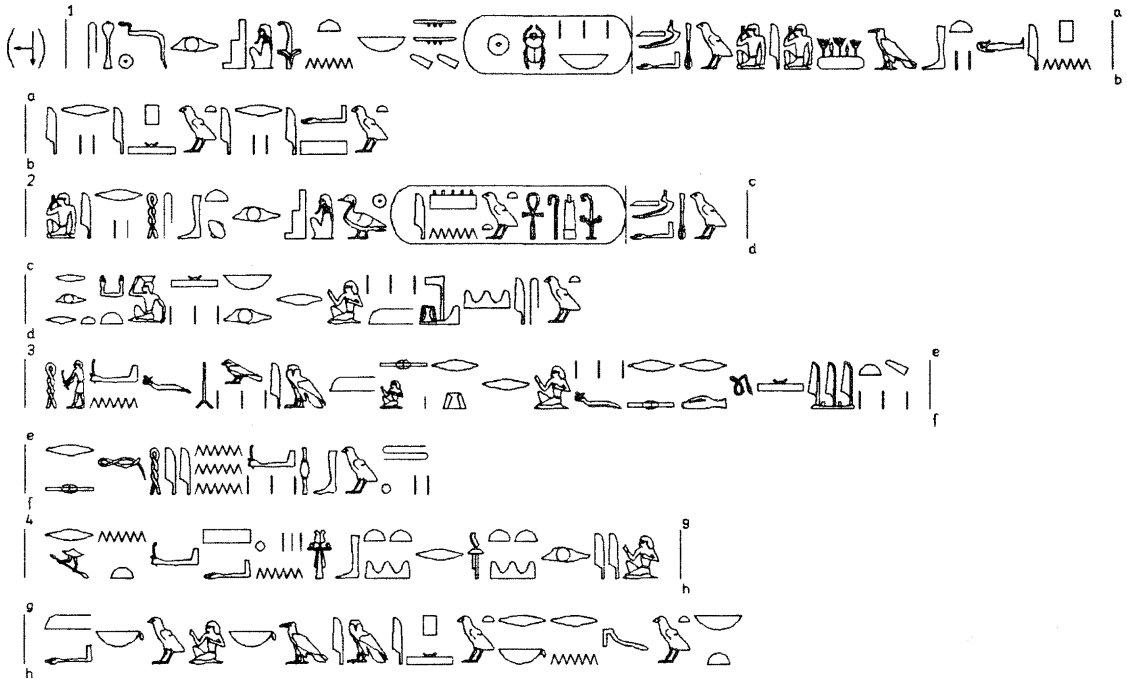

330f/60824b - Uschebti

Textnachweis: Spanien, Nr.52.

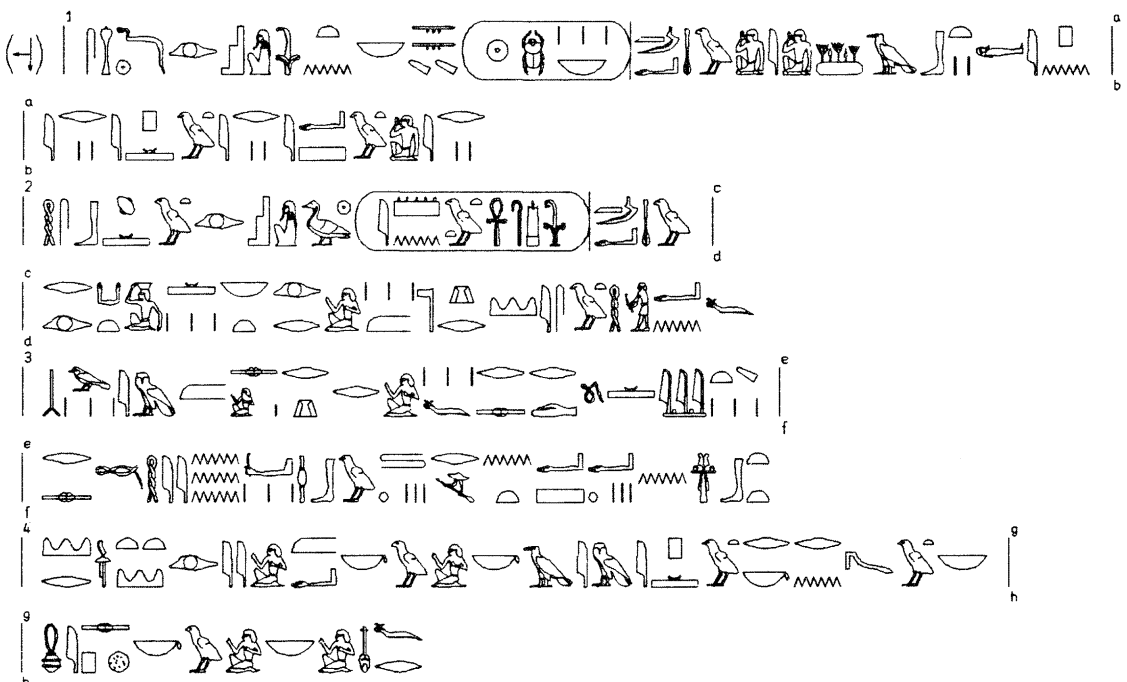

330g/60834 - Uschebti

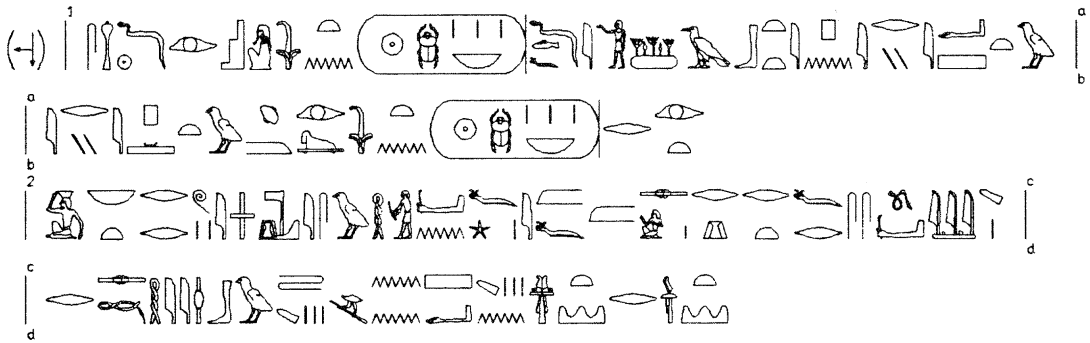

330h/60833 - Uschebti

Textnachweis: Desroches-Noblecourt, Abb.163 (4. von links).

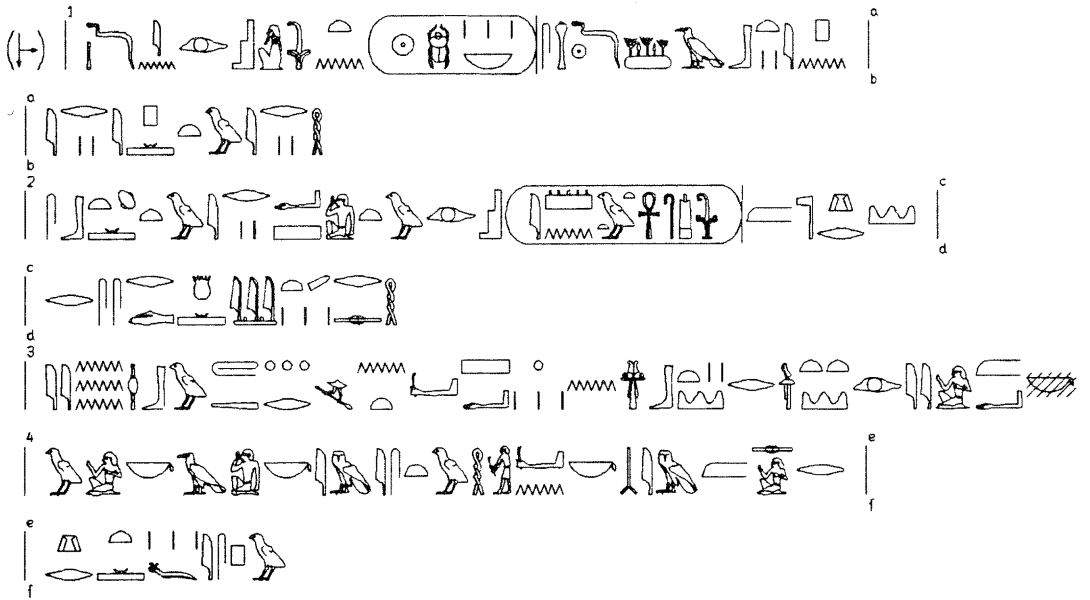

330i/60827 - Uschebti

Textnachweis: Desroches-Noblecourt, Abb.163 (1. von links).

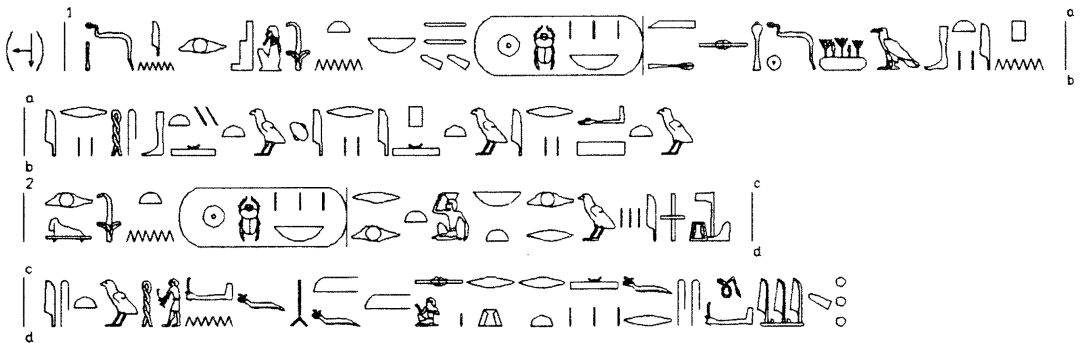

auf den Fußsohlen:

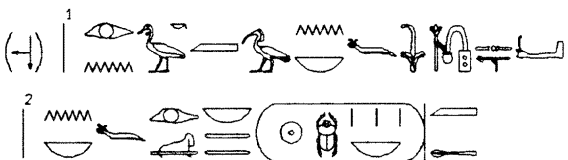

330j/60828 - Uschebti

Textnachweis: USA 61/63, Nr.17; London, Nr.11.

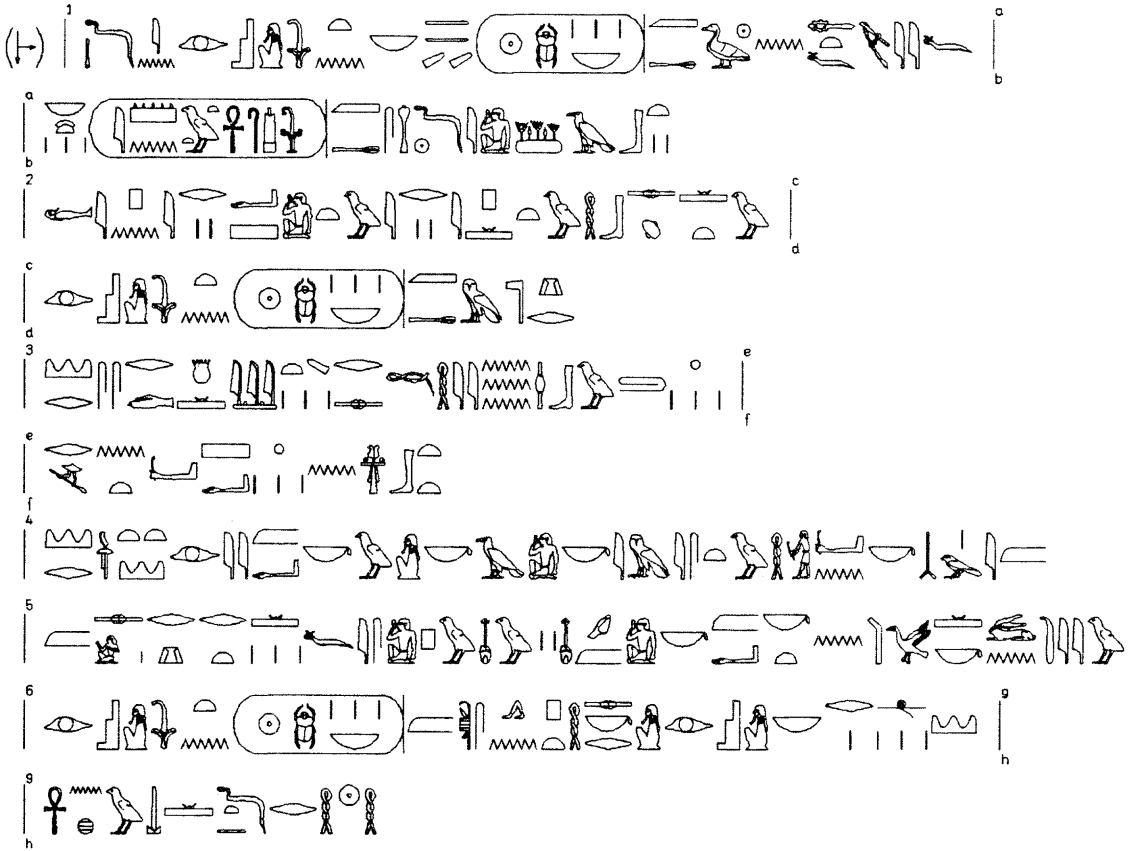

auf den Fußsohlen:

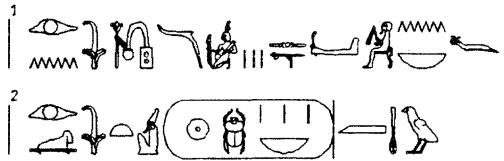

330k/60836 - Uschebti

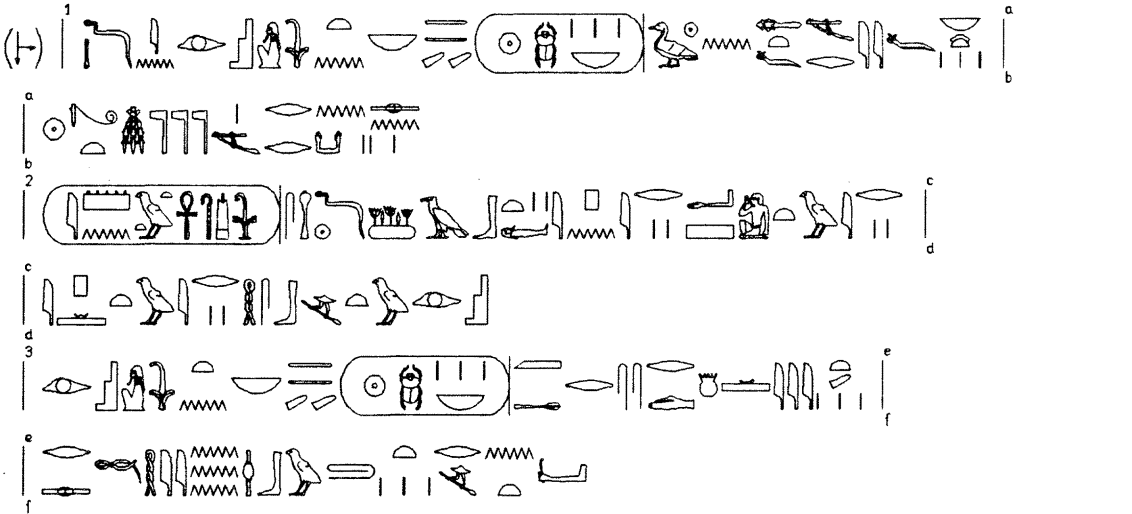

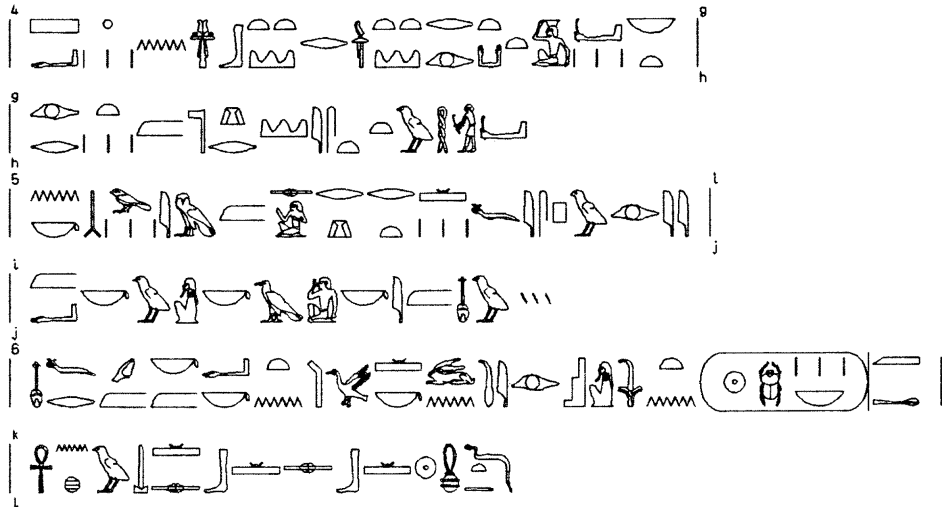

auf den Fußsohlen:

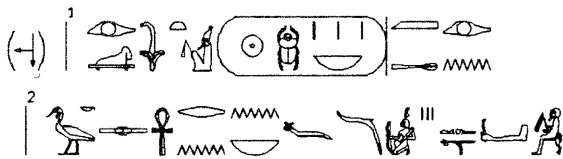

330l/61049 - Uschebti



330m/61050 - Uschebti



330n/61046 - Uschebti



330o ? /61048 - Uschebti



331a - Miniatur einer aufgebahrten Mumie

Textnachweis: Seton-Williams, Abb.59; Deutschland 80/81, Nr.15;
 Edwards, S.184f.; Paris, Nr.34; Fox, Schatz, Abb.63;
 Fox, Treasure, Abb.55; London, Nr.10.

Zentrum:



A
 (-) 𐎗𐎛𐎠𐎡𐎢𐎣𐎤𐎥𐎦𐎧𐎨𐎩𐎪𐎫𐎬𐎭𐎮𐎯𐎰𐎱𐎲𐎳𐎴𐎵𐎶𐎷𐎸𐎹𐎺𐎻𐎼𐎽𐎾𐎿𐏀𐏁𐏂𐏃𐏄𐏅𐏆𐏇𐏈𐏉𐏊𐏋𐏌𐏍𐏎𐏏𐏐𐏑𐏒𐏓𐏔𐏕𐏖𐏗𐏘𐏙𐏚𐏛𐏜𐏝𐏞𐏟𐏠𐏡𐏢𐏣𐏤𐏥𐏦𐏧𐏨𐏩𐏪𐏫𐏬𐏭𐏮𐏯𐏰𐏱𐏲𐏳𐏴𐏵𐏶𐏷𐏸𐏹𐏺𐏻𐏼𐏽𐏾𐏿𐐀𐐁𐐂𐐃𐐄𐐅𐐆𐐇𐐈𐐉𐐊𐐋𐐌𐐍𐐎𐐏𐐐𐐑𐐒𐐓𐐔𐐕𐐖𐐗𐐘𐐙𐐚𐐛𐐜𐐝𐐞𐐟𐐠𐐡𐐢𐐣𐐤𐐥𐐦𐐧𐐨𐐩𐐪𐐫𐐬𐐭𐐮𐐯𐐰𐐱𐐲𐐳𐐴𐐵𐐶𐐷𐐸𐐹𐐺𐐻𐐼𐐽𐐾𐐿𐑀𐑁𐑂𐑃𐑄𐑅𐑆𐑇𐑈𐑉𐑊𐑋𐑌𐑍𐑎𐑏𐑐𐑑𐑒𐑓𐑔𐑕𐑖𐑗𐑘𐑙𐑚𐑛𐑜𐑝𐑞𐑟𐑠𐑡𐑢𐑣𐑤𐑥𐑦𐑧𐑨𐑩𐑪𐑫𐑬𐑭𐑮𐑯𐑰𐑱𐑲𐑳𐑴𐑵𐑶𐑷𐑸𐑹𐑺𐑻𐑼𐑽𐑾𐑿𐒀𐒁𐒂𐒃𐒄𐒅𐒆𐒇𐒈𐒉𐒊𐒋𐒌𐒍𐒎𐒏𐒐𐒑𐒒𐒓𐒔𐒕𐒖𐒗𐒘𐒙𐒚𐒛𐒜𐒝𐒞𐒟𐒠𐒡𐒢𐒣𐒤𐒥𐒦𐒧𐒨𐒩𐒪𐒫𐒬𐒭𐒮𐒯𐒰𐒱𐒲𐒳𐒴𐒵𐒶𐒷𐒸𐒹𐒺𐒻𐒼𐒽𐒾𐒿𐓀𐓁𐓂𐓃𐓄𐓅𐓆𐓇𐓈𐓉𐓊𐓋𐓌𐓍𐓎𐓏𐓐𐓑𐓒𐓓𐓔𐓕𐓖𐓗𐓘𐓙𐓚𐓛𐓜𐓝𐓞𐓟𐓠𐓡𐓢𐓣𐓤𐓥𐓦𐓧𐓨𐓩𐓪𐓫𐓬𐓭𐓮𐓯𐓰𐓱𐓲𐓳𐓴𐓵𐓶𐓷𐓸𐓹𐓺𐓻𐓼𐓽𐓾𐓿𐔀𐔁𐔂𐔃𐔄𐔅𐔆𐔇𐔈𐔉𐔊𐔋𐔌𐔍𐔎𐔏𐔐𐔑𐔒𐔓𐔔𐔕𐔖𐔗𐔘𐔙𐔚𐔛𐔜𐔝𐔞𐔟𐔠𐔡𐔢𐔣𐔤𐔥𐔦𐔧𐔨𐔩𐔪𐔫𐔬𐔭𐔮𐔯𐔰𐔱𐔲𐔳𐔴𐔵𐔶𐔷𐔸𐔹𐔺𐔻𐔼𐔽𐔾𐔿𐕀𐕁𐕂𐕃𐕄𐕅𐕆𐕇𐕈𐕉𐕊𐕋𐕌𐕍𐕎𐕏𐕐𐕑𐕒𐕓𐕔𐕕𐕖𐕗𐕘𐕙𐕚𐕛𐕜𐕝𐕞𐕟𐕠𐕡𐕢𐕣𐕤𐕥𐕦𐕧𐕨𐕩𐕪𐕫𐕬𐕭𐕮𐕯𐕰𐕱𐕲𐕳𐕴𐕵𐕶𐕷𐕸𐕹𐕺𐕻𐕼𐕽𐕾𐕿𐖀𐖁𐖂𐖃𐖄𐖅𐖆𐖇𐖈𐖉𐖊𐖋𐖌𐖍𐖎𐖏𐖐𐖑𐖒𐖓𐖔𐖕𐖖𐖗𐖘𐖙𐖚𐖛𐖜𐖝𐖞𐖟𐖠𐖡𐖢𐖣𐖤𐖥𐖦𐖧𐖨𐖩𐖪𐖫𐖬𐖭𐖮𐖯𐖰𐖱𐖲𐖳𐖴𐖵𐖶𐖷𐖸𐖹𐖺𐖻𐖼𐖽𐖾𐖿𐗀𐗁𐗂𐗃𐗄𐗅𐗆𐗇𐗈𐗉𐗊𐗋𐗌𐗍𐗎𐗏𐗐𐗑𐗒𐗓𐗔𐗕𐗖𐗗𐗘𐗙𐗚𐗛𐗜𐗝𐗞𐗟𐗠𐗡𐗢𐗣𐗤𐗥𐗦𐗧𐗨𐗩𐗪𐗫𐗬𐗭𐗮𐗯𐗰𐗱𐗲𐗳𐗴𐗵𐗶𐗷𐗸𐗹𐗺𐗻𐗼𐗽𐗾𐗿𐘀𐘁𐘂𐘃𐘄𐘅𐘆𐘇𐘈𐘉𐘊𐘋𐘌𐘍𐘎𐘏𐘐𐘑𐘒𐘓𐘔𐘕𐘖𐘗𐘘𐘙𐘚𐘛𐘜𐘝𐘞𐘟𐘠𐘡𐘢𐘣𐘤𐘥𐘦𐘧𐘨𐘩𐘪𐘫𐘬𐘭𐘮𐘯𐘰𐘱𐘲𐘳𐘴𐘵𐘶𐘷𐘸𐘹𐘺𐘻𐘼𐘽𐘾𐘿𐙀𐙁𐙂𐙃𐙄𐙅𐙆𐙇𐙈𐙉𐙊𐙋𐙌𐙍𐙎𐙏𐙐𐙑𐙒𐙓𐙔𐙕𐙖𐙗𐙘𐙙𐙚𐙛𐙜𐙝𐙞𐙟𐙠𐙡𐙢𐙣𐙤𐙥𐙦𐙧𐙨𐙩𐙪𐙫𐙬𐙭𐙮𐙯𐙰𐙱𐙲𐙳𐙴𐙵𐙶𐙷𐙸𐙹𐙺𐙻𐙼𐙽𐙾𐙿𐚀𐚁𐚂𐚃𐚄𐚅𐚆𐚇𐚈𐚉𐚊𐚋𐚌𐚍𐚎𐚏𐚐𐚑𐚒𐚓𐚔𐚕𐚖𐚗𐚘𐚙𐚚𐚛𐚜𐚝𐚞𐚟𐚠𐚡𐚢𐚣𐚤𐚥𐚦𐚧𐚨𐚩𐚪𐚫𐚬𐚭𐚮𐚯𐚰𐚱𐚲𐚳𐚴𐚵𐚶𐚷𐚸𐚹𐚺𐚻𐚼𐚽𐚾𐚿𐛀𐛁𐛂𐛃𐛄𐛅𐛆𐛇𐛈𐛉𐛊𐛋𐛌𐛍𐛎𐛏𐛐𐛑𐛒𐛓𐛔𐛕𐛖𐛗𐛘𐛙𐛚𐛛𐛜𐛝𐛞𐛟𐛠𐛡𐛢𐛣𐛤𐛥𐛦𐛧𐛨𐛩𐛪𐛫𐛬𐛭𐛮𐛯𐛰𐛱𐛲𐛳𐛴𐛵𐛶𐛷𐛸𐛹𐛺𐛻𐛼𐛽𐛾𐛿𐜀𐜁𐜂𐜃𐜄𐜅𐜆𐜇𐜈𐜉𐜊𐜋𐜌𐜍𐜎𐜏𐜐𐜑𐜒𐜓𐜔𐜕𐜖𐜗𐜘𐜙𐜚𐜛𐜜𐜝𐜞𐜟𐜠𐜡𐜢𐜣𐜤𐜥𐜦𐜧𐜨𐜩𐜪𐜫𐜬𐜭𐜮𐜯𐜰𐜱𐜲𐜳𐜴𐜵𐜶𐜷𐜸𐜹𐜺𐜻𐜼𐜽𐜾𐜿𐝀𐝁𐝂𐝃𐝄𐝅𐝆𐝇𐝈𐝉𐝊𐝋𐝌𐝍𐝎𐝏𐝐𐝑𐝒𐝓𐝔𐝕𐝖𐝗𐝘𐝙𐝚𐝛𐝜𐝝𐝞𐝟𐝠𐝡𐝢𐝣𐝤𐝥𐝦𐝧𐝨𐝩𐝪𐝫𐝬𐝭𐝮𐝯𐝰𐝱𐝲𐝳𐝴𐝵𐝶𐝷𐝸𐝹𐝺𐝻𐝼𐝽𐝾𐝿𐞀𐞁𐞂𐞃𐞄𐞅𐞆𐞇𐞈𐞉𐞊𐞋𐞌𐞍𐞎𐞏𐞐𐞑𐞒𐞓𐞔𐞕𐞖𐞗𐞘𐞙𐞚𐞛𐞜𐞝𐞞𐞟𐞠𐞡𐞢𐞣𐞤𐞥𐞦𐞧𐞨𐞩𐞪𐞫𐞬𐞭𐞮𐞯𐞰𐞱𐞲𐞳𐞴𐞵𐞶𐞷𐞸𐞹𐞺𐞻𐞼𐞽𐞾𐞿𐟀𐟁𐟂𐟃𐟄𐟅𐟆𐟇𐟈𐟉𐟊𐟋𐟌𐟍𐟎𐟏𐟐𐟑𐟒𐟓𐟔𐟕𐟖𐟗𐟘𐟙𐟚𐟛𐟜𐟝𐟞𐟟𐟠𐟡𐟢𐟣𐟤𐟥𐟦𐟧𐟨𐟩𐟪𐟫𐟬𐟭𐟮𐟯𐟰𐟱𐟲𐟳𐟴𐟵𐟶𐟷𐟸𐟹𐟺𐟻𐟼𐟽𐟾𐟿𐠀𐠁𐠂𐠃𐠄𐠅𐠆𐠇𐠈𐠉𐠊𐠋𐠌𐠍𐠎𐠏𐠐𐠑𐠒𐠓𐠔𐠕𐠖𐠗𐠘𐠙𐠚𐠛𐠜𐠝𐠞𐠟𐠠𐠡𐠢𐠣𐠤𐠥𐠦𐠧𐠨𐠩𐠪𐠫𐠬𐠭𐠮𐠯𐠰𐠱𐠲𐠳𐠴𐠵𐠶𐠷𐠸𐠹𐠺𐠻𐠼𐠽𐠾𐠿𐡀𐡁𐡂𐡃𐡄𐡅𐡆𐡇𐡈𐡉𐡊𐡋𐡌𐡍𐡎𐡏𐡐𐡑𐡒𐡓𐡔𐡕𐡖𐡗𐡘𐡙𐡚𐡛𐡜𐡝𐡞𐡟𐡠𐡡𐡢𐡣𐡤𐡥𐡦𐡧𐡨𐡩𐡪𐡫𐡬𐡭𐡮𐡯𐡰𐡱𐡲𐡳𐡴𐡵𐡶𐡷𐡸𐡹𐡺𐡻𐡼𐡽𐡾𐡿𐢀𐢁𐢂𐢃𐢄𐢅𐢆𐢇𐢈𐢉𐢊𐢋𐢌𐢍𐢎𐢏𐢐𐢑𐢒𐢓𐢔𐢕𐢖𐢗𐢘𐢙𐢚𐢛𐢜𐢝𐢞𐢟𐢠𐢡𐢢𐢣𐢤𐢥𐢦𐢧𐢨𐢩𐢪𐢫𐢬𐢭𐢮𐢯𐢰𐢱𐢲𐢳𐢴𐢵𐢶𐢷𐢸𐢹𐢺𐢻𐢼𐢽𐢾𐢿𐣀𐣁𐣂𐣃𐣄𐣅𐣆𐣇𐣈𐣉𐣊𐣋𐣌𐣍𐣎𐣏𐣐𐣑𐣒𐣓𐣔𐣕𐣖𐣗𐣘𐣙𐣚𐣛𐣜𐣝𐣞𐣟𐣠𐣡𐣢𐣣𐣤𐣥𐣦𐣧𐣨𐣩𐣪𐣫𐣬𐣭𐣮𐣯𐣰𐣱𐣲𐣳𐣴𐣵𐣶𐣷𐣸𐣹𐣺𐣻𐣼𐣽𐣾𐣿𐤀𐤁𐤂𐤃𐤄𐤅𐤆𐤇𐤈𐤉𐤊𐤋𐤌𐤍𐤎𐤏𐤐𐤑𐤒𐤓𐤔𐤕𐤖𐤗𐤘𐤙𐤚𐤛𐤜𐤝𐤞𐤟𐤠𐤡𐤢𐤣𐤤𐤥𐤦𐤧𐤨𐤩𐤪𐤫𐤬𐤭𐤮𐤯𐤰𐤱𐤲𐤳𐤴𐤵𐤶𐤷𐤸𐤹𐤺𐤻𐤼𐤽𐤾𐤿𐥀𐥁𐥂𐥃𐥄𐥅𐥆𐥇𐥈𐥉𐥊𐥋𐥌𐥍𐥎𐥏𐥐𐥑𐥒𐥓𐥔𐥕𐥖𐥗𐥘𐥙𐥚𐥛𐥜𐥝𐥞𐥟𐥠𐥡𐥢𐥣𐥤𐥥𐥦𐥧𐥨𐥩𐥪𐥫𐥬𐥭𐥮𐥯𐥰𐥱𐥲𐥳𐥴𐥵𐥶𐥷𐥸𐥹𐥺𐥻𐥼𐥽𐥾𐥿𐦀𐦁𐦂𐦃𐦄𐦅𐦆𐦇𐦈𐦉𐦊𐦋𐦌𐦍𐦎𐦏𐦐𐦑𐦒𐦓𐦔𐦕𐦖𐦗𐦘𐦙𐦚𐦛𐦜𐦝𐦞𐦟𐦠𐦡𐦢𐦣𐦤𐦥𐦦𐦧𐦨𐦩𐦪𐦫𐦬𐦭𐦮𐦯𐦰𐦱𐦲𐦳𐦴𐦵𐦶𐦷𐦸𐦹𐦺𐦻𐦼𐦽𐦾𐦿𐧀𐧁𐧂𐧃𐧄𐧅𐧆𐧇𐧈𐧉𐧊𐧋𐧌𐧍𐧎𐧏𐧐𐧑𐧒𐧓𐧔𐧕𐧖𐧗𐧘𐧙𐧚𐧛𐧜𐧝𐧞𐧟𐧠𐧡𐧢𐧣𐧤𐧥𐧦𐧧𐧨𐧩𐧪𐧫𐧬𐧭𐧮𐧯𐧰𐧱𐧲𐧳𐧴𐧵𐧶𐧷𐧸𐧹𐧺𐧻𐧼𐧽𐧾𐧿𐨀𐨁𐨂𐨃𐨄𐨅𐨆𐨇𐨈𐨉𐨊𐨋𐨌𐨍𐨎𐨏𐨐𐨑𐨒𐨓𐨔𐨕𐨖𐨗𐨘𐨙𐨚𐨛𐨜𐨝𐨞𐨟𐨠𐨡𐨢𐨣𐨤𐨥𐨦𐨧𐨨𐨩𐨪𐨫𐨬𐨭𐨮𐨯𐨰𐨱𐨲𐨳𐨴𐨵𐨶𐨷𐨹𐨺𐨸𐨻𐨼𐨽𐨾𐨿𐩀𐩁𐩂𐩃𐩄𐩅𐩆𐩇𐩈𐩉𐩊𐩋𐩌𐩍𐩎𐩏𐩐𐩑𐩒𐩓𐩔𐩕𐩖𐩗𐩘𐩙𐩚𐩛𐩜𐩝𐩞𐩟𐩠𐩡𐩢𐩣𐩤𐩥𐩦𐩧𐩨𐩩𐩪𐩫𐩬𐩭𐩮𐩯𐩰𐩱𐩲𐩳𐩴𐩵𐩶𐩷𐩸𐩹𐩺𐩻𐩼𐩽𐩾𐩿𐪀𐪁𐪂𐪃𐪄𐪅𐪆𐪇𐪈𐪉𐪊𐪋𐪌𐪍𐪎𐪏𐪐𐪑𐪒𐪓𐪔𐪕𐪖𐪗𐪘𐪙𐪚𐪛𐪜𐪝𐪞𐪟𐪠𐪡𐪢𐪣𐪤𐪥𐪦𐪧𐪨𐪩𐪪𐪫𐪬𐪭𐪮𐪯𐪰𐪱𐪲𐪳𐪴𐪵𐪶𐪷𐪸𐪹𐪺𐪻𐪼𐪽𐪾𐪿𐫀𐫁𐫂𐫃𐫄𐫅𐫆𐫇𐫈𐫉𐫊𐫋𐫌𐫍𐫎𐫏𐫐𐫑𐫒𐫓𐫔𐫕𐫖𐫗𐫘𐫙𐫚𐫛𐫜𐫝𐫞𐫟𐫠𐫡𐫢𐫣𐫤𐫦𐫥𐫧𐫨𐫩𐫪𐫫𐫬𐫭𐫮𐫯𐫰𐫱𐫲𐫳𐫴𐫵𐫶𐫷𐫸𐫹𐫺𐫻𐫼𐫽𐫾𐫿𐬀𐬁𐬂𐬃𐬄𐬅𐬆𐬇𐬈𐬉𐬊𐬋𐬌𐬍𐬎𐬏𐬐𐬑𐬒𐬓𐬔𐬕𐬖𐬗𐬘𐬙𐬚𐬛𐬜𐬝𐬞𐬟𐬠𐬡𐬢𐬣𐬤𐬥𐬦𐬧𐬨𐬩𐬪𐬫𐬬𐬭𐬮𐬯𐬰𐬱𐬲𐬳𐬴𐬵𐬶𐬷𐬸𐬹𐬺𐬻𐬼𐬽𐬾𐬿𐭀𐭁𐭂𐭃𐭄𐭅𐭆𐭇𐭈𐭉𐭊𐭋𐭌𐭍𐭎𐭏𐭐𐭑𐭒𐭓𐭔𐭕𐭖𐭗𐭘𐭙𐭚𐭛𐭜𐭝𐭞𐭟𐭠𐭡𐭢𐭣𐭤𐭥𐭦𐭧𐭨𐭩𐭪𐭫𐭬𐭭𐭮𐭯𐭰𐭱𐭲𐭳𐭴𐭵𐭶𐭷𐭸𐭹𐭺𐭻𐭼𐭽𐭾𐭿𐮀𐮁𐮂𐮃𐮄𐮅𐮆𐮇𐮈𐮉𐮊𐮋𐮌𐮍𐮎𐮏𐮐𐮑𐮒𐮓𐮔𐮕𐮖𐮗𐮘𐮙𐮚𐮛𐮜𐮝𐮞𐮟𐮠𐮡𐮢𐮣𐮤𐮥𐮦𐮧𐮨𐮩𐮪𐮫𐮬𐮭𐮮𐮯𐮰𐮱𐮲𐮳𐮴𐮵𐮶𐮷𐮸𐮹𐮺𐮻𐮼𐮽𐮾𐮿𐯀𐯁𐯂𐯃𐯄𐯅𐯆𐯇𐯈𐯉𐯊𐯋𐯌𐯍𐯎𐯏𐯐𐯑𐯒𐯓𐯔𐯕𐯖𐯗𐯘𐯙𐯚𐯛𐯜𐯝𐯞𐯟𐯠𐯡𐯢𐯣𐯤𐯥𐯦𐯧𐯨𐯩𐯪𐯫𐯬𐯭𐯮𐯯𐯰𐯱𐯲𐯳𐯴𐯵𐯶𐯷𐯸𐯹𐯺𐯻𐯼𐯽𐯾𐯿𐰀𐰁𐰂𐰃𐰄𐰅𐰆𐰇𐰈𐰉𐰊𐰋𐰌𐰍𐰎𐰏𐰐𐰑𐰒𐰓𐰔𐰕𐰖𐰗𐰘𐰙𐰚𐰛𐰜𐰝𐰞𐰟𐰠𐰡𐰢𐰣𐰤𐰥𐰦𐰧𐰨𐰩𐰪𐰫𐰬𐰭𐰮𐰯𐰰𐰱𐰲𐰳𐰴𐰵𐰶𐰷𐰸𐰹𐰺𐰻𐰼𐰽𐰾𐰿𐱀𐱁𐱂𐱃𐱄𐱅𐱆𐱇𐱈𐱉𐱊𐱋𐱌𐱍𐱎𐱏𐱐𐱑𐱒𐱓𐱔𐱕𐱖𐱗𐱘𐱙𐱚𐱛𐱜𐱝𐱞𐱟𐱠𐱡𐱢𐱣𐱤𐱥𐱦𐱧𐱨𐱩𐱪𐱫𐱬𐱭𐱮𐱯𐱰𐱱𐱲𐱳𐱴𐱵𐱶𐱷𐱸𐱹𐱺𐱻𐱼𐱽𐱾𐱿𐲀𐲁𐲂𐲃𐲄𐲅𐲆𐲇𐲈𐲉𐲊𐲋𐲌𐲍𐲎𐲏𐲐𐲑𐲒𐲓𐲔𐲕𐲖𐲗𐲘𐲙𐲚𐲛𐲜𐲝𐲞𐲟𐲠𐲡𐲢𐲣𐲤𐲥𐲦𐲧𐲨𐲩𐲪𐲫𐲬𐲭𐲮𐲯𐲰𐲱𐲲𐲳𐲴𐲵𐲶𐲷𐲸𐲹𐲺𐲻𐲼𐲽𐲾𐲿𐳀𐳁𐳂𐳃𐳄𐳅𐳆𐳇𐳈𐳉𐳊𐳋𐳌𐳍𐳎𐳏𐳐𐳑𐳒𐳓𐳔𐳕𐳖𐳗𐳘𐳙𐳚𐳛𐳜𐳝𐳞𐳟𐳠𐳡𐳢𐳣𐳤𐳥𐳦𐳧𐳨𐳩𐳪𐳫𐳬𐳭𐳮𐳯𐳰𐳱𐳲𐳳𐳴𐳵𐳶𐳷𐳸𐳹𐳺𐳻𐳼𐳽𐳾𐳿𐴀𐴁𐴂𐴃𐴄𐴅𐴆𐴇𐴈𐴉𐴊𐴋𐴌𐴍𐴎𐴏𐴐𐴑𐴒𐴓𐴔𐴕𐴖𐴗𐴘𐴙𐴚𐴛𐴜𐴝𐴞𐴟𐴠𐴡𐴢𐴣𐴤𐴥𐴦𐴧𐴨𐴩𐴪𐴫𐴬𐴭𐴮𐴯𐴰𐴱𐴲𐴳𐴴𐴵𐴶𐴷𐴸𐴹𐴺𐴻𐴼𐴽𐴾𐴿𐵀𐵁𐵂𐵃𐵄𐵅𐵆𐵇𐵈𐵉𐵊𐵋𐵌𐵍𐵎𐵏𐵐𐵑𐵒𐵓𐵔𐵕𐵖𐵗𐵘𐵙𐵚𐵛𐵜𐵝𐵞𐵟𐵠𐵡𐵢𐵣𐵤𐵥𐵦𐵧𐵨𐵩𐵪𐵫𐵬𐵭𐵮𐵯𐵰𐵱𐵲𐵳𐵴𐵵𐵶𐵷𐵸𐵹𐵺𐵻𐵼𐵽𐵾𐵿𐶀𐶁𐶂𐶃𐶄𐶅𐶆𐶇𐶈𐶉𐶊𐶋𐶌𐶍𐶎𐶏𐶐𐶑𐶒𐶓𐶔𐶕𐶖𐶗𐶘𐶙𐶚𐶛𐶜𐶝𐶞𐶟𐶠𐶡𐶢𐶣𐶤𐶥𐶦𐶧𐶨𐶩𐶪𐶫𐶬𐶭𐶮𐶯𐶰𐶱𐶲𐶳𐶴𐶵𐶶𐶷𐶸𐶹𐶺𐶻𐶼𐶽𐶾𐶿𐷀𐷁𐷂𐷃𐷄𐷅𐷆𐷇𐷈𐷉𐷊𐷋𐷌𐷍𐷎𐷏𐷐𐷑𐷒𐷓𐷔𐷕𐷖𐷗𐷘𐷙𐷚𐷛𐷜𐷝𐷞𐷟𐷠𐷡𐷢𐷣𐷤𐷥𐷦𐷧𐷨𐷩𐷪𐷫𐷬𐷭𐷮𐷯𐷰𐷱𐷲𐷳𐷴𐷵𐷶𐷷𐷸𐷹𐷺𐷻𐷼𐷽𐷾𐷿𐸀𐸁𐸂𐸃𐸄𐸅𐸆𐸇𐸈𐸉𐸊𐸋𐸌𐸍𐸎𐸏𐸐𐸑𐸒𐸓𐸔𐸕𐸖𐸗𐸘𐸙𐸚𐸛𐸜𐸝𐸞𐸟𐸠𐸡𐸢𐸣𐸤𐸥𐸦𐸧𐸨𐸩𐸪𐸫𐸬𐸭𐸮𐸯𐸰𐸱𐸲𐸳𐸴𐸵𐸶𐸷𐸸𐸹𐸺𐸻𐸼𐸽𐸾𐸿𐹀𐹁𐹂𐹃𐹄𐹅𐹆𐹇𐹈𐹉𐹊𐹋𐹌𐹍𐹎𐹏𐹐𐹑𐹒𐹓𐹔𐹕𐹖𐹗𐹘𐹙𐹚𐹛𐹜𐹝𐹞𐹟𐹠𐹡𐹢𐹣𐹤𐹥𐹦𐹧𐹨𐹩𐹪𐹫𐹬𐹭𐹮𐹯𐹰𐹱𐹲𐹳𐹴𐹵𐹶𐹷𐹸𐹹𐹺𐹻𐹼𐹽𐹾𐹿𐺀𐺁𐺂𐺃𐺄𐺅𐺆𐺇𐺈𐺉𐺊𐺋𐺌𐺍𐺎𐺏𐺐𐺑𐺒𐺓𐺔𐺕𐺖𐺗𐺘𐺙𐺚𐺛𐺜𐺝𐺞𐺟𐺠𐺡𐺢𐺣𐺤𐺥𐺦𐺧𐺨𐺩𐺪𐺫𐺬𐺭𐺮𐺯𐺰𐺱𐺲𐺳𐺴𐺵𐺶𐺷𐺸𐺹𐺺𐺻𐺼𐺽𐺾𐺿𐻀𐻁𐻂𐻃𐻄𐻅𐻆𐻇𐻈𐻉𐻊𐻋𐻌𐻍𐻎𐻏𐻐𐻑𐻒𐻓𐻔𐻕𐻖𐻗𐻘𐻙𐻚𐻛𐻜𐻝𐻞𐻟𐻠𐻡𐻢𐻣𐻤𐻥𐻦𐻧𐻨𐻩𐻪𐻫𐻬𐻭𐻮𐻯𐻰𐻱𐻲𐻳𐻴𐻵𐻶𐻷𐻸𐻹𐻺𐻻𐻼𐻽𐻾𐻿𐼀𐼁𐼂𐼃𐼄𐼅𐼆𐼇𐼈𐼉𐼊𐼋𐼌𐼍𐼎𐼏𐼐𐼑𐼒𐼓𐼔𐼕𐼖𐼗𐼘𐼙𐼚𐼛𐼜𐼝𐼞𐼟𐼠𐼡𐼢𐼣𐼤𐼥𐼦𐼧𐼨𐼩𐼪𐼫𐼬𐼭𐼮𐼯𐼰𐼱𐼲𐼳𐼴𐼵𐼶𐼷𐼸𐼹𐼺𐼻𐼼𐼽𐼾𐼿𐽀𐽁𐽂𐽃𐽄𐽅𐽆𐽇𐽋𐽍𐽎𐽏𐽐𐽈𐽉𐽊𐽌𐽑𐽒𐽓𐽔𐽕𐽖𐽗𐽘𐽙𐽚𐽛𐽜𐽝𐽞𐽟𐽠𐽡𐽢𐽣𐽤𐽥𐽦𐽧𐽨𐽩𐽪𐽫𐽬𐽭𐽮𐽯𐽰𐽱𐽲𐽳𐽴𐽵𐽶𐽷𐽸𐽹𐽺𐽻𐽼𐽽𐽾𐽿𐾀𐾁𐾃𐾅𐾂𐾄𐾆𐾇𐾈𐾉𐾊𐾋𐾌𐾍𐾎𐾏𐾐𐾑𐾒𐾓𐾔𐾕𐾖𐾗𐾘

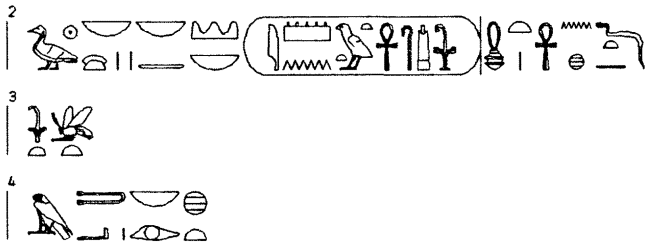

senkrechte Inschrift

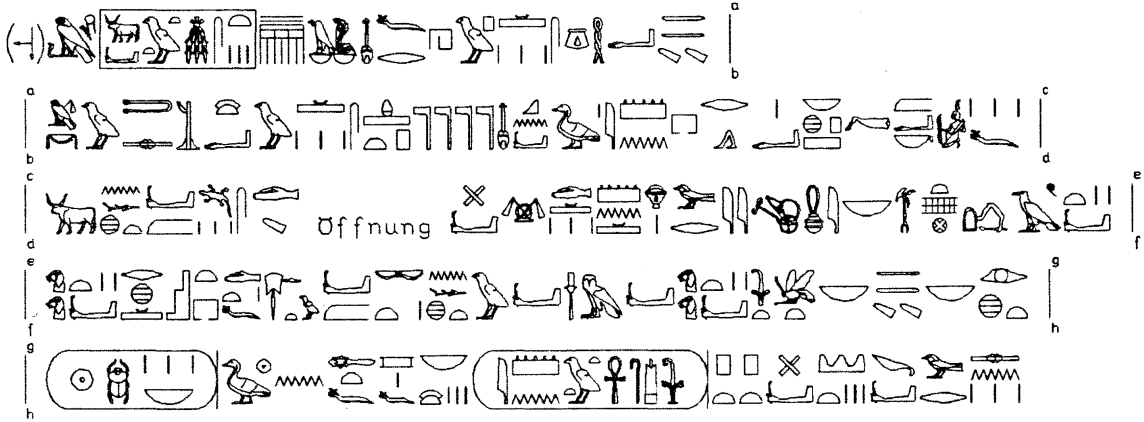

337a/61034 - Uschebti I



337a/61035 - Uschebti I



337a/61036 - Uschebti I



337a/61037 - Uschebti I



337a/61038 - Uschebti I



337b/61006 - Uschebti I



337b/61013 - Uschebti

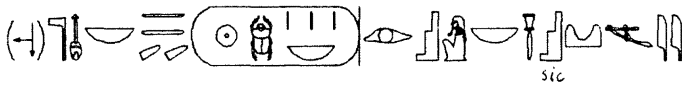

337c/60999 - Uschebti

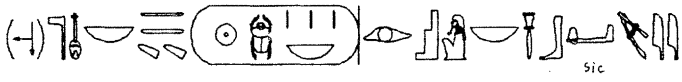

337c/61000 - Uschebti

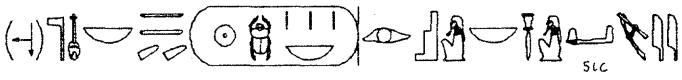

337c/61001 - Uschebti

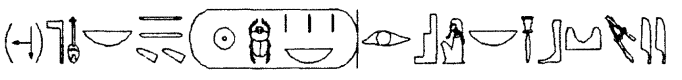

345 - Brettspiel

Textnachweis: TutTS 5, Taf.3-5.

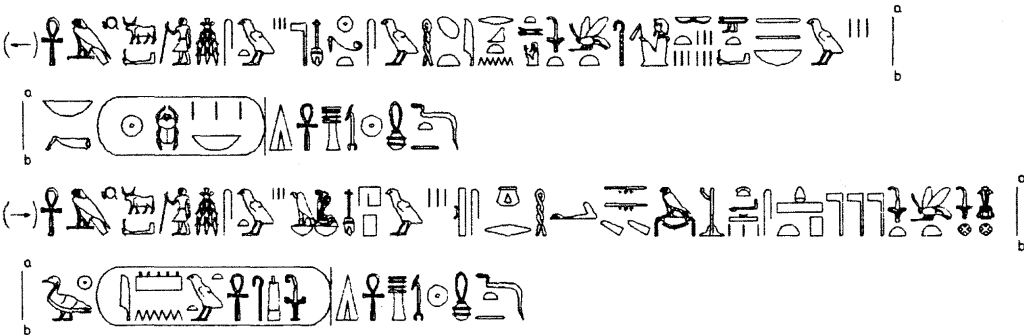

Vorderseite:

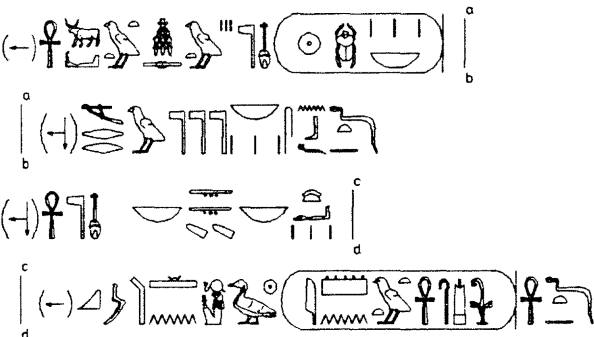

349 - Holzstuhl (Rücklehne)

Textnachweis: Brüssel/Wien, Nr.62; Deutschland (1976), Nr.60.

neben der geflügelten Sonnenscheibe links (-)  rechts (-) 

im Zentrum der Rücklehne:

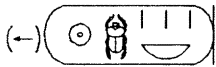

Inschrift links:

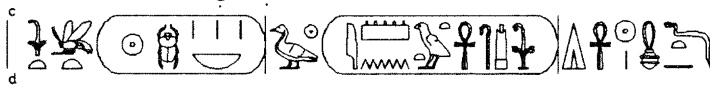
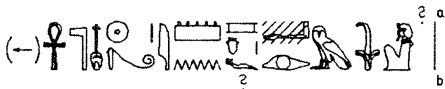

△ φ ι ε ρ ist als Spaltzeile geschrieben

Inschrift rechts:



Rückseite:

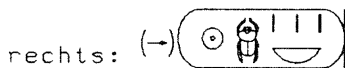

350 - Schild



351 - Priesterthron

Textnachweis: Seton-Williams, Abb.123; Edwards, S.224f.;

Fox, Schatz, Abb.68; Fox, Treasure, Abb. 60.

Vorderseite



Mittelzeile

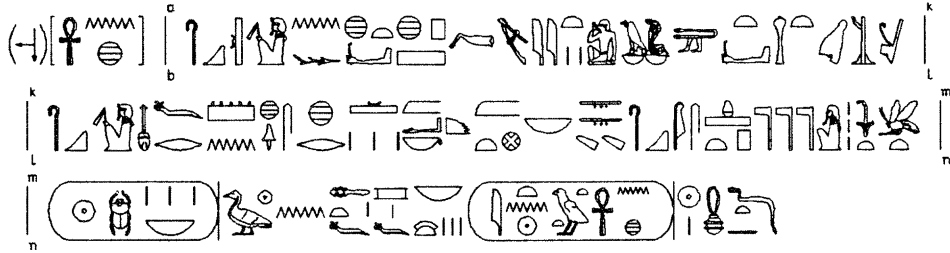

360 - Alabastervase

Textnachweis: David, Abb.70.

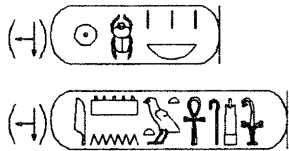

362 - Weinkrug

hieratische Inschrift TutTS 2, Nr.3

367d - Alabastervase

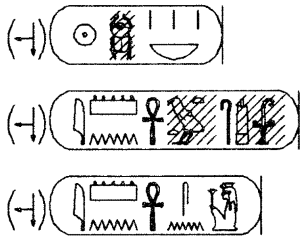

367l - Hemdbluse

mehrere kaum lesbare Kartuschen: (→)  und



geringe Reste der Titulatur u.a.: (→) 

367j - Hemdbluse

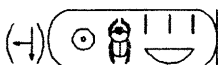

367k - Kartuschenförmige Holzschachtel



367l - Schreibpalette



367m - Schreibzeug-Behälter

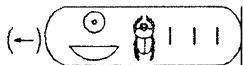

367o - Wurfholz

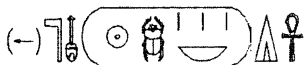

370a - sichelförmiger Stock (wohl zum Treiben von Rindern)



370l - sichelförmiger Stock, auf der Mitte des Stiels: 

370v - Bumerang

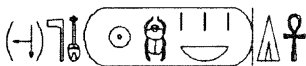

370gg - Bogen

Textnachweis: TutTS 3, Taf.9



370kk - Bogen

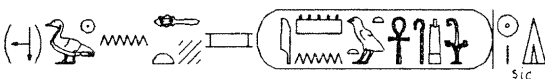

378 - Fuß-Stütze

Textnachweis: Seton-Williams, Abb.123.



392 - Weinkrug

hieratische Inschrift TutTS 2, Nr.5

Siegel



393 - Brettspiel-Kasten

Textnachweis: TutTS 7, Taf.8.

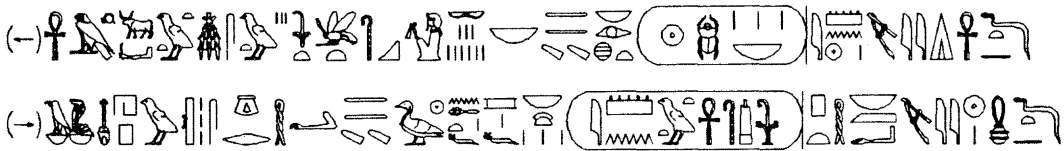

Oberseite:

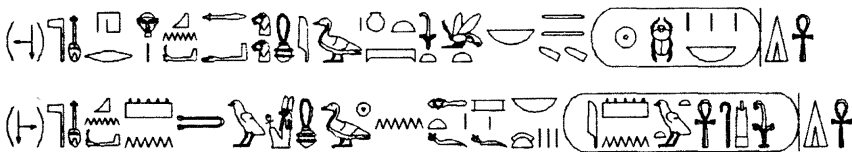

389 - Schreibbrett mit Goldauflage



399a - Fayence-Vase

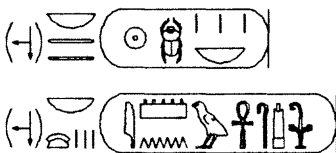

402 - Dächsel

auf dem Rücken des Griffes:



am Stielende:

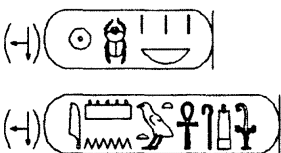

403 - Kasten

Textnachweis: Seton-Williams, Abb.131; London, Nr.15; UDSSR, Nr.50; Edwards, S.230.

Seite 1 (Vorderseite) linke Hälfte

oben

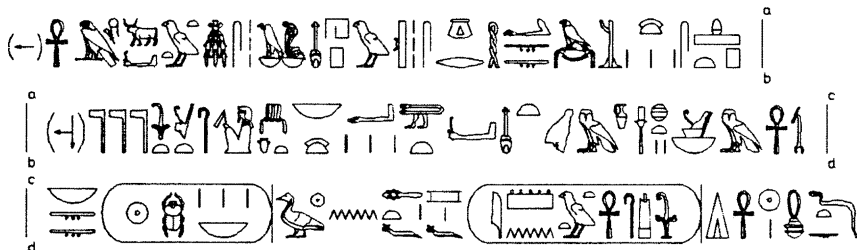

Mitte



unten

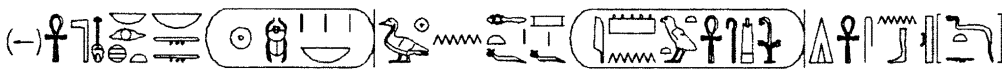

Seite 1 (Vorderseite) rechte Hälfte

oben



Mitte



unten



Seite 2 (rechte Seite)

unten



rechte Hälfte

oben

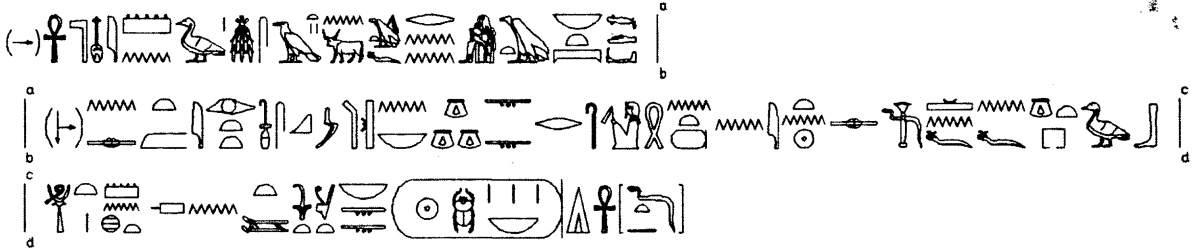

Mitte

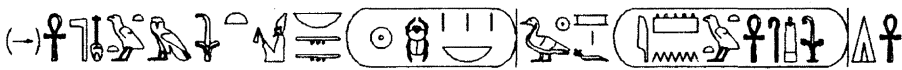

unten



Seite 4 (linke Seite)

linke Hälfte

oben

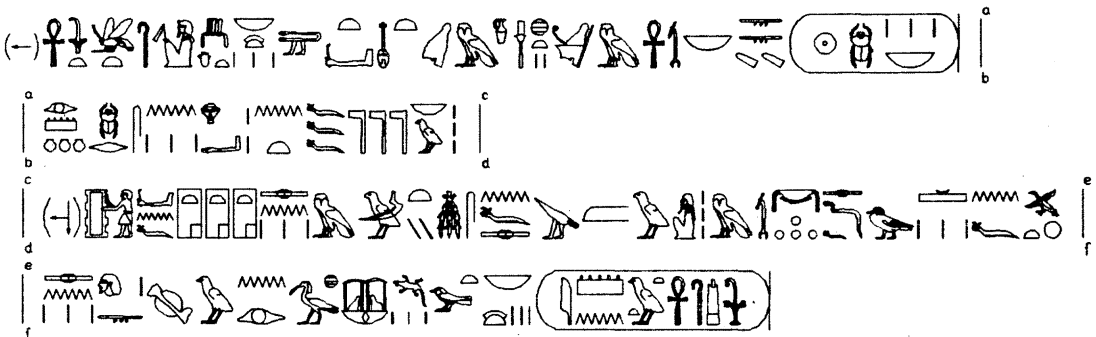

Mitte



unten

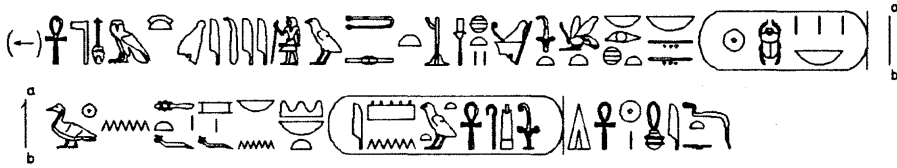

senkrechte Zeile rechts

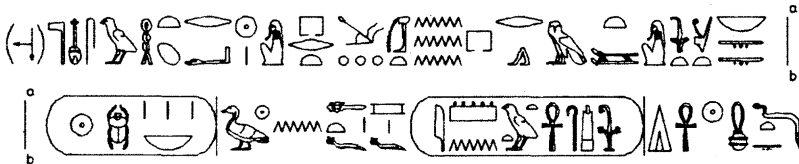

Deckel

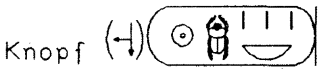

Mittelzeile

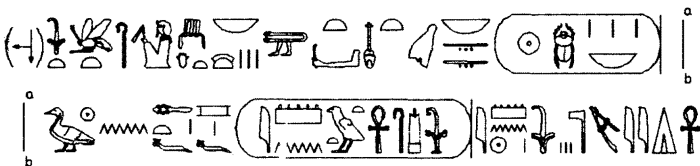

linke Seite

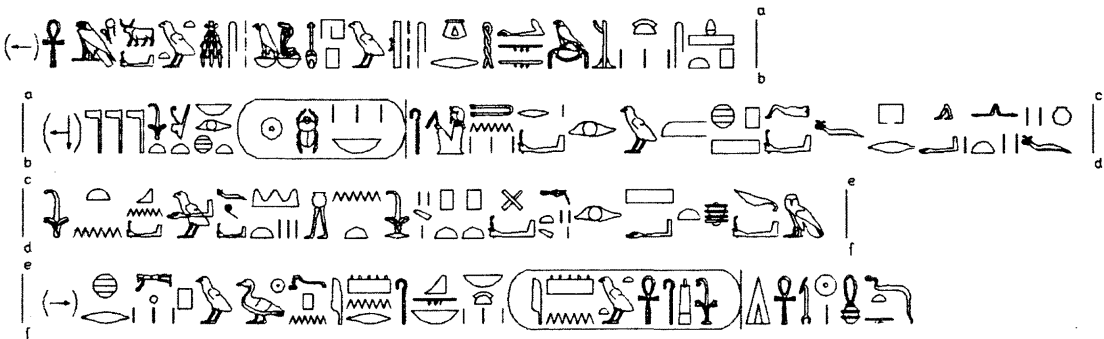

rechte Seite

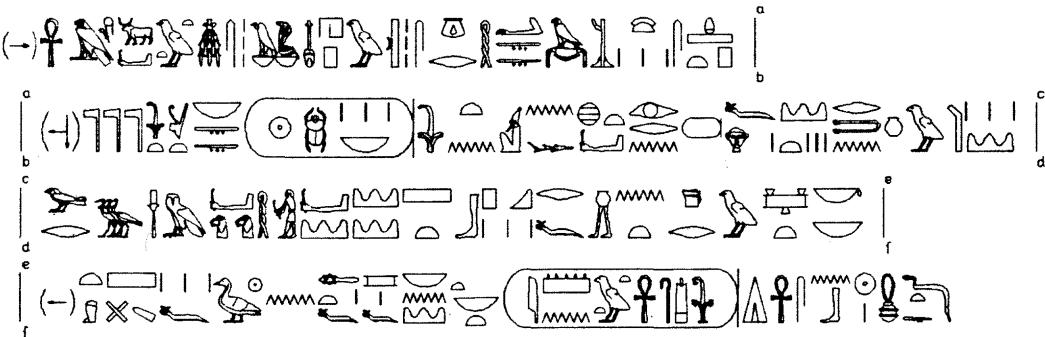

405 - Alabastervase

vier Kartuschen nebeneinander:

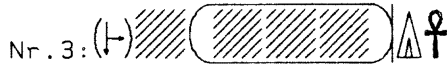
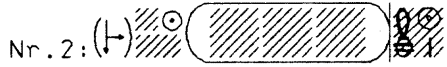
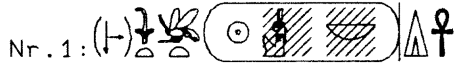

406 - Ton-Gefäß

hieratische Inschrift TutTS 2, Nr.38

410 - Alabaster-Vase

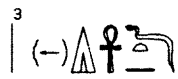
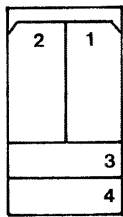

411 - Weinkrug

hieratische Inschrift TutTS 2, Nr.8

413 - Weinkrug

hieratische Inschrift TutTS 2, Nr.1

Siegel:



415 - Fächer



418a/60857 - Uschebti



418a/60859 - Uschebti



418a/60860 - Uschebti



418b ? /60873 - Uschebti



418b/60874 - Uschebti



418c/60902 - Uschebti



418d/60904 - Uschebti



418d/60933 - Uschebti



418d/60935 - Uschebti



418d/60936 - Uschebti



418e/60847 - Uschebti



418e/60848 - Uschebti



418e/60849 - Uschebti



418e ? /60850 - Uschebti



418f ? /60866 - Uschebti



418f ? /60867 - Uschebti



418f ? /60868 - Uschebti

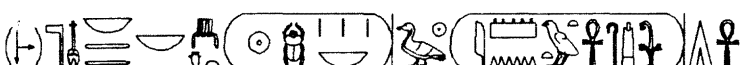

418g ? /60891 - Uschebti



418g ? /60903 - Uschebti



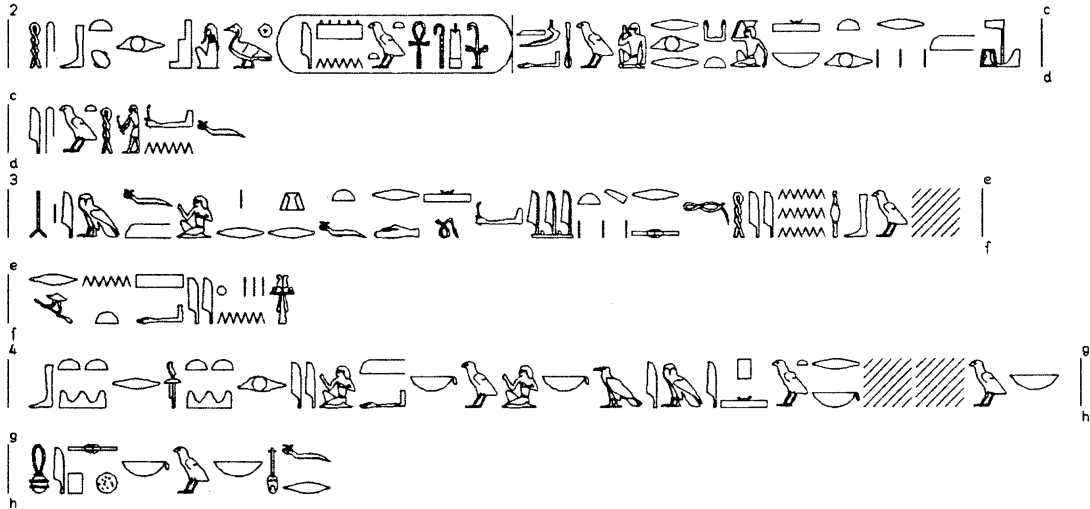

459a/60963 - Uschebti



459a ? /60964 - Uschebti



459a/60967 - Uschebti

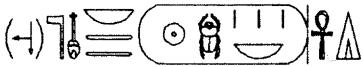

459b/60986 - Uschebti

Textnachweis: USA 61/63, Nr.25; Japan, Nr.24.



459c/60953 - Uschebti



459d/60983 - Uschebti



459d/60984 - Uschebti



459e ? /60950 - Uschebti

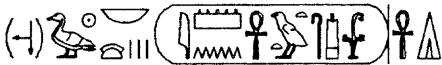

459e ? /60951 - Uschebti



459e/60952 - Uschebti



459e/60959 - Uschebti

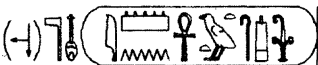

459e/60961 - Uschebti



459f/60971 - Uschebti



459f/60972 - Uschebti



459f/60973 - Uschebti



459f/60975 - Uschebti



459f/60976 - Uschebti



459f/60977 - Uschebti



468n - Stab



483 - Alabasterkrug mit Henkel

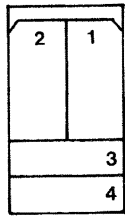
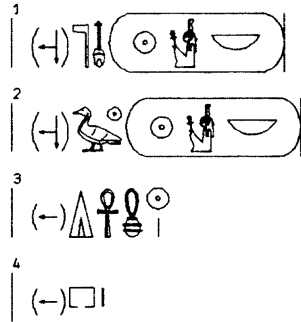

486 - Weinkrug

Siegel, Typ "DD"

hieratische Inschrift TutTS 2, Nr.2

487 - Schrein

an der Tür, schlecht lesbar:

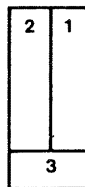

Seiten:

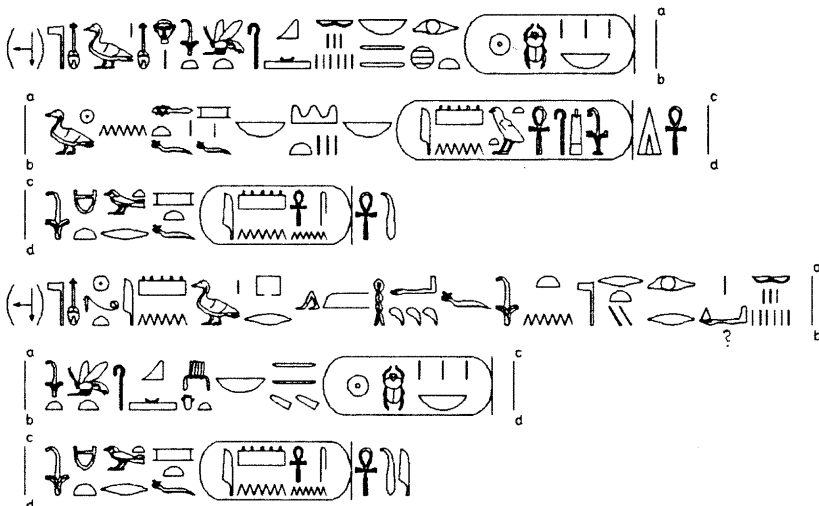

488a - Schild

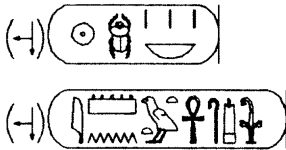

488b - Schild

rechts vor dem König:



unter dem Thron, zwischen zwei Rehit-Vögeln:

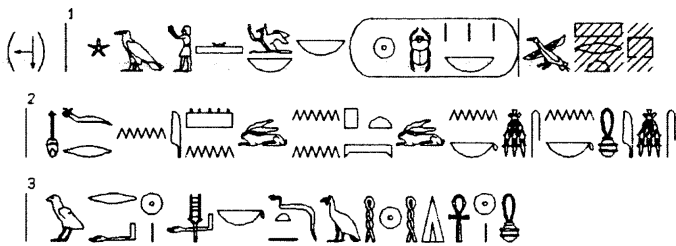

489 - Weinkrug

Siegel, Typ "BB"

hieratische Inschrift TutTS 2, Nr.11

490 - Weinkrug

hieratische Inschrift TutTS 2, Nr.26

492 - Schild

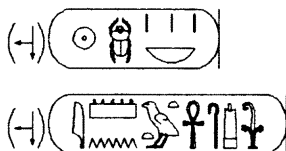

494 - Deckel eines Holzkastens

hieratische Inschrift TutTS 2, Nr.57

496a/60840 - Uschebti

Textnachweis: Fox, Schatz, Abb.61; Fox, Treasure, Abb.53;
Brüssel/Wien, Nr.60; Deutschland (1976), Nr.58.

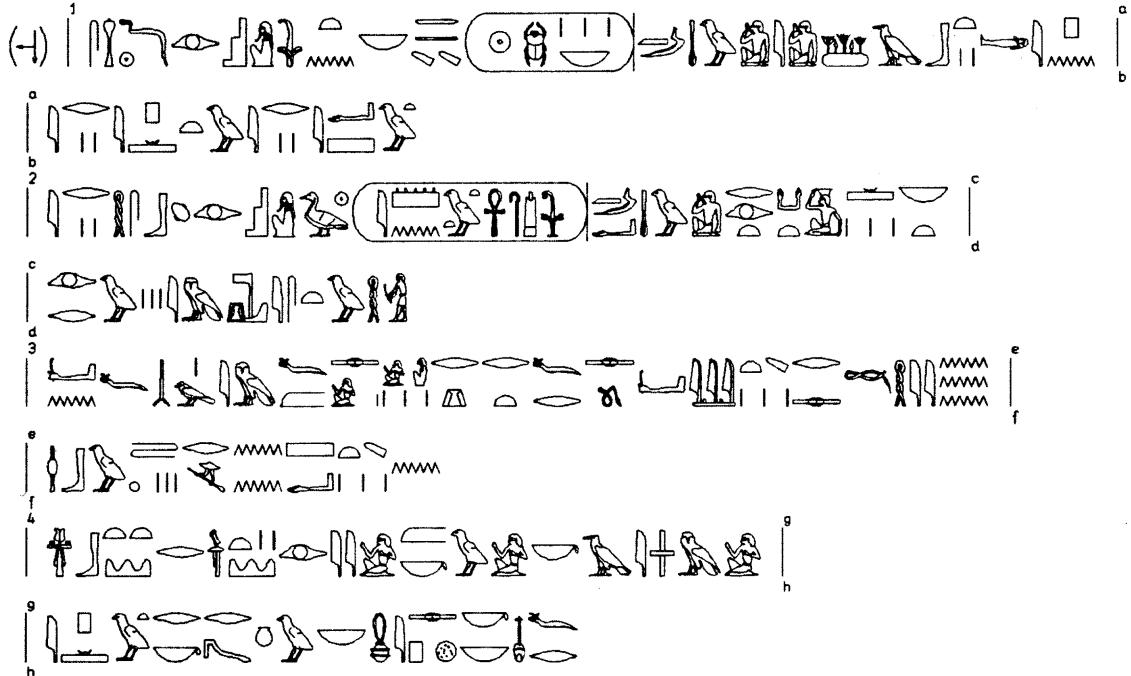

496b/60758 - Uschebti



496b/60759 - Uschebti



496b/60760 - Uschebti



496c ? /60766 - Uschebti



496c/60767 - Uschebti



496d/61108 - Uschebti



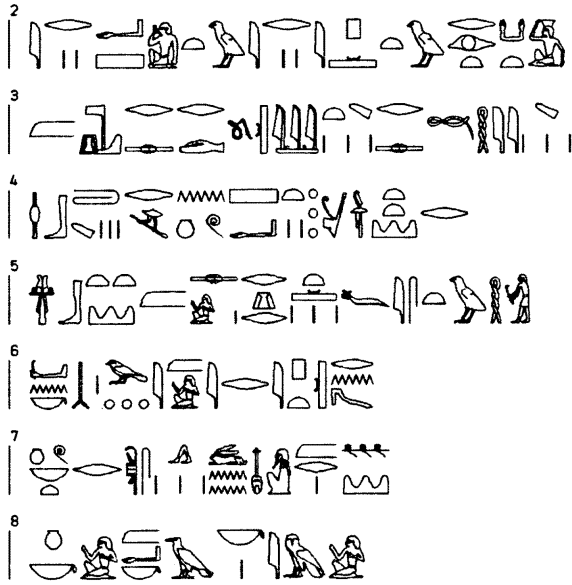

496d/61109 - Uschebti

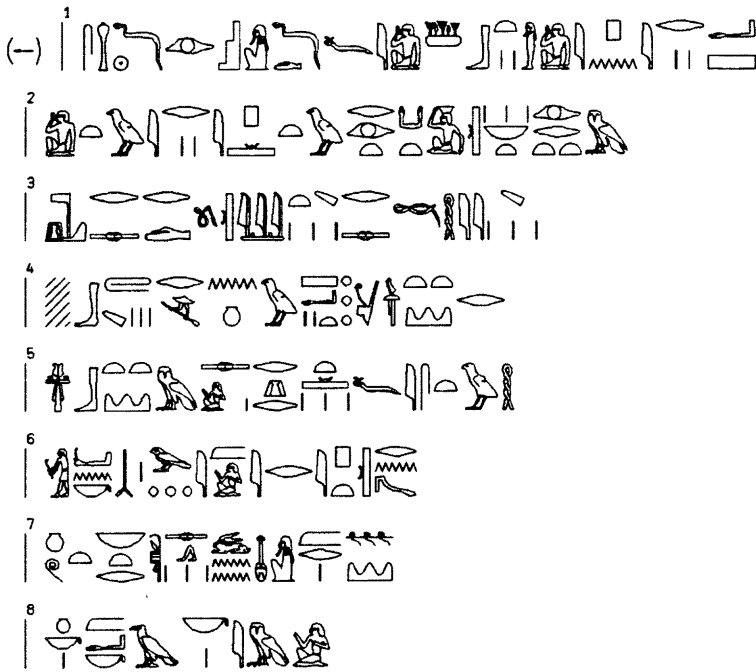

496d/61110 - Uschebti

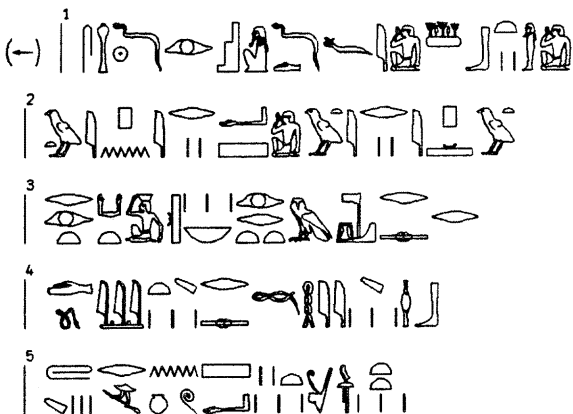

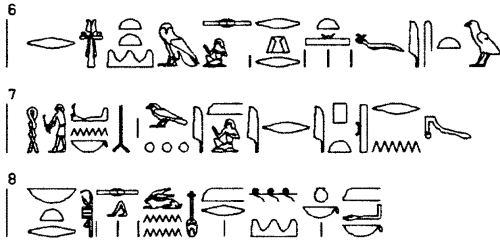

496e ? /61119 - Uschebti



496e/61139 - Uschebti



496e/61140 - Uschebti



496e/61141 - Uschebti



496e/61142 - Uschebti

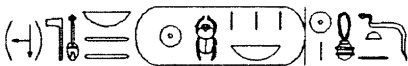

496e/61143 - Uschebti



496e ? /61152 - Uschebti

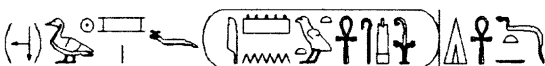

500 - Weinkrug

hieratische Inschrift TutTS 2, Nr.24

Siegel, Typ "MM"

508 - Weinkrug

hieratische Inschrift TutTS 2, Nr.16

512c/60800 - Uschebti



512c/60806 - Uschebti



512c/60807 - Uschebti



512c/60810 - Uschebti



512d/60768 - Uschebti



512d/60769 - Uschebti



512d/60771 - Uschebti



512e/60811 - Uschebti

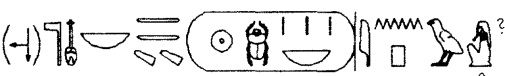

Faks.

512e/60812 - Uschebti

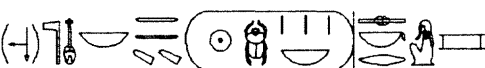

512e ? /60816 - Uschebti



512e/60817 - Uschebti



514a/61028 - Uschebti

Textnachweis: USA 61/63, Nr.26; Japan, Nr.23.

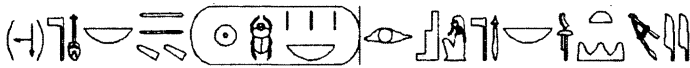

514a ? /61031 - Uschebti



514a ? /61032 - Uschebti



514a ? /61033 - Uschebti



514b/61016 - Uschebti



514b/61017 - Uschebti

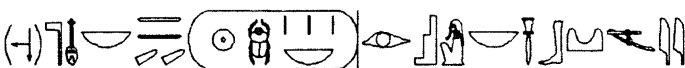

514b/61018 - Uschebti

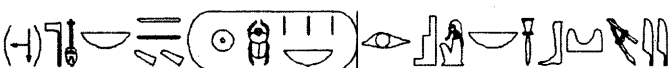

514c/60997 - Uschebti

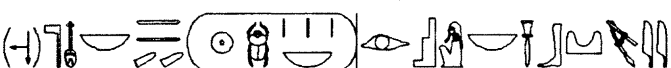

514c/60998 - Uschebti



514d/60996 - Uschebti



516 - Weinkrug

hieratische Inschrift TutTS 2, Nr.19

517a/60774 - Uschebti

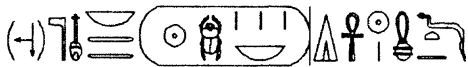

517a/60775 - Uschebti



517b/60778 - Uschebti

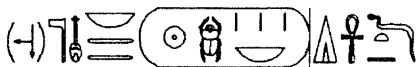

517b/60780 - Uschebti



517b/60781 - Uschebti



517c/60799 - Uschebti



517d ? /60777 - Uschebti

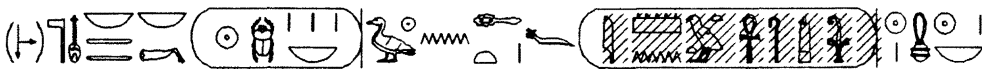

517d ? /60814 - Uschebti

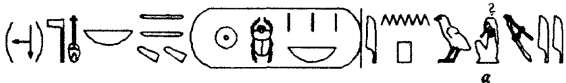

Faks. 

517e ? / 60886 - Uschebti



517e/60934 - Uschebti



517f ? / 60879 - Uschebti (evtl. 611b)



517f ? / 60893 - Uschebti (evtl. 611b)

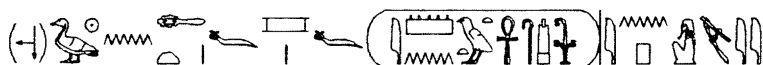

517g/60938 - Uschebti

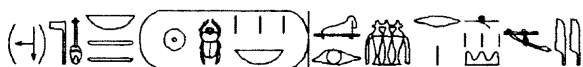

517h/60913 - Uschebti



517h/60920 - Uschebti

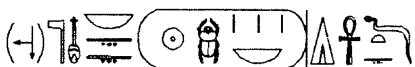

517h/60921 - Uschebti



517h/60922 - Uschebti

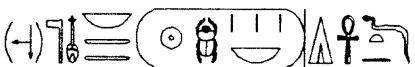

519a/61054 - Uschebti



519b/61095 - Uschebti



519c/61096 - Uschebti



519c/61097 - Uschebti



519c/61098 - Uschebti



519c/87852 - Uschebti



519d/61104 - Uschebti



519e/61160 - Uschebti

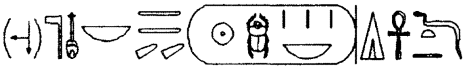

519e ? /61162 - Uschebti



519e/61163 - Uschebti



519e/61164 - Uschebti



519f/61161 - Uschebti



519f/61165 - Uschebti



519f/61166 - Uschebti

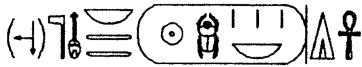

519f/61167 - Uschebti

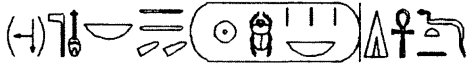

519f/61168 - Uschebti



520 - Alabaster-Vase

Textnachweis: David, Abb.71.

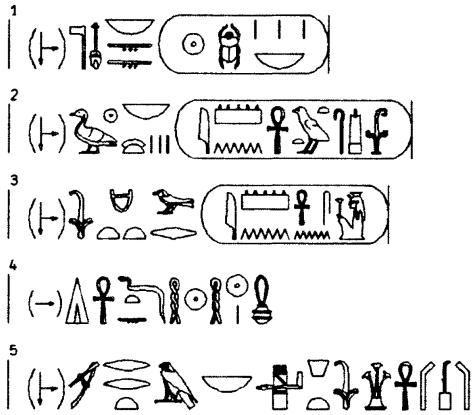

um die Schlange verteilt:



523 - Weinkrug

hieratische Inschrift TutTS 2, Nr.7

536 - Weinkrug

Siegel, Typ "00"

539 - Weinkrug

hieratische Inschrift TutTS 2, Nr.20

540, siehe 551

541 - Weinkrug

hieratische Inschrift TutTS 2, Nr.23

Siegel, ähnlich Typ "AA" oder "CC"

545 - Schild

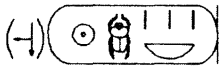

549 - Weinkrug

hieratische Inschrift TutTS 2, Nr.9

551 - Truhe, Deckel hat Nr.540

Textnachweis: Deutschland 80/81, Nr.35; Edwards, S.242ff.

Deckel:

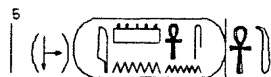
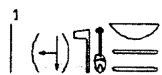

Truhe

vor dem König:

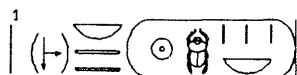

4	1	2
		3

vor der Königin:

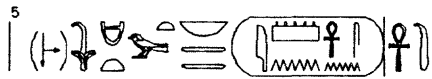

560 - Weinkrug

hieratische Inschrift TutTS 2, Nr.15

Siegel, Typ "CC"

561 - Sichel

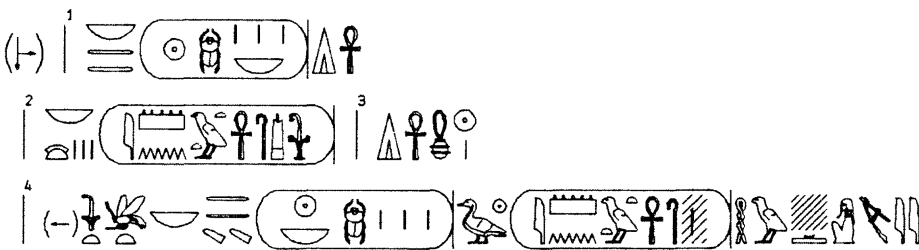

1	2
3	

563 - Weinkrug

hieratische Inschrift TutTS 2, Nr.25

566 - Schild

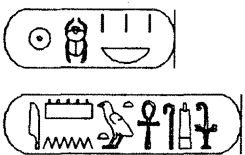

568 - Weinkrug

hieratische Inschrift TutTS 2, Nr.4

Siegel, Typ "LL"

570 - Weinkrug

hieratische Inschrift TutTS 2, Nr.17

571 - Weinkrug

hieratische Inschrift TutTS 2, Nr.12

Siegel, Typ "JJ" und "KK"

574 - Holzdeckel (zusammen mit 79, siehe dort)

575 - Holzdeckel

hieratische Inschrift TutTS 2, Nr.59

577 - Königsszepter

Textnachweis: Deutschland 80/81, Nr.48.



578 - Alabasterboot auf Ständer ("Tafelaufsatz")

Vorderseite

links: um Schlange mit o.äg.Krone verteilt:

rechts: um Schlange mit u.äg.Krone verteilt:

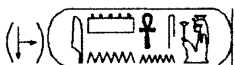
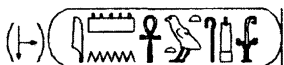

579 - Salbgefäß (Löwe)

Textnachweis: Edwards, S.216.

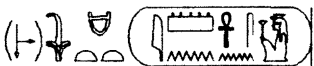
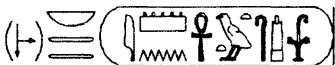

582b - Stab

oben an der Verzweigung:

unten:



³ | (-) Δ f i

⁴ | (-) f i () f i

596a - Fächer

vier Kartuschen:

Nr. 1 (-) (f i i i i i)

Auf der sonst fast identischen Rückseite fehlt das **f** beim

 des Kartuschenendes.

Nr. 2 (-) (i i i i i i i i)

Nr. 3 (-) (f i i i i i)

Nr. 4 (-) (f i i i i i)

unter den beiden Aton-Kartuschen:

(-) Δ f i i

statt **f i** steht auf der Rückseite des Fächers: **f i**

unter den beiden Echnaton-Kartuschen:

(-) Δ f i i

die Rückseite des Fächers ist fast völlig identisch mit der Vorderseite

598 - Teil eines Bootes (Kiosk von 437) *

vor der Sphinx: (-) f i () Δ f

599 - Fächer

(-) (i i i i)

600 - Fächer

(-) (i i i i)

602f/61073 - Uschebti



602f/61074 - Uschebti



602f/61075 - Uschebti



602f/61076 - Uschebti



602f/61077 - Uschebti

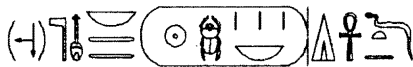

602f/61078 - Uschebti

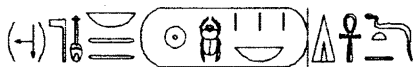

602f ? /61079 - Uschebti

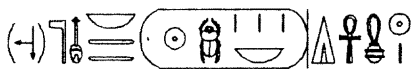

602f/61080 - Uschebti

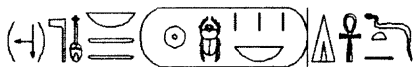

auf den Fußsohlen: 

602f/61081 - Uschebti

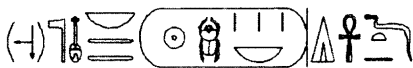

602f/61082 - Uschebti

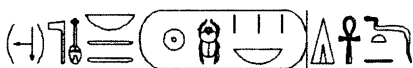

602f/61083 - Uschebti



602f/61084 - Uschebti



602f/61085 - Uschebti

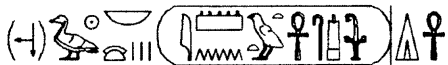

602f/61086 - Uschebti



602f/61087 - Uschebti

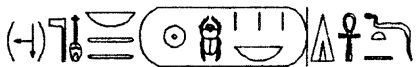

602f/61088 - Uschebti



602f/61089 - Uschebti

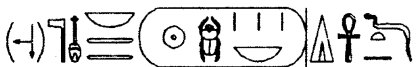

602f/61091 - Uschebti



602f/61092 - Uschebti



602f/61093 - Uschebti

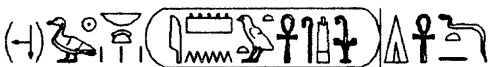

602f/61094 - Uschebti



602f/87853 - Uschebti



602f ? /87854 - Uschebti



605a/61043 - Uschebti



605b/61044 - Uschebti



605c/61020 - Uschebti



605c/61021 - Uschebti



605c/61022 - Uschebti



605d/61029 - Uschebti



605d/61030 - Uschebti



605e/61014 - Uschebti



605e/61015 - Uschebti



605f/61040 - Uschebti



605g ? /61002 - Uschebti



605g/61003 - Uschebti



605g ? /61004 - Uschebti

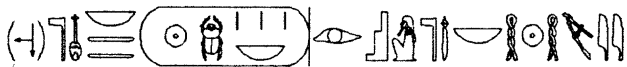

605g/61005 - Uschebti



607f - Bumerang

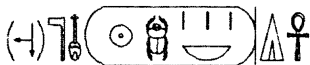

608a/60801 - Uschebti



608a/60802 - Uschebti



608a/60803 - Uschebti



608a/60804 - Uschebti



608a/60805 - Uschebti



608b/60795 - Uschebti



608b/60796 - Uschebti



608c/60789 - Uschebti



608c/60790 - Uschebti



608c ? /60791 - Uschebti



608c/60792 - Uschebti

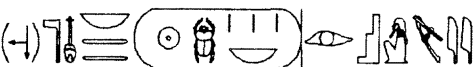

608c/60794 - Uschebti

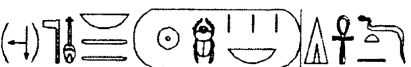

608c/60797 - Uschebti



608c/60798 - Uschebti

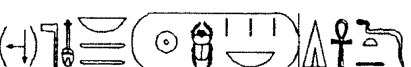

608c/60818 - Uschebti

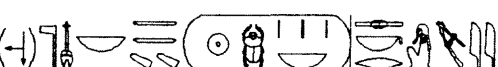

608c/60819 - Uschebti



608d/60776 - Uschebti



608d/60813 - Uschebti



608d/60815 - Uschebti



608e/60770 - Uschebti



608e/60772 - Uschebti



608e/60773 - Uschebti



611a ? /60882 - Uschebti



611a ? /60914 - Uschebti



611a ? /60915 - Uschebti



611a ? /60916 - Uschebti



611b ? /60877 - Uschebti



611b/60880 - Uschebti



611b ? /60883 - Uschebti



611b/60885 - Uschebti

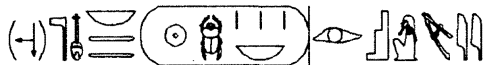

611b/60889 - Uschebti

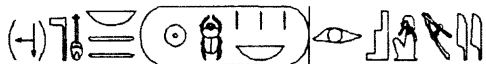

611b ? /60890 - Uschebti

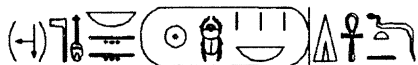

611b/60892 - Uschebti



611c/60876 - Uschebti



611c/60878 - Uschebti

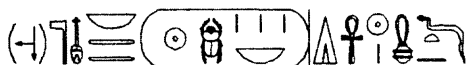

611c/60881 - Uschebti

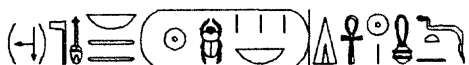

611c ? /60884 - Uschebti



611c ? /60887 - Uschebti



620 (32) - Hes-Vase



620 (33) - Libationsgefäß aus Fayence

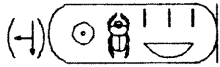

620 (40) - Arm-Reif aus Fayence



620 (41) - Arm-Reif aus Fayence

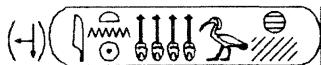

620 (42) - Arm-Reif aus Fayence

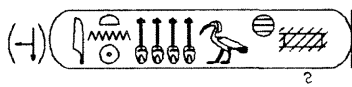
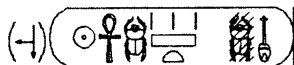

620 (43) - Armreif

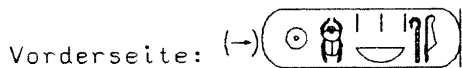

620 (56) - Griff eines Meißels

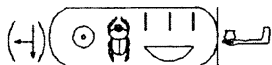

620 (58) - Werkzeug

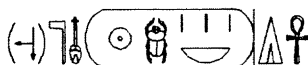

620 (66a-g) - Fayence-Ringe

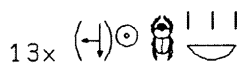



⌈ und ⌋ stehen rechts bzw. links von

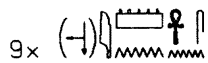
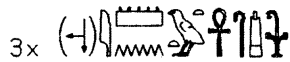

620 (67) - Herzgefäß mit Benu-Vogel auf Vorderseite

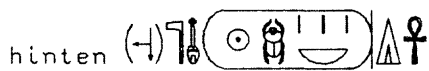

links neben der Kartusche ⌈, rechts: ⌋

620 (69) - Amulett, länglich-oval

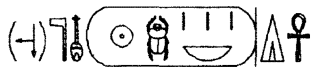

620 (70) - 4 Amulette (oval)



620 (72) - Papyrus-Amulett



620 (73) - Papyrus-Amulett



620 (76) - Amulett (oval)



620 (77) - Amulett (oval)

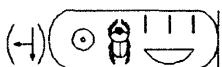

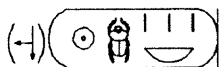
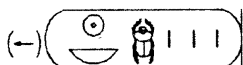
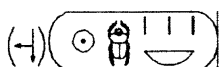
620 (78) - Amulett (oval)**620 (90) - Palette****620 (92) - Schreibzeug-Behälter****620 (95) - kleiner Kasten in Kartuschenform****620 (96-109) - Holztafeln**

hieratische Inschriften TutTS 2, Nr.63 bis 74, 76 und 77

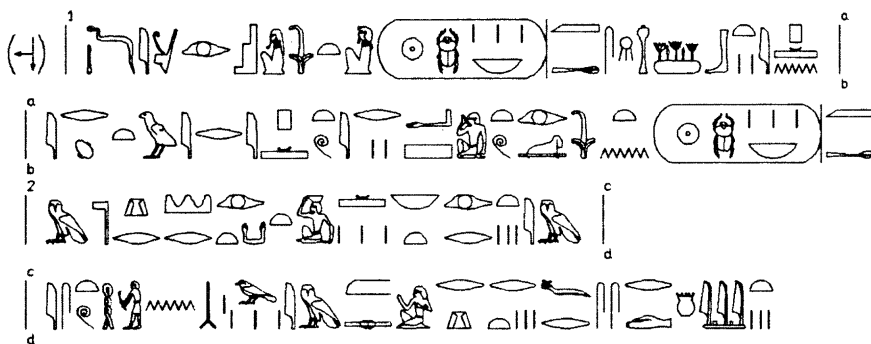
620 (113)/60832 - Uschebti**620 (116 bzw. 122) - Alabaster-Gefäß**

hieratische Inschrift TutTS 2, Nr.45

o.Nr. - Weinkrug

hieratische Inschrift TutTS 2, Nr.18

o.Nr. - Holztafel

hieratische Inschrift TutTS 2, Nr.62

o.Nr. - Holztafel

hieratische Inschrift TutTS 2, Nr.75

JE 87847 - Gürtelschnalle

Textnachweis: USA, Nr.6; Deutschland 80/81, Nr.14.

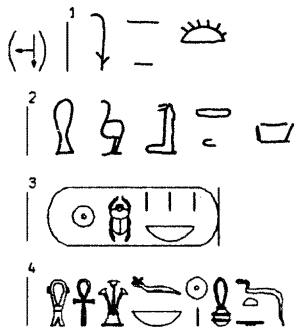

o.Nr. - Siegel (Streifunde)

Siegel, Typ "R" und "S"



Siegeltypen - Carter-Nummern

A	4	H	verloren	N	267, 268, 269, 270,
B	4	I	237a, 238a, 315		271, 272, 283, 320d
C	4	J	237a, 238a, 266b, 317	O	315
D	?	K	275, 279, 289, 320	P	178, 178a, 179
E	4	L	38a, 261	Q	304
F	?	M	271, 272	R	Streufund
G	?			S	Streufund

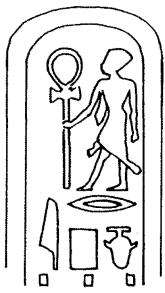

AA

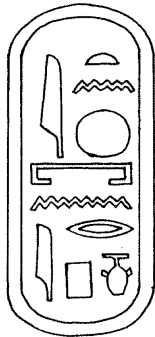

BB



CC

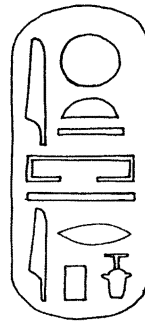

DD



EE



FF



GG

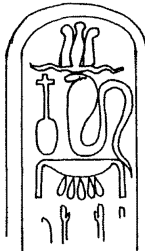

HH

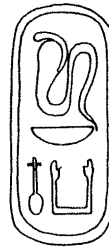

II

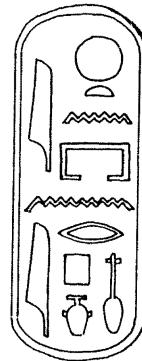

JJ



KK

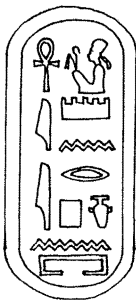

LL

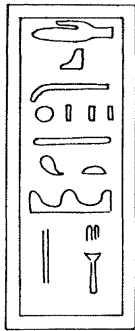

MM

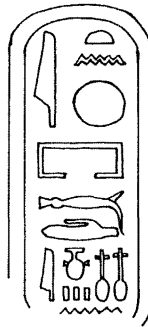

NN



OO

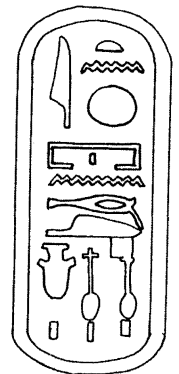

PP



Siegeltypen - Carter-Nummern

AA	432, 541 ?	FF	?	KK	571
BB	489	GG	?	LL	568
CC	508, 560, 541 ?	HH	?	MM	500
DD	486	II	?	NN	?
EE	?	JJ	434 ?, 571	OO	536

INDICES

(die Zahlenangaben beziehen sich auf die Carter-Nummern)

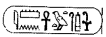
INDEX DER EIGENNAMEN

- Amenhotep III. 44p, 405, 483 (2mal), 588 (2mal)
 Anchesenamun 25, 32, 40, 53b, 79 (2mal), 79 (574)
 (2mal), 91, 101, 108 passim, 121 (2mal), 122 (4mal),
 122aa, 122z, 150 (5mal), 173, 210, 271 (8mal), 367d, 487
 (2mal), 520, 551 (2mal), 578, 579, 585r, 620 (66a-g)
 Anchesenpaaton 91
 Aton 91, 91, 256tttt, 291a, 300a, 351, 596a, 596a
 Echnaton 1k, 261a (? z. T. zerstört, aber wohl wegen der
 Jahresangabe nicht Semenchkare), 281a, 596 (2mal),
 620 (40)
 Eje Grab (Nordwand), Siegel 'S'
 Haremhab? Siegel 'Q'
 Maja 318b, 331a (2mal)
 Meretaton 1k, 46gg, 79 (574), 262 (2mal), 620 (13) (2mal)
 Nachtmin 318a, 318c, 330i, 330j, 330k
 Neferferure 54hh
 Nofretete 262
 Semenchkare 1k, 46gg, 48h (2mal), 79, 79 (574) (3mal),
 101s, 256a, 256b (2mal), 261a (?? wohl wegen der
 Jahresangabe Echnaton), 266g (14mal), 620 (41), 620 (42)
 Teje 44p, 320d (11mal), 588, 620 (13) (2mal)
 Thutmosis 333
 Thutmosis III. 404, 406, 585u
 Tutanchamun
 Horusname Grab (Nordwand), 14, 44 (2mal), 50 (2mal),
 54ddd, 54ddd (3), 87 (4mal), 101, 120 (2mal), 122 (2mal),
 122oooo (37) (?), 122oooo (46), 122y, 150 (4mal), 224,
 227a, 227c, 256qq, 268, 269 (5mal), 271 (7mal), 271e (2),
 335 (5mal), 345 (2mal), 388, 393, 403 (4mal), 585 (2mal)
 Nebti-Name 14, 87 (2mal), 122 (2mal), 122oooo (46), 150
 (4mal), 224, 227c, 269 (4mal), 271 (7mal), 335 (5mal),
 345, 393, 403 (4mal), 585 (2mal)
 Goldhorusname 14, 21, 87 (2mal), 122 (2mal), 150 (4mal),
 224, 227c, 269 (4mal), 271 (6mal), 335 (5mal), 345, 403
 (4mal), 585 (2mal)
- Nisut-Biti-Name passim
 Nisut-Biti-Kartuschen, die von der üblichen Form
 abweichen 22, 35, 44e, 48g (1) (2mal), 48h (2mal),
 48k (1) (4mal), 48q (2mal), 73, 108c, 122oooo (47), 137,
 153a, 227b, 227c (2mal), 227c, 240 (Seite D), 254 (2mal),
 256l, 256ee, 256oo, 256ss, 256vv, 256ooo, 256ooo, 261j,
 261p (3), 266b, 267k, 269m, 269o, 271b, 335 (4mal), 367l,
 367m, 561, 585 (2mal), 620 (43), 620 (90), Siegel 'R' ?
 Sa-Re-Name passim
 Schreibung: Amun-Anch-Tut:  21, 22, 32
 (4mal), 40 (2mal), 44a, 44w, 54k, 60, 79 (3mal), 100f
 (3mal), 108a, 150, 173 (2mal), 204 (2mal), 210 (3mal),
 211, 227c (2mal), 227e, 240, 240bis, 253, 254, 255, 255
 (TB 130), 256b (6mal), 256dd, 256qq, 261, 261i, 261m,
 261p (2), 266, 266g (Isis), 266g (Neith), 269d (2mal),
 269h, 319e/60928, 320, 325c/60764, 328c/60956,
 328d/60955, 328e ?/60965, 328h/60979, 328i/60980,
 328j/60981, 328m/60982, 337a/61038, 350, 367d (2mal),
 380d/60960, 380g/60974, 420 (2mal), 459a ?/60964,
 459c/60953, 459d/60983, 459d/60984, 459e ?/60950,
 459e ?/60951, 459e/60959, 459f/60975, 459f/60976,
 459f/60977, 459f ?/60978, 459g/60948, 496c ?/60766,
 520, 578, 579, 585r, 605g/61005, 619d
 Schreibung:  (mit umgedrehtem
 Schema-Zeichen) 40 (2mal), 54k, 210 (3mal), 211,
 328e ?/60965, 367d, 380g/60974, 459a ?/60964,
 459e ?/60950, 459e ?/60951, 459f/60975, 459g/60948,
 520, 578, 579
 Tutanchaton 48f (2mal), 48i (2), 48j (1), 48j (2), 91 (3mal),
 122bb, 122xx (?), 122yyy, 122zzz, 122eeee, 122ffff, 204,
 227b, 227c (?), 269f, 271e (2), 351 (8mal), 387 (?), 398,
 608b/60795
 Sa-Re-Kartuschen, die von der üblichen Form abweichen
 50xx (2mal), 60, 79 (2mal), 79 (574) (2mal), 91 (2mal),
 224, 261p (3), 266b, 269o, 351

INDEX DER GÖTTERNAMEN

- Aamemet 137
 Achi 87, 240, 256b (2mal), 266a (5mal), 266b (3mal), 266g
 (2mal), 280a, 317a, 317a (1), 317b, 317b (1), 320, 331a
 Amun 3, 10, 21, 47, 48f (2mal), 48j (1), 50ss, 50xx, 87
 (2mal), 101p, 108 (2mal), 121, 150, 204 (3mal), 224,
 227c, 227e, 266, 269, 269b (2mal), 271a, 335, 349, 367i,
 403 (4mal), 403c, 420, 487, 488b, 577, 582c, 585, 585g,
 585r (2mal)
 Amun-Re 14, 21ff, 44f, 50, 50gg, 50nn, 54k, 101p, 175,
 256ff, 256ooo (2mal), 271b, 393, 403
 Anubis 32, 194, 202, 240 (2mal), 254 (3mal), 255 (3mal),
 256a (2mal), 256b (3mal), 261 (8mal), 266 (5mal), 266a

- (2mal), 317a (2mal), 317a (1)(2mal), 317b (2mal), 317b (1) (2mal), 319j/60941, 319l/60943, 320, 324l/60910, 324o/60912, 324p/60917, 331a (2mal), 512e/60811, 517d/60814, 517ff/60879, 517ff/60893, 608b/60795, 608b/60796, 608d/60813, Grabwand
- Aton 3, 10, 91 (2mal), 195, 204, 261m (2mal), 281a, 291a, 300a, 351, 403 (3mal), 577, 585r, 596a, 620 (13), 620 (40)
- Atum 32 (2mal), 44a, 44gg, 44o, 54k, 87 (2mal), 108, 242, 255, 256b, 266, 266a, 269, 269b, 271b, 290a, 345, 349, 403 (4mal)
- Ba-des-Re 255
- Bastet 242
- Bau v, Heliopolis 87, 403 (2mal), 585
- Behedet 21, 120, 240, 349 (2mal)
- Benu 256a, 256q
- Chepre 256rrr, 266, 266g, 269, 269b, 297a, 403, 585
- Descheret-Krone 403, 585
- Duamutef 240, 256b, 266a (5mal), 266b, 266g (2mal), 302a, 317a, 317a (1), 317b, 317b (1), 320, 331a
- Geb 32 (3mal), 240 (2mal), 254, 255 (3mal), 256b (2mal), 261n, 266 (2mal), 266a (2mal), 266g (4mal), 299a, 317a, 317a (1) (2mal), 317b, 317b (1) (2mal), 403
- Gemehsu 283c
- Götterneunheit 32 (3mal), 240, 255, 256a (2mal), 256b, 261, 266g, 585 (2mal)
- Hapi 240, 256b (2mal), 266a (5mal), 266b (3mal), 266g (2mal), 301a, 317a, 317a (1), 317b, 317b (1), 320, 331a
- Hapi (Nil) 351
- Harachte 25, 87, 242, 253, 256b, 256tttt, 269b, 300a, 335
- Harendotes 32, 253, 254 (2mal), 266a, 317a (2mal), 317a (1), 317b, 317b (1), 320
- Har(endotes) 320
- Harocris 293a
- Hathor Grabwand
- Hedjet-Krone 403, 585
- Herr-von-Theben 335
- Herui 32
- Horus 32, 47, 87, 108, 210, 240, 253 (2mal), 254 (2mal), 255 (7mal), 256a (2mal), 256b (?), 266a (2mal), 266b, 266g (8x), 269b, 271a, 317a (1), 317b (1) (2mal), 331a, 420, 520
- Horus-Chenti-Chem 298a
- Horus-Tatenen 351
- Hu 561
- Isis 240 (2mal), 253 (3mal), 254 (3mal), 255 (2mal), 261i, 261m (2mal), 261o, 266 (2mal), 266a (2mal), 266b (3mal), 266g (3mal), 295a, 317a (1), 317b (1), 320a, 512e/60816, 608d/60815, Grabwand
- Ius-aes 54k
- Kamutef 403
- Kebehseuef 240, 256b, 266a (4mal), 266b, 266g (2mal), 317a, 317a (1), 317b, 317b (1), 320, 331a
- Maat 32, 122oooo (3), 122oooo (8), 122oooo (15), 122oooo (34), 150, 266g, 267q
- Mamu 281a
- Mehit (?) 35, 73
- Menkaret 74, 296a
- Month 50pp, 50xx, 121 (2mal), 150, 224, 266, 335, 379a, 379b, 393
- Mut 108, 403
- Neb-er-djer 32, 266, 403
- Nebti 351 (3mal)
- Nehebkau 256b
- Neith 240, 266a (2mal), 266b (2mal), 266g (2mal), 578
- Neper 351
- Nephthys 240, 253, 261i, 261m (2mal), 261o, 266, 266a (2mal), 266b (3mal), 266g (4mal), 305a
- Netjer-anch 283a
- Nil 351
- Nut 32, 253 (2mal), 254 (3mal), 255 (3mal), 256b, 261p (1)fs5(2mal), 261p (3), 266 (2mal), 266a, 266g (4mal), 317a (2mal), 317a (1) (2mal), 317b, 317b (1) (2mal), 320, 320a, 331a, Grabwand
- Osiris 32, 101w, 240 (3mal), 253, 254 (7mal), 255, 256b, 256n, 261m, 261m, 261n, 266 (15mal), 266g (6mal), 317a, 317a (1) (3mal), 317b (3mal), 317b (1) (3mal), 319a/60944, 319b/60945, 319d/60929, 319h/60939, 319i/60940, 319k/60942, 319o/60907, 320a, 320a, 322a/61023, 322b/61007, 322c/61008, 322d/61009, 322e/60990, 322f/60991, 322g/61041, 322h/61042, 323c/60863, 324e/60925, 324i/60906, 324n/60911, 324s/60931, 324i/60932, 325e ?/60779, 327ee/61112, 327ff/61113, 327gg/61114, 327h/61105, 327i/61106, 327j/61105, 327jj/61116, 327k/61111, 329a/60992, 329b/60993, 329c/60994, 329d/60995, 329e/61010, 329f/61011, 329g/61012, 329h/61024, 329i/61025, 329j/61026, 329k/61027, 330l/61049, 330m/61050, 330n/61046, 331a/60720, 337a/61034, 337a/61035, 337a/61036, 337a/61037, 337a/61038, 337b/61006, 337b/61013, 337c/60999, 337c/61000, 337c/61001, 496d/61108, 496d/61109, 496d/61110, 512b/60793, 512c/60810, 514a/61028, 514a/61031, 514a/61032, 514a/61033, 514b/61016, 514b/61017, 514b/61018, 514c/60997, 514c/60998, 514d/60996, 517e/60886, 517g/60938, 605d/61029, 605d/61030, 605e/61014, 605e/61015, 605f/61040, 605g/61002, 605g/61003, 605g/61004, 605g/61005, 608a/60801, 608c/60789, 608c/60791, 608c/60792, 608c/60819, 611b/60877, 611b/60883, 611b/60885, 611b/60889, 611c/60884, 611c/60937, Grabwand
- Peri-her-senef 176
- Ptah 21gg, 32, 44l, 50, 50gg, 53b, 108 (2mal), 122aa, 175, 261n, 267q, 271a, 291a, 393, 551, 585, 620 (66a-g) (Ptah) 87 (3mal), 101, 269b (2mal), 487, 585 (2mal)
- Ptah-Sokar 253, 255, 256a (2mal)
- Ptah-Sokar-Osiris 32, 255, 266a, 320d, 517e/60934
- Re 21, 21, 32 (7mal), 47 (2mal), 50ss, 87 (2mal), 122, 240 (7mal), 242, 253, 255 (mal), 256b (5mal), 256g, 261, 261m (4mal), 266 (2mal), 266a (2mal), 266g (13mal), 269b, 335, 345, 349 (2mal), 403 (3mal), 420, 488b, 585 (2mal)
- Re-Atum 403 (2mal)
- Re-Harachte 32, 44gg, 44o, 50, 50gg, 87, 175, 256b, 255, 256rrr, 335, 403
- Re-Harachte-Atum 32
- Sachmet 108 (2mal), 267q, 271a (2mal), 300a, 585
- Schedet (?) 35, 73
- Schu 32, 254, 255, 256tttt, 266g (2mal), 281a, 282a, 291a, 300a
- Selket 240, 266b (2mal), 266g (2mal)
- Sendet 294a
- Seschet 38b
- Seth 256a, 266g
- Sohn der Nut 21, 48g (2), 121, 150, 266, 269, 379a, 393
- Sokar 255, 269b, 323o/60930, 324f/60926, 324g/60898, 324h/60905, 418a/60857, 418e/60847, 512e/60812, 517c/60799, 608c/60818
- Sokar-Osiris 23l/60852, 323m/60853, 323n/60851, 418e/60848, 418e/60849
- Sopdu 283b
- Tata 303a
- Tatenen 292a
- Tefnut 254, 266g
- Thot 32, 32, 87, 240, 240, 255 (4mal), 256a, 256ff, 266g (6mal), 271b (2mal), 271e (2), 512e/60817
- Wadjet 210, 578
- Wennefer 5c, 32 (3mal), 240, 255 (3mal), 256b, 261p (1), 266g, 318b/60826, 320d
- Wenti 266g
- Weret-hekau 108 (10mal), 108a, 256qq

ABSCHNITTE AUS GRÖßEREN TEXTZUSAMMENHÄNGEN

Totenbuch

TB 1	Carter Nr. 266g
TB 1	Piankoff Pl. IV
TB 1	Piankoff Pl. XV
TB 1	Piankoff S. 14
TB 1	Piankoff S. 43
TB 6	Carter Nr. 110
TB 6	Carter Nr. 318a
TB 6	Carter Nr. 318b
TB 6	Carter Nr. 318c
TB 6	Carter Nr. 325a
TB 6	Carter Nr. 325b
TB 6	Carter Nr. 326a
TB 6	Carter Nr. 327h
TB 6	Carter Nr. 327i
TB 6	Carter Nr. 327j
TB 6	Carter Nr. 327k
TB 6	Carter Nr. 330a
TB 6	Carter Nr. 330b?
TB 6	Carter Nr. 330c
TB 6	Carter Nr. 330d?
TB 6	Carter Nr. 330e
TB 6	Carter Nr. 330f
TB 6	Carter Nr. 330g
TB 6	Carter Nr. 330h
TB 6	Carter Nr. 330i
TB 6	Carter Nr. 330j
TB 6	Carter Nr. 330k
TB 6	Carter Nr. 458
TB 6	Carter Nr. 496d/61108
TB 6	Carter Nr. 496d/61109
TB 6	Carter Nr. 49d/61110
TB 6	Carter Nr. 601
TB 6	Carter Nr. 620 (113)
TB 17	Carter Nr. 255
TB 17	Piankoff Pl. IV
TB 17	Piankoff S. 54
TB 17	Piankoff S. 73 ff.
TB 26	Carter Nr. 255
TB 26	Carter Nr. 261n
TB 26	Piankoff Pl. IV
TB 27	Carter Nr. 255
TB 27	Carter Nr. 261j
TB 27	Piankoff Pl. IV
TB 29	Piankoff Pl. IV
TB 29 B	Carter Nr. 256q
TB 30 A	Carter Nr. 256b
TB 30 B	Carter Nr. 261m

TB 130	Carter Nr. 255
TB 130	Carter Nr. 266g
TB 130	Piankoff S. 51 ff.
TB 133	Piankoff S. 59
TB 134	Carter Nr. 266g
TB 134	Piankoff S. 15
TB 134	Piankoff S. 58 f.
TB 136 A	Carter Nr. 266g
TB 141/142	Piankoff S. 20 f.
TB 141/142	Piankoff S. 50 f.
TB 144	Piankoff S. 45 ff.
TB 147	Piankoff Pl. V
TB 147	Piankoff Pl. VII
TB 148	Piankoff S. 55 ff.
TB 151 (2mal)	Carter Nr. 255
TB 151	Carter Nr. 256a
TB 151	Carter Nr. 257
TB 151	Carter Nr. 259
TB 151	Carter Nr. 260
TB 151	Carter Nr. 263
TB 155	Carter Nr. 256kk
TB 159	Piankoff Pl. IV
TB 166	Carter Nr. 255

Sargtexte

Spruch 387	Carter Nr. 256b
------------	-----------------

Amduat

1. Stunde	Grab, Westwand
2. Stunde	Piankoff Pl. 6
6. Stunde	Piankoff Pl. 8

Unterweltbuch (vgl. Hornung, *JSSEA*
13, 1 [1983] 29 ff.)

Piankoff Pl. 2, 4

Kuh-Buch

Piankoff Pl. 1, S. 18

INDEX DER STICHWORTE

Äußerer Schrein 207
 Äußerer Sarg 253
 Alabaster-Boot ('Tafelaufsatz') 578
 Alabaster-Gefäß 7, 7a, 7b, 20, 32b, 55, 57, 385,
 620 (116 bzw. 122)
 Alabaster-Kanne 588
 Alabaster-Kelch 14

Alabaster-Krug 483
 Alabaster-Schrein 266b
 Alabaster-Truhe 40, 61, 173, 404, 410, 420, 520
 Alabaster-Vase 127, 360, 367d, 405
 Amset-Figur 280a
 Amulett (Anch) 99a, 620 (24)
 Amulett (Djed) 256kk, 587b, 587d, 620 (21)

- Amulett (Isis-Blut) 46y, 620 (18)
 Amulett (oval) 620 (69), 620 (70), 620 (76), 620 (77),
 620 (78)
 Amulett (Papyrus) 620 (72), 620 (73)
 Amulett (Schlangenkopf) 138
 Amulett (Was) 620 (15)
 Anubis-Schrein 261
 Armband 256oo, 256qq, 256ss, 256aaa, 269g, 269m
 Armreif 256n, 256hh (3), 585q, 620 (40), 620 (41), 620 (42),
 620 (43)
 Atum-Figur 290a

 Blattgoldstücke 122 . . .
 Bogen 48f, 48g (1), 48g (2), 48h, 48i (1), 48i (2), 48j (1),
 48j (2), 48k (1), 48k (2), 48l, 77b, 135z, 153, 370gg, 370kk
 Bogenkasten 335
 Boot 273, 276, 285, 286, 307, 311, 598
 Brettspiel 345, 393, 585r
 Bumerang 370v, 607f, 620 (4), 620 (5), 620 (6)

 Chenti-Chem-Figur 298a
 Chepre-Figur 297a

 Dächsel 44p, 402
 Deckel eines Holzkastens 54hh, 270b, 494
 Dolch 256dd
 Duamutef-Figur 302a

 Ebenholz-Liege 47
 Elfenbein-Griff 54ddd (3)

 Fächer 242, 245, 272a, 389, 415, 596a, 599, 600
 Fayence-Becher 54rr
 Fayence-Gefäß 25, 54t, 54z, 54aa, 54bbb, 620 (33)
 Fayence-Napf 54u
 Fayence-Ring 153a, 620 (66a-g)
 Fayence-Schale 54n
 Fayence-Vase 31, 31a, 54w, 54ccc, 63, 399a, 620 (29),
 620 (30)
 Fingerringe 256ff, 256vv
 Flagellum 269f
 Fuß-Schemel 88, 90, 378

 Gürtel 256l, 256ee
 Gürtelschnalle JE 87847
 Geb-Figur 299a
 Gebogener Stock 48a, 48b, 48c, 48d
 Gegengewicht 267b
 Gemehsu-Figur 283c
 Gewand 44w, 101p
 Gold-Plättchen 46gg
 Goldbeschlag von Gürtel 585s
 Goldkragen 256p
 Goldmaske 256a
 Goldsarg 255
 Goldschrein 108
 Goldspangen 44a
 Goldstatuette 235a
 Griff eines Meißels 620 (56)

 Halskragen 46b
 Hals schmuck 256rrr
 Handschutz von einem Kampfstock 619b, 619d
 Hapi-Figur 301a
 Haroeris-Figur 293a
 Heka-Szepter 269d, 269h
 Hemdbluse 367i, 367j
 Herzgefäß 620 (67)
 Hes-Vase 620 (31), 620 (32)

 Hieratisch 1k, 1l, 7, 7a, 7b, 11, 20, 21n, 32b, 54, 54ddd, 55,
 62a-vv, 68, 79, 91, 101, 101x, 180, 195, 206, 256p, 267,
 268, 270b, 272, 283, 330, 362, 386, 392, 406, 411, 413,
 434, 486, 489, 490, 494, 500, 508, 509, 516, 523, 539,
 541, 549, 560, 563, 568, 570, 571, 575, 614a-k, 615,
 620 (96-109), 620 (116 bzw. 122), o. Nr., o. Nr.,
 o. Nr.
 Holz-Brett 101x, 386
 Holz-Gans 176
 Holzdeckel 574, 575, 615
 Holzkästen für Nahrung 62a-vv
 Holzkasten 1k, 1l, 14b, 50, 54, 68, 79, 267, 268, 269, 272,
 283, 330, 367k, 388, 403, 620 (95)
 Holzschale 44s
 Holzstreifen von einem Wagen 150
 Holzstuhl (Rücklehne) 349
 Holztafel 21n, 620 (96-109), o. Nr., o. Nr.
 Holztruhe mit Satteldach 32

 Imiut 194, 202
 Innerster Schrein 239
 Isis-Figur 295a

 Kampf-Stock 582c
 Kanopensarg
 Isis 266g
 Neith 266g
 Nephthys 266g
 Selket 266g
 Kanopenschrein 266a
 Kanopenschrein (Alabaster) 266b
 Kanopenschrein (Baldachin) 266
 Kanopenschrein (Isis-Figur) 266a
 Kappe 256, 4t
 Kette 108c
 Kindersarg 317a, 317a (1)
 Klapper 620 (13)
 Kleid 44w, 101p
 König auf Panther 289a, 289b
 Königs-Figur 275b, 275d, 296b
 Königs-Statue 22, 29
 Kopfstütze 101o, 403a, 403b, 403c, 403d
 Kuh-Bahre 73

 Löwenbahre 35
 Leinen 21ff, 21gg, 44b, 100f, 101r, 101s, 119, 261a, 291a

 Magische Figur (Djed) 260
 Magische Figur (Osiris) 257
 Magische Figur (Uschebti) 259
 Magischer Ziegel 263
 Mamu-Figur 281a
 Mandragora 585u
 Menkaret-Figur 74, 296a
 Miniatur einer aufgebahrten Mumie 331a
 Mittlerer Sarg 254
 Modell-Sarg 317b, 317b (1), 320, 320a, 320d
 Mumienstreifen 256b

 Nephthys-Figur 305a
 Nilpferd-Bahre 137

 Öl-Gefäß 60

 Palette 262, 271b, 271e (2), 620 (90)
 Panther-Kopf 21t, 44g
 Papyrusglätter 271g
 Parfüm-Gefäß 210
 Peitschenstock 333

- Pektoral 54*k*, 101*w*, 256*ooo*, 256*ppp*, 256*qqq*, 256*uuu*, 261*i*,
 261*j*, 261*m*, 261*n*, 261*o*, 261*p* (1), 261*p* (2), 261*p* (3), 267*k*,
 267*q*, 269*k*
 Podest für Goldstatue 108*a*
 Priesterthron 351
 Ptah-Figur 291*a*
 Ptah-Tatenen-Figur 292*a*
- Ringe 44*e*, 44*f*, 53*b*, 147*b*, 256*ccc*
- Sachmet-Figur 300*a*
 Salbgefäß 211, 240*bis*, 579
 Sarkophag 240
 Schild 350, 379*a*, 379*b*, 488*a*, 488*b*, 492, 545, 566
 Schilfkorb 271*a*
 Schlange 37*a*, 38*b*, 283*a*
 Schmuck-Kästchen 54*ddd*
 Schreibbinsen-Behälter 271*e* (1)
 Schreibbrett 387, 398
 Schreibpalette 367*l*, 367*m*, 620 (92)
 Schrein 209, 237, 238, 239, 487
 Schu-Figur 282*a*
 Sendet-Figur 294*a*
 Sichel 561
 sichelförmiger Stock 370*a*, 370*i*
 Siegel 3, 4, 5*c*, 10, 38*a*, 119, 179, 193, 195, 237*a*, 238*a*,
 266*b*, 271, 272, 283, 392, 413, 432, 434, 486, 489, 500,
 508, 536, 541, 560, 568, 571, o. Nr
 Skarabäus 1*a*, 44*l*, 44*o*, 44*gg*, 256*a*, 256*q*, 269*a* (4)
 Sopdu-Figur 283*b*
 Spiegelkasten 269*b*, 271*c*
 Stab 48*e*, 48*p*, 48*s*, 50*jj*, 50*xx*, 98, 100*a*, 135*h*, 135*s*, 204,
 213, 224, 227*a*, 227*b*, 227*c*, 227*d*, 227*e*, 229, 468*c*, 468*d*,
 468*e*, 468*f*, 468*g*, 468*j*, 468*k*, 468*l*, 468*m*, 468*n*, 582*b*, s. a.
 Stock
 Steinbock-Vase 584
 Stock 48*a*, 48*b*, 48*c*, 48*d*, 48*o*, 48*q*, 48*w*, 50*nn*, 50*pp*, 50*ss*,
 135*aa*, 135*q*, 370*a*, 370*i*, 582*c*
 Stoff 21*ff*, 21*gg*, 44*b*, 100*f*, 101*r*, 101*s*, 119, 261*a*, 291*a*
 Stola 269*o*
 Stuhl 87
 Szepter 577
- Tata-Figur 303*a*
 Thronsessel 91
 Ton-Gefäß 406, 614*a–k*
 Trompete 50*gg*, 175
 Truhe 21, 44, 101, 271, 551, 585
- Uschebti 110/60825, 318*a*/60830, 318*b*/60826,
 318*c*/60837, 319*a*/60944, 319*b*/60945, 319*c*/60895,
 319*d*/60929, 319*e*/60928, 319*f*/60854, 319*g*/60865,
 319*h*/60939, 319*i*/60940, 319*j*/60941, 319*k*/60942,
 319*l*/60943, 319*m*/60875, 319*n*/60896, 319*o*/60907,
 322*a*/61023, 322*b*/61007, 322*c*/61008, 322*d*/61009,
 322*e*/60990, 322*f*/60991, 322*g*/61041, 322*h*/61042,
 322*i*/61019, 322*j*/61039, 323*a*/60855, 323*b*/60856,
 323*c*/60863, 323*d*/60858, 323*e*/60862, 323*f*/60861,
 323*g*/60870, 323*h*?/60871, 323*i*/60872, 323*j*?/60864,
 323*k*?/60869, 323*l*/60852, 323*m*?/60853, 323*n*/60851,
 323*o*/60930, 323*p*/60897, 324*a*/60918, 324*b*/60919,
 324*c*?/60923, 324*d*/60924, 324*e*/60925, [A324*f*]/60926,
 324*g*/60898, 324*h*/60905, 324*i*/60906, 324*j*/60908,
 324*k*/60909, 324*l*/60910, 324*m*/60899, 324*n*/60911,
 324*o*/60912, 324*p*/60917, 324*q*?/60900, 324*r*?/60901,
 324*s*/60931, 324*t*/60932, 325*a*/60838, 325*b*/60839,
 325*c*/60764, 325*d*?/60765, 325*e*?/60779, 325*f*/61122,
 326*a*/60835, 326*b*/60808, 326*c*/61051, 326*d*/61052,
 326*e*/61053, 326*f*/61055, 326*g*?/61056, 326*h*/61057,
 326*i*/61058, 326*j*/61059, 326*k*/61060, 326*l*?/61061,
 326*m*/61062, 326*n*/61063, 326*o*/61064, 326*p*/61090,
 326*q*/61099, 326*r*?/61100, 326*s*/61101, 326*t*?/61102,
 326*u*/61103, 326*v*?/61123, 326*w*/61124, 326*x*/61144,
 326*y*/61125, 327*a*/61153, 327*b*/61154, 327*c*/61155,
 327*d*?/61156, 327*e*?/61157, 327*f*/61158, 327*g*/61159,
 327*h*/61105, 327*i*/61106, 327*j*/61107, 327*k*/61111,
 327*l*/61147, 327*m*/61148, 327*n*/61149, 327*o*/61126,
 327*p*/61127, 327*q*/61150, 327*r*/61151, 327*s*/61145,
 327*t*/61146, 327*u*/61128, 327*v*/61129, 327*w*/61130,
 327*x*/61131, 327*y*/61132, 327*z*/61133, 327*aa*/61134,
 327*bb*/61135, 327*cc*/61136, 327*dd*/61137, 327*ee*/61112,
 327*ff*/61113, 327*gg*/61114, 327*hh*?/61138, 327*ii*?/61115,
 327*jj*/61116, 327*kk*/61117, 327*ll*/61118, 327*mm*?/61120,
 327*nn*/61121, 328*a*/60985, 328*b*/60962, 328*c*/60956,
 328*d*/60955, 328*e*?/60965, 328*f*?/60949, 328*g*?/60954,
 328*h*/60979, 328*i*/60980, 328*j*/60981, 328*k*/60988,
 328*l*/60970, 328*m*/60982, 328*n*?/60968, 329*a*/60992,
 329*b*/60993, 329*c*/60994, 329*d*/60995, 329*e*/61010,
 329*f*/61011, 329*g*/61012, 329*h*/61024, 329*i*/61025,
 329*j*/61026, 329*k*?/61027, 329*l*/61045, 330*a*/60820,
 330*b*/60821, 330*c*/60823, 330*d*/60822, 330*e*/60824*a*,
 330*f*/60824*b*, 330*g*/60834, 330*h*/60833, 330*i*/60827,
 330*j*/60828, 330*k*/60836, 330*l*/61049, 330*m*/61050,
 330*n*/61046, 330*o*?/61048, 337*a*/61034, 337*a*/61035,
 337*a*/61036, 337*a*/61037, 337*a*/61038, 337*b*/61006,
 337*b*/61013, 337*c*/60999, 337*c*/61000, 337*c*/61001,
 380*a*/61047, 380*b*/60958, 380*c*/60957, 380*d*/60960,
 380*d*/60966, 380*e*/60987, 380*f*/60969, 380*g*/60989,
 380*g*/60974, 418*a*/60857, 418*a*/60859, 418*a*/60860,
 418*b*?/60873, 418*b*/60874, 418*c*/60902, 418*d*/60904,
 418*d*/60933, 418*d*/60935, 418*d*/60936, 418*e*?/60850,
 418*e*/60847, 418*e*/60848, 418*e*/60849, 418*f*?/60866,
 418*f*?/60867, 418*f*?/60868, 418*g*?/60891, 418*g*?/60903,
 418*g*?/60927, 458/60829, 459*a*?/60964, 459*a*/60963,
 459*a*/60967, 459*b*/60986, 459*c*/60953, 459*d*/60983,
 459*d*/60984, 459*e*?/60950, 459*e*?/60951, 459*e*/60952,
 459*e*/60959, 459*e*/60961, 459*f*?/60978, 459*f*/60971,
 459*f*/60972, 459*f*/60973, 459*f*/60975, 459*f*/60976,
 459*f*/60977, 459*g*/60948, 496*a*/60840, 496*b*/60758,
 496*b*/60759, 496*b*/60760, 496*c*?/60766, 496*c*/60767,
 496*d*/61108, 496*d*/61109, 496*d*/61110, 496*e*?/61119,
 496*e*?/61152, 496*e*/61139, 496*e*/61140, 496*e*/61141,
 496*e*/61142, 496*e*/61143, 512*a*?/60782, 512*a*?/60786,
 512*a*?/60787, 512*a*/60783, 512*a*/60784, 512*a*/60785,
 512*a*/60788, 512*b*?/60809, 512*b*/60793, 512*c*/60800,
 512*c*/60806, 512*c*/60807, 512*c*/60810, 512*d*/60768,
 512*d*/60769, 512*d*/60771, 512*e*?/60816, 512*e*/60811,
 512*e*/60812, 512*e*/60817, 514*a*?/61031, 514*a*?/61032,
 514*a*?/61033, 514*a*/61028, 514*b*/61016, 514*b*/61017,
 514*b*/61018, 514*c*/60997, 514*c*/60998, 514*d*/60996,
 517*a*/60774, 517*a*/60775, 517*b*/60778, 517*b*/60780,
 517*b*/60781, 517*c*/60799, 517*d*?/60777, 517*d*?/60814,
 517*e*?/60886, 517*e*/60934, 517*f*?/60879, 517*f*?/60893,
 517*g*/60938, 517*h*/60913, 517*h*/60920, 517*h*/60921,
 517*h*/60922, 519*a*/61054, 519*b*/61095, 519*c*/61096,
 519*c*/61097, 519*c*/61098, 519*c*/87852, 519*d*/61104,
 519*e*?/61162, 519*e*/61160, 519*e*/61163, 519*e*/61164,
 519*f*/61161, 519*f*/61165, 519*f*/61166, 519*f*/61167,
 519*f*/61168, 601/60831, 602*a*?/60762, 602*a*?/60763,
 602*a*/60761, 602*b*/60846, 602*c*/60842, 602*d*/60844,
 602*d*/60845, 602*e*/60841, 602*e*/60843, 602*f*?/61079,
 602*f*?/87854, 602*f*/61065, 602*f*/61066, 602*f*/61067,
 602*f*/61068, 602*f*/61069, 602*f*/61070, 602*f*/61071,
 602*f*/61072, 602*f*/61073, 602*f*/61074, 602*f*/61075,
 602*f*/61076, 602*f*/61077, 602*f*/61078, 602*f*/61080,
 602*f*/61081, 602*f*/61082, 602*f*/61083, 602*f*/61084,
 602*f*/61085, 602*f*/61086, 602*f*/61087, 602*f*/61088,
 602*f*/61089, 602*f*/61091, 602*f*/61092, 602*f*/61093,

- 602f/61094, 602ff/87853, 605a/61043, 605b/61044,
 605c/61020, 605c/61021, 605c/61022, 605d/61029,
 605d/61030, 605e/61014, 605e/61015, 605f/61040,
 605g?/61002, 605g?/61004, 605g/61003, 605g/61005,
 608a/60801, 608a/60802, 608a/60803, 608a/60804,
 608a/60805, 608b/60795, 608b/60796, 608c?/60791,
 608c/60789, 608c/60790, 608c/60792, 608c/60794,
 608c/60797, 608c/60798, 608c/60818, 608c/60819,
 608d/60776, 608d/60813, 608d/60815, 608e/60770,
 608e/60772, 608e/60773, 611a?/60882, 611a?/60914,
 611a?/60915, 611a?/60916, 611b?/60877, 611b?/60883,
 611b?/60890, 611b/60880, 611b/60885, 611b/60889,
 611b/60892, 611c?/60884, 611c?/60887, 611c?/60937,
 611c/60876, 611c/60878, 611c/60881, 611c/60888,
 611c/60894, 620 (113)/60832
- Wagen 46l, 120, 120a, 121, 122
 Weinkrug 11, 180, 195, 206, 362, 392, 411, 413, 432, 434,
 486, 489, 490, 500, 508, 509, 516, 523, 536, 539, 541,
 549, 560, 563, 568, 570, 571, o. Nr
 Werkzeug 620 (58)
 Wurfholz 54d, 54e, 367o

Teil II

Konkordanz der Nummernsysteme
des 'Journal d'Entrée' des Ägyptischen Museums Kairo,
der *Handlist to Howard Carter's Catalogue of
Objects in Tutankhamūn's Tomb*
und der Ausstellungs-Nummer
des Ägyptischen Museums Kairo

Die nachfolgende Konkordanz soll helfen, die unterschiedlichen Zitierweisen für Objekte aus dem Tutanchamun-Grab zu vereinheitlichen. Die Angaben stützen sich dabei im wesentlichen auf das 'Journal d'Entrée' (JE) des Ägyptischen Museums Kairo, beziehen aber auch die Angaben des 'Special Register' (S vor vierstelliger Zahl, z.B. S-4455) und die Nummer des 'Temporary Register' (= Temporary Number) (z.B. 27/3/34/01) mit ein. Die JE-Nummern reichen von 60664 bis 62762b. Die Nummern 87847–57 sind erst lange nach den übrigen Objekten in das Museum gekommen und dort registriert worden. Das Journal d'Entrée ordnet die Stücke prinzipiell nach Objektgattungen, d.h. wenn man ein bestimmtes Stück—evtl. über die Konkordanz—mit einer JE-Nummer verbinden kann, ist es wahrscheinlich, daß sich ähnliche Stücke im Umkreis dieser Zahl finden lassen.

Im Gegensatz zu dem System des JE sind die Nummern, die Howard Carter den Objekten bei ihrer Bergung gegeben hat (**Carter**-Nummer), nach den Fundumständen geordnet. Eng benachbarte Zahlen besagen, daß die Objekte auch im Tutanchamun-Grab relativ eng benachbart gefunden wurden. Die Kombination von Carter-Nummer und JE-Nummer erlaubt es also, sowohl den relativen Fundzusammenhang als auch den relativen Objektgruppen-Zusammenhang schnell festzustellen. Nicht zu jeder JE-Nummer findet sich in der Konkordanz eine Carter-Entsprechung, ebenso haben auch manche Carter-Nummern keine JE-Entsprechung. Das liegt z.T. daran, daß nicht alle Tutanchamun-Stücke Fundnummern bekommen haben, und auch nicht alle in das Museum von Kairo gelangt sind. Einiges ist noch in Theben magaziniert bzw. noch im Tutanchamun-Grab. Des Weiteren sind beim Inventarisieren nicht alle Carter-Nummern in das Journal d'Entrée eingetragen worden. Manche Zahlen wurden auch verwechselt. Bei der Erstellung der Konkordanz konnten in einigen besonders deutlichen Fällen die Angaben ergänzt oder berichtigt werden. In anderen Fällen mußten unsichere Identifizierungen durch '?' in Frage gestellt werden. Stücke, die vermutlich aus dem Tutanchamun-Fund stammen, aber in andere Museen als die in Kairo und—von hier dann—nach Luxor gelangten, sind weder in der Konkordanz, noch im Corpus der hieroglyphischen Inschriften berücksichtigt.

Die dritte Kolumne der Konkordanz gibt die **Ausstellungs**nummer (Exhibition Number) an, wie sie z.B. in der *Description Sommaire des Monuments* des Ägyptischen Museums Kairo Verwendung findet. Die Konkordanz ist in drei Teile gegliedert. Der erste Teil ist nach den JE-Nummern geordnet, der zweite Teil nach den Carter-Nummern und der dritte Teil nach den Ausstellungs-Nummern. Eine Leerstelle in einer Kolumne bedeutet daß es keine Angabe zu diesem Objekt im Journal d'Entrée gibt. '—' ist so als Strich im Journal angegeben.

Am Schluß der Konkordanz befinden sich zwei Indices (jeweils deutsch und englisch), die—alphabetisch nach Objektgruppen bzw. nach fortlaufenden JE-Zahlen geordnet—helfen sollen, das Tutanchamun-Material inhaltlich zu erschließen.

The concordances which follow are intended to bring together the various numbering systems that are used for objects from the tomb of Tutankhamun. They are based principally on the Journal d'Entrée (**JE**) of the Egyptian Museum on Cairo, but also include numbers in the 'Special Register' (**S** followed by hyphen and four-digit number) and in the 'Temporary Register' (Temporary Numbers, for example 27/3/24/01). The JE numbers run from 60664 to 62762*b*. The objects numbered 87847–57 came into the Museum and were registered at a much later date. In principle, the Journal d'Entrée orders pieces according to categories of objects, so that if a JE number can be found for a piece—perhaps through the concordance—adjacent numbers will probably belong to similar pieces.

In contrast with the JE system, the numbers Howard Carter assigned to the objects as they were recovered (**Carter** numbers) are ordered according to findspots. Thus, a combination of Carter numbers and JE numbers makes it possible to establish quickly both the find context and the object category of a piece. Not every JE number in the concordance has a corresponding Carter number, while some Carter numbers have no JE number. Reasons for this are that not all objects from the tomb of Tutankhamun received excavator's numbers, while some objects did not reach the Cairo Museum. Some are in magazines in Thebes or still in the tomb itself. Further, when the objects were registered in the Cairo Museum, the Carter numbers of some were not recorded. Some objects were given the numbers of others. In establishing the concordance, we were able to supplement or correct some of the information in the Journal d'Entrée. In other cases, uncertain identifications are indicated with a question mark '?'. Pieces that may come from the Tutankhamun find but are now in museums other than the Cairo Museum or the Luxor Museum (which received some objects from the Cairo Museum) are not included in the concordance or in the Corpus of hieroglyphic inscriptions.

The third column in the concordance gives the Exhibition Numbers (**Ausstellungsnummer**) of objects, which are used, for example, in the Cairo Museum's *Description Sommaire des Monuments*.

The concordance is in three sections. The first section is ordered by JE Numbers, the second by Carter Numbers, and the third by Exhibition Numbers. Blanks in columns correspond to gaps in the Journal d'Entrée. '—' corresponds to a dash in the Journal d'Entrée.

At the end of the concordance are two indexes, which are given in both German and English. These are organized according to object categories thematically and are arranged alphabetically by category and by JE number respectively.

KONKORDANZ NACH JE-NUMMERN

JE	Carter	Ausstellung	JE	Carter	Ausstellung	JE	Carter	Ausstellung
S-4455	?	?	60679	256lll**	327	60731	289c	996
S-4456	von 21j?	?	60680	256ll**	328	60732	275a	423
S-4457-63	?	?	60681	256ll***	329	60733	282a	417
S-4464	von 54r?	950	60682	256ll****	330	60734	290a	422
S-4465	von 46c?	946	60683	256ll*****	331	60735	299a	420
S-4466	von 21s?	—	60684	256 4o	317	60736	264	395
S-4467	von 53?	947	60684	256r	317	60737	297a	426
S-4468	von 53?	947	60684	256s	317	60738	281a	424
S-4469	von 46qq?	949	60685	256j	270	60739	291a	432
S-4470	von 32?	—	60686	266	985	60740	294a	430
S-4471	von 193?	—	60686	266	455	60741	303a	431
S-4472	von 46b?	945	60686	266	456	60742	292a	433
S-4473	von 46rr?	957	60686	266	457	60743	261g	388
S-4474	?	—	60686	266	458	60744	261f	387
S-4476	von 46n?	944	60686	266a	985	60745	298a	429
S-4477	von 46kk?	—	60686	266a	455	60746	293a	434
S-4478	von 266g	—	60686	266a	456	60747	283b	418
S-4479	von 266g	—	60686	266a	457	60748	283c	419
S-4480	von 266g	—	60686	266a	458	60749	300a	428
S-4481	von 266g	—	60687	266b	984	60750	37a	19
S-4482	von 266g	—	60687	266c-f	437-40	60751	37	18
S-4483	von 35	—	60687	266c-f	1251	60752	38a	332
S-4486	von den Schreinen	—	60688	266g	452	60753	38	333
S-4487	von 207?	—	60689	266g	1184	60754	283a	427
S-4488	?	—	60690	266g	1185	60755	176	194
S-4490	von Wagen 'C'?	—	60691	266g	1186	60756	261g	391
S-4491	von 401	—	60692	317a	956-7	60757	267f	392
S-4491	von 355	—	60693	317a1	958-9	60758	496b	1538
S-4492	von 158o (10)	—	60694	317a2	960	60759	496b	1384
S-4493	von 158o (9)	—	60695	317b	961-2	60760	496b	1383
S-4494	—	—	60696	317b1	963-4	60761	602a	1382
S-4495	von 158o (12)	—	60697	320	470	60762	602a?	1541
S-4496	von 158o (6)	—	60698	320a	470	60763	602a	1539
S-4497	von 158o (15)	—	60699	320b	442	60764	325c	476
S-4498	von 158o (11)	—	60700	320d	443	60765	325d?	477
S-4499	?	—	60701	320e	444	60766	496c?	1540
S-4500	von 158o (19)	—	60702	320c	445	60767	496c	1542
60664	207	1322	60703	288	1064	60768	512d	1391
60665	208	1323	60704	438-65	1581	60769	512d	1450
60666	237	1321	60705	438-65	1581	60770	608e	1377
60666	237a	1249	60706	438-65	1581	60771	512d	1448
60667	238	1320	60707	22	96	60772	608e	1444
60667	238a	1250	60708	29	181	60773	608e	1442
60668	239	1319	60709	275c	407	60774	517a	1483
60669	235a	1188	60710	275e	994	60775	517a	1512
60670	254	222	60711	296	409	60776	608d	1537
60670	254	936	60712	275b	411	60777	517d?	1475
60671	255	219	60713	275d	995	60778	517b	1515
60671	255	935	60714	289b	410	60779	325e?	478
60672	256a	220	60715	289a	993	60780	517b	1394
60673	256b	336	60716	296a	408	60781	517b	1380
60674	256 4s	258	60717	54vv	80	60782	512a?	1543
60675	256 4p	259	60718	54ff	74	60783	512a	1379
60676	256ee	335	60719	54ee	64	60784	512a	1480
60677	256l	334	60720	331a	449	60785	512a	1513
60678	256lll*	327	60721	331	454	60786	512a?	1509
60678	256lll**	327	60722	116	16	60787	512a?	1508
60679	256lll*	327	60723	8	755	60788	512a	1507
			60724	295a	425	60789	608c	1511
			60725	305a	421	60790	608c	1474
			60726	301a	416	60791	608c?	1481
			60727	280a	415	60792	608c	1446
			60728	304b	414	60793	512b	1393
			60729	302a	413	60794	608c	1386
			60730	304a	412	60795	608b	1478

JE	Carter	Ausstellung	JE	Carter	Ausstellung	JE	Carter	Ausstellung
60796	608b	1477	60868	418f?	1417	60941	319j	1183
60797	608c	1388	60869	323k?	788	60942	319k	1103
60798	608c	1479	60870	323g	1099	60943	319l	795
60799	517c	1387	60871	323h?	1100	60944	319a	801
60800	512c	1510	60872	323i	1096	60945	319b	800
60801	608a	1392	60873	418b?	1405	60946	261f	386
60802	608a	1482	60874	418b	1404	60947	—	1216
60803	608a	1389	60875	319m	1113	60948	459g	1557
60804	608a	1340	60876	611c	1428	60949	328f?	1121
60805	608a	1514	60877	611b?	1352	60950	459e?	1558
60806	512c	1376	60878	611c	1353	60951	459e?	1546
60807	512c	1378	60879	517f	1354	60952	459e	1559
60808	326b	479	60880	611b	1355	60953	459c	1578
60809	512b?	1506	60881	611c	1356	60954	328g?	778
60810	512c	1473	60882	611a?	1357	60955	328d	775
60811	512e	1441	60883	611b?	1359	60956	328c	1114
60812	512e	1451	60884	611c?	1364	60957	380c	1562
60813	608d	1447	60885	611b	1365	60958	380b	1563
60814	517d?	1381	60886	517e?	1368	60959	459e	1577
60815	608d	1445	60887	611c?	1370	60960	380d	1561
60816	512e?	1385	60888	611c	1371	60961	459e	1560
60817	512e	1449	60889	611b	1374	60962	328b	776
60818	608c	1443	60890	611b?	1425	60963	459a	1555
60819	608c	1476	60891	418g?	1426	60964	459a?	1556
60820	330a	1086	60892	611b	1427	60965	328e?	1119
60821	330b	475	60893	517f?	1363	60966	380d	1559
60822	330d	1087	60894	611c	1372	60967	459a	1576
60823	330c	906	60895	319c	1102	60968	328n?	777
60824a	330e	473	60896	319n	804	60969	380f	1552
60824b	330f	474	60897	323p	1109	60970	328l	1120
60825	110	17	60898	324g	806	60971	459f	1570
60826	318b	463	60899	324m	807	60972	459f	1574
60827	330i	467	60900	324q?	1112	60973	459f	1534
60828	330j	468	60901	324r?	1110	60974	380g	1569
60829	458	1089	60902	418c	1399	60975	459f	1571
60830	318a	462	60903	418g?	1395	60976	459f	1573
60831	601	908	60904	418d	1422	60977	459f	1528
60832	620(113)	1090	60905	324h	794	60978	459f?	1463
60833	330h	466	60906	324i	799	60979	328h	1117
60834	330g	472	60907	319o	1111	60980	328i	1116
60835	326a	465	60908	324j	1108	60981	328j	1122
60836	330k	469	60909	324k	802	60982	328m	1115
60837	318c	907	60910	324l	789	60983	459d	1575
60838	325a	464	60911	324n	790	60984	459d	1553
60839	325b	1088	60912	324o	808	60985	328a	1123
60840	496a	1347	60913	517h	1373	60986	459b	1429
60841	602e	1526	60914	611a?	1360	60987	380e	1572
60842	602c	1525	60915	611a?	1361	60988	328k	1118
60843	602e	1495	60916	611a?	1362	60989	380f	1568
60844	602d	1494	60917	324p	809	60990	322e	1134
60845	602d	1493	60918	324a	1105	60991	322f	1133
60846	602b	1527	60919	324b	798	60992	329a	769
60847	418e	1403	60920	517h	1351	60993	329b	1125
60848	418e	1402	60921	517h	1358	60994	329c	771
60849	418e	1401	60922	517h	1424	60995	329d	1124
60850	418e?	1400	60923	324c?	1092	60996	514d	1471
60851	323n	787	60924	324d	1095	60997	514c	1529
60852	323l	797	60925	324e	1094	60998	514c	1530
60853	323m?	1091	60926	324f	1093	60999	337c	1464
60854	319f	1106	60927	418g?	1369	61000	337c	1465
60855	323a	784	60928	319e	1101	61001	337c	1468
60856	323b	1107	60929	319d	793	61002	605g?	1485
60857	418a	1397	60930	323o	803	61003	605g	1486
60858	323d	805	60931	324s	792	61004	605g?	1487
60859	418a	1398	60932	324r	791	61005	605g	1466
60860	418a	1396	60933	418d	1420	61006	337b	1532
60861	323f	786	60934	517e	1423	61007	322b	1126
60862	323e	785	60935	418d	1419	61008	322c	1127
60863	323c	783	60936	418d	1421	61009	322d	1131
60864	323j?	1097	60937	611c?	1366	61010	329e	1128
60865	319g	1098	60938	517g	1367	61011	329f	770
60866	418f?	1406	60939	319h	796	61012	329g	766
60867	418f?	1418	60940	319i	1104	61013	337b	1488

JE	Carter	Ausstellung	JE	Carter	Ausstellung	JE	Carter	Ausstellung
61014	605e	1492	61087	602f	1416	61160	519e	1462
61015	605e	1535	61088	602f	1409	61161	519f	1439
61016	514b	1489	61089	602f	1412	61162	519e?	1430
61017	514b	1490	61090	326p	1155	61163	519e	1431
61018	514b	1491	61091	602f	1496	61164	519e	1432
61019	322i	768	61092	602f	1497	61165	519f	1453
61020	605c	1452	61093	602f	1498	61166	519f	1454
61021	605c	1472	61094	602f	1516	61167	519f	1460
61022	605c	1440	61095	519b	1564	61168	519f	1461
61023	322a	767	61096	519c	1567	61169	94b	149
61024	329h	1132	61097	519c	1260	61170	106a	145
61025	329i	772	61098	519c	1565	61171	602g (?)	1247 (1)
61026	329j	1129	61099	326q	1182	61172	602g (?)	1247 (2)
61027	329k?	1130	61100	326r?	1176	61173	602g (?)	1247 (3)
61028	514a	1533	61101	326s	816	61174	602g (?)	1247 (4)
61029	605d	1545	61102	326t?	1175	61175	602g (?)	1247 (5)
61030	605d	1544	61103	326u	817	61176	602g (?)	1247 (6)
61031	514a?	1547	61104	519d	1375	61177	602g (?)	1247 (7)
61032	514a?	1550	61105	327h	1167	61178	602g (?)	1247 (8)
61033	514a?	1467	61106	327i	812	61179	602g (?)	1247 (9)
61034	337a	1469	61107	327j	1169	61180	602g (?)	1247 (10)
61035	337a	1470	61108	496d	1549	61181	602g (?)	1247 (11)
61036	337a	1548	61109	496d	1531	61182	602g (?)	1247 (12)
61037	337a	1536	61110	496d	1459	61183	602g (?)	1247 (21)
61038	337a	1551	61111	327k	1168	61184	602g (?)	1247 (22)
61039	322j	774	61112	327ee	1153	61185	602g (?)	1247 (23)
61040	605f	1484	61113	327ff	823	61186	602g (?)	1247 (24)
61041	322g	1136	61114	327gg	1170	61187	602g (?)	1247 (25)
61042	322h	773	61115	327ii?	1149	61188	602g (?)	1247 (38)
61043	605a	1436	61116	327jj	1173	61189	602g (?)	1247 (39)
61044	605b	1435	61117	327kk	1152	61190	602g (?)	1247 (40)
61045	329l	781	61118	327ll	1162	61191	602g (?)	1246 (41)
61046	330n	1135	61119	496e?	1455	61192	602g (?)	1246 (42)
61047	380a	1457	61120	327mm?	825	61193	602g (?)	1246 (43)
61048	330o?	782	61121	327nn	1172	61194	602g (?)	1246 (44)
61049	330l	780	61122	325f	1154	61195	602g (?)	1246 (45)
61050	330m	779	61123	326v?	1148	61196	602g (?)	1246 (46)
61051	326c	810	61124	326w	1147	61197	602g (?)	1246 (47)
61052	326d	1171	61125	326y	1138	61198	602g (?)	1246 (48)
61053	326e	811	61126	327o	827	61199	602g (?)	1246 (49)
61054	519a	1566	61127	327p	1140	61200	602g (?)	1246 (30)
61055	326f	1160	61128	327u	1145	61201	602g (?)	1246 (29)
61056	326g?	1159	61129	327v	1137	61202	602g (?)	1246 (28)
61057	326h	1150	61130	327w	820	61203	602g (?)	1246 (50)
61058	326i	1161	61131	327x	1144	61204	602g (?)	1246 (51)
61059	326j	813	61132	327y	1141	61205	602g (?)	1246 (52)
61060	326k	1156	61133	327z	1143	61206	602g (?)	1246 (53)
61061	326l?	1157	61134	327aa	826	61207	602g (?)	1246 (54)
61062	326m	1158	61135	327bb	1151	61208	602g (?)	1246 (55)
61063	326n	814	61136	327cc	1139	61209	602g (?)	1246 (27)
61064	326o	1146	61137	327dd	815	61210	602g (?)	1246 (56)
61065	602f	1518	61138	327hh?	1163	61211	602g (?)	1246 (57)
61066	602f	1499	61139	496e	1438	61212	602g (?)	1246 (58)
61067	602f	1500	61140	496e	1433	61213	602g (?)	1246 (59)
61068	602f	1501	61141	496e	1437	61214	602g (?)	1246 (60)
61069	602f	1502	61142	496e	1456	61215	602g (?)	1246 (61)
61070	602f	1503	61143	496e	1458	61216	602g (?)	1246 (62)
61071	602f	1504	61144	326x	1174	61217	602g (?)	1246 (63)
61072	602f	1505	61145	327s	818	61218	602g (?)	1246 (64)
61073	602f	1517	61146	327t	1166	61219	602g (?)	1246 (65)
61074	602f	1519	61147	327l	824	61220	602g (?)	1246 (66)
61075	602f	1520	61148	327m	819	61221	602g (?)	1246 (67)
61076	602f	1521	61149	327n	1142	61222	602g (?)	1246 (26)
61077	602f	1522	61150	327q	1164	61223	602g (?)	1246 (31)
61078	602f	1523	61151	327r	1165	61224	602g (?)	1246 (37)
61079	602f?	1524	61152	496e?	1434	61225	602g (?)	1246 (36)
61080	602f	1407	61153	327a	1178	61226	602g (?)	1246 (35)
61081	602f	1408	61154	327b	822	61227	602g (?)	1246 (34)
61082	602f	1410	61155	327c	1180	61228	602g (?)	1246 (33)
61083	602f	1411	61156	327d?	1181	61229	602g (?)	1246 (32)
61084	602f	1413	61157	327e?	1177	61230	602g (?)	1246 (30)
61085	602f	1414	61158	327f	1179	61230	602g (?)	3020
61086	602f	1415	61159	327g	821	61231	602g (?)	1246 (36)

JE	Carter	Ausstellung	JE	Carter	Ausstellung	JE	Carter	Ausstellung
61231	602g (?)	3025	61288	620 (68)	711	61358	610	3091
61232	602g (?)	1246 (9–11)	61289	147d	148	61359	556	3090
61233	602g (?)	1246 (12–21)	61290	620 (57)	677	61360	375	3086
61234	602g (?)	1246 (22–25)	61291	620 (54)	678	61361	463	3087
61234	602g (?)	3024	61292	402	568	61362	481	3088
61235	602g (?)	1246 (27)	61293	44v	150	61363	192	497
61236	602g (?)	1246 (28)	61294	44p	151	61364	191	496
61237	602g (?)	1246 (29)	61295	316a	1195	61365	190	495
61237	602g (?)	3027	61296	316b	1196	61366	189	494
61238	602g (?)	1246 (30)	61297	316c	1197	61367	188	493
61239	602g (?)	1246 (31)	61298	316d	1198	61368	187	492
61240	602g (?)	1246 (32)	61299	316e	1199	61369	186	491
61241	602g (?)	1246 (1–2)	61300	316f	1200	61370	185	490
61241	602g (?)	3001	61301	316g	1201	61371	184	489
61242	602g (?)	1246 (3–4)	61302	316h	1202	61372	183	488
61242	602g (?)	3002	61303	316i	1203	61373	182	487
61243	602g (?)	1246 (5–6)	61304	316j	1204	61374	194	435
61243	602g (?)	3000	61305	316k	1205	61375	202	436
61244	602g (?)	1246 (7–9)	61306	316l	1206	61376	258	1233
61244	602g (?)	3004	61307	316m	1207	61377	259	1234
61245	602g (?)	1246 (10–11)	61308	316n	1208	61378	257	1232
61245	602g (?)	3003	61309	316o	1209	61379	260	1235
61246	602g (?)	1246 (12–13)	61310	316p	1210	61380	271a	401
61246	602g (?)	3005	61311	620 (55)	682a	61381	42	173
61247	602g (?)	1246 (14–15)	61312	620 (55)	682b	61382	26	513
61247	602g (?)	3006	61313	620 (55)	682c	61382	119	512
61248	602g (?)	1246 (19–20)	61314	620 (55)	682d	61383	589	703
61249	602g (?)	1246 (18)	61315	50dd**	55	61384	422	729
61250	602g (?)	1246 (1–15)	61316	50ee*	56	61385	367c	731
61250	602g (?)	1246 (19–32)	61317	50ee**	57	61386	93	1635
61250	602g (?)	3008	61318	50ff**	58	61387	117	1636
61251	602g (?)	1246 (16–17)	61319	50ff**	59	61388	129	1637
61252	602g (?)	1246 (33–34)	61320	50dd	54	61389	357	728
61252	602g (?)	3029	61321	46aa	146	61390	32r	511
61253	602g (?)	1246 (35–36)	61322	585aa	560	61390	146	510
61254	602g (?)	1246 (37)	61323	274	1037	61391	97	174
61254	602g (?)	3032	61324	274	919	61392	338	704
61255	602g (?)	1246 (38–39)	61325	54i	143	61393	440a	705
61255	602g (?)	3033	61326	279a	446	61394	616	706
61256	602g (?)	1246 (40)	61327	277	922	61395	589a	730
61256	602g (?)	3035	61328	336	459	61396	62j	3050
61257	602g (?)	1246 (41–44)	61329	276	3103	61397	?	3049
61257	602g (?)	3036	61330	321	450	61398	62? w	3048
61258	602g (?)	3038	61331	334	1326	61399	62? ww	3051
61259	602g (?)	3039	61332	598	3100	61400	—	1314
61260	602g (?)	3040	61332	332	3100	61401	62ss	1315
61261	602g (?)	3041	61333	572	3097	61402	62a	3080
61262	602g (?)	3042	61333	513	3097	61403	62dd	1318
61263a–e	331	454	61334	284	480	61404	—	1313
61264	561	573	61335	309	483	61405	62ff	3078
61265	620 (94)	978	61336	314	486	61406	62q	3065
61266	32o	152a	61337	491	3099	61407	62d	3062
61267	32o	152b	61337	437	3099	61408	62s	3052
61268	32o	152c	61338	306	485	61409	62b	1316
61269	32o	152d	61339	310	484	61410	62e	3073
61270	620 (62)	674	61340	287	3102	61411	62l	3071
61271	620 (63)	675	61341	273	3098	61412	62n	3077
61272	32p	153a	61342	597	3101	61413	62t	3058
61273	32p	153b	61343	285	460	61414	62rr	3076
61274	39q	154a	61344	311	481	61415	62oo	3070
61275	39q	154b	61345	286	461	61416	62f	3053
61276	39q	154c	61346	307	3106	61417	62m	3045
61277	39q	154d	61347	308	482	61418	—	1317
61278	39q	154e	61348	312	1035	61419	62ff	3059
61279	620 (58)	680	61349	464	3104	61420	62u	3067
61280	620 (59)	679	61350	313	471	61421	62ee	3072
61281	54c	147	61351	581	3089	61422	62aa	3075
61282	620 (53)	676	61352	462	3095	61423	62o	3057
61283	—	1265a	61353	612	3093	61424	—	3055
61284	—	1265b	61354	491	3096	61425	62qq	3079
61285	—	1265c	61355	460	3085	61426	62v	3074
61286	—	1265d	61356	609	3094	61427	—	3043
61287	620 (56)	681	61357	617	3092	61428	—	3056

JE	Carter	Ausstellung	JE	Carter	Ausstellung	JE	Carter	Ausstellung
61429	62r	3069	61494	115	918	61563	46a (2)	—
61430	—	3084	61495	79	750	61564	370qq	—
61431	62b ?	3083	61495	574	750	61565	370oo	—
61432	62g	3082	61496	240 bis	223	61566	370pp	—
61433	62y	3081	61497	267c	355	61567	370vv	868–71
61434	62tt	3068	61498	54hh	92	61568	370ww	861–3
61435	62vv	3066	61499	620 (121)	1242	61569	596v	854
61436	62gg	3064	61500a–b	1k	1243	61570	48x	926
61437	62cc	3063	61501	270	902	61571	585cc	942
61438	62ii	3060	61502	335	441	61572	585y	1084
61439	62ll	3061	61503	77a	1590	61573	585y	1084
61440	—	3054	61504	48e (1?)	1589	61574	—	927b
61441	62u	3047	61505	228	830	61575	—	927a
61442	62w	3046	61506	247	1587	61576	379b	754
61443	—	3044	61507	244	1588	61577	379a	753
61444	261	447	61508	226	833	61578	488b	1070
61445	32	5	61509	234	1595	61579	350	1066
61446	403	738	61510	222	832	61580	492	1069
61447	386	739	61511	246	1591	61581	488a	1068
61448	56	1341	61512	70	1594	61582	545	733
61449	54ddd	89	61513	225b	1592	61583	566	1067
61450	550	1641	61514	225a	1593	61584	256dd	225
61450	546	1641	61515	241	831	61585	256k	226
61451	587	1639	61516	596t	928	61586	—	117
61451	367	1639	61517	48h	120	61587	—	118
61452	54	917	61518	596q	1599	61588	582a	537
61453	330	1640	61519	77b	3141	61589	620 (52)	538
61454	50	94	61520	48g	3113	61590	620 (60?)	551
61455	68	921	61521	370gg	3140	61591	620 (61)	555
61456	585	752	61522	153	3117	61592	370w	624
61457	547	751	61523	48l	522	61593	370x	625
61457	615	751	61524	48g	523	61594	370z	1583
61458	271	451	61525	48j (1)	128	61595	370bb	628
61459	—	1337	61526	48k (1)	121	61596	370m	614
61460	—	1339	61527	135z	3110	61597	370o	1062
61461	268	453	61528	370ff	3114	61598	370p	1063
61462	267	397	61529	370jj	3111	61599	370q	1060
61463	269a	1340	61530	370ii	1600	61600	370s	1059
61463	270b	1340	61531	596m	1597	61601	370r	1061
61464	453	1338	61532	596k	1596	61602	370n	1058
61465	14a	91	61533	48j (2)	524	61603	370t	619
61466	40	12	61534	370hh	3116	61604	370u	622
61467	21	324	61535	596s	3115	61605	370k	612
61468	101	21	61536	596l	1601	61606	370l	613
61469	entfällt	entfällt	61537	48i (2)	119	61607	370cc	629
61470	272	920	61538	370kk	1598	61608	370aa	623
61471	270	903	61539	596r	3112	61609a	370dd	630
61472	279	1047	61540	596n	3109	61609b	367o	632
61473	315	1048	61541	596o	3108	61610	370v	633
61474	316	916	61542	596p	929	61611	307f	634
61475	317	1049	61543	370ll	930	61612	620 (5)	636
61476	44	13	61544	48i (1)	127	61613	620 (4)	635
61477	551	1189	61545	48f	520	61614	620 (6)	637
61477	540	1189	61546	370mm	940	61615a	54d	141
61478	575	899	61547	247	1212	61615b	620 (7)	1057
61479	493	1036	61548	390	840–843	61616	620 (8)	639
61479	494	1036	61548	430	840–843	61617	54e	140
61480	43	1342	61549	370ss	844–847	61618	620 (11)	641
61480	522	1342	61550	370nn	848–850	61619	620 (12)	1584
61481	108	14	61551	370mn	851	61620	370ee	631
61481	108a	506	61552	596v	859–860	61621	620 (10)	1038
61482	487	744	61553	370ww	3171 (8)	61622	620 (9)	640
61483	318	1632	61553	370xx	3172 (1,2)	61623	233	217
61484	322	1631	61554	370tt	864–867	61624	218	218
61485	325	1311	61555	370rr	855–858	61625	—	981
61486	326	1312	61556	370uu	872–876	61626	—	526
61487	328	1633	61557	370vv	877–884	61627	50ll	—
61488	329	1634	61558	370zz	1638	61628	50v	—
61489	193	193	61559	370oo	852–853	61629	50mm	—
61490	269	396	61560	243	834–9	61630	50aa	—
61491	367k	977	61560	248	834–9	61631	50zz ?	1644
61492	620 (95)	643	61561	48y	—	61632	—	527
61493	14b	93	61562	46a (3)	—	61633	50—?	1645

JE	Carter	Ausstellung	JE	Carter	Ausstellung	JE	Carter	Ausstellung
61634	—	528	61707	135l	—	61780	620 (21)	689
61635	50y	1643	61708	135n	—	61781	620 (22)	690
61636	50cc	1642	61709	468k	1610	61782	620 (23)	691
61637	48m	—	61710	468l	1609	61783	261k	384
61638	50pp	126	61711	468n	1056	61784	620 (26)	702
61639	370a	741	61712	468m	1608	61785	25o	192
61640	370b	1030	61713	48e	130	61786	620 (14)	685
61641	370c	1027	61714	468o	1051	61787	620 (15)	686
61642	370e	1031	61715	95	131	61788	620 (16)	687
61643	370f	1029	61716	231b	1614	61789	620 (17)	688
61644	370g	1032	61717	216b	1613	61790	99a	160
61645	607b	1033	61718	231a	1611	61791	620 (24)	696
61646	—	1630	61719	216a	1612	61792	587d	700
61647	607d	740	61720	135r	—	61793	—	—
61648	607e	1028	61721	135i	—	806	367r	658–61
61649	607c	742	61722	135w	—	61793	—	—
61650	607h	743	61723	50qq	—	806	367r	1007 (5–14)
61651	607i	1034	61724	230	1620	61807	261e	389a
61652	582b	737	61725	135v	—	61808	261e	389b
61653	50xx	134	61726	227e	215	61809–23	367q	1006 (1–15)
61654	582c	662	61727	50oo	122	61824–7	367r	1007 (1–4)
61655	582d	663	61728	229	514	61828	620 (18)	692
61656	582e	664	61729	—	529	61829	620 (19)	693
61657	582f	665	61730	98	123	61830	620 (20)	694
61658	619b	666	61731	—	525	61831	587b	695
61659	619c	667	61732	50uu	175	61832	620 (25)	701
61660	619d	668	61733	48d	176	61833	46y	159
61661	582i	652	61734	100a	177	61834	256fff	276
61662	582g	1653	61735	48b	178	61835	256d	311
61663	582h	1654	61736	48c	179	61836	256jii	300
61664	619a	1655	61737	48a	180	61837	256iii	299
61665	235a	195	61738	100l?	519	61838	256m	298
61666	235b	196	61739	596i	980	61839	256c	297
61667	204	216	61740	596s?	736	61840	256ttt	310
61668	221	1618	61741	135aa	135	61841	256kkk	309
61669	217b	955	61742	213	213	61842	256 4r	292
61670	468a	—	61743	227d	214	61843	256 4i	305
61671	468b	—	61744	468h	1052	61844	256 4i bis	302
61672	48p	1628	61745	468j	1053	61845	256 4l	304
61673	50jj	133	61746	468g	1054	61846	256 4j	306
61674	224	197	61747	468e	1055	61847	256 4h	303
61675	(13 ?)5vv	—	61748	468i	1603	61848	256zzz	269
61676	48n	—	61749	—	1604	61849	138	158c
61677	135y	—	61750	468c	1605	61850	138	158a
61678	48o	—	61751	468e	1606	61851	138	158b
61679	596d	1622	61752	468d	1607	61852	256iii 3	291
61680	214b	—	61753	227c	189	61853	256 4q	233
61681	596g	1050	61754	50nn	129	61854	256 4k	307
61682	135q	979	61755	227b	190	61855	256 4f	308
61683	48r (?)	—	61756	227a	191	61856	256 4g	301
61684	48t	—	61757	212	—	61857	620 (72)	715
61685	48u	—	61758	215	—	61858	620 (73)	716
61686	135u	—	61759	577	536	61859	261f	385
61687	135r	—	61760	269e	404	61860	256ggg	271
61688	135b	—	61761	269f	405	61861	256 4b	272
61689	135j	—	61762	44u	86	61862	620 (71)	714
61690	135m	—	61763	269d	403	61863	256 4a	274
61691	135f	—	61764	269h	406	61864	256yyy	275
61692	135c	—	61765	236	1619	61865	256xxx	273
61693	135a	—	61766	232	953	61866	620 (67)	710
61694	135k	—	61767	219	1617	61867	399b	697
61695	135g	—	61768	217a	1616	61868a	620 (28)	698
61696	135e	—	61769	135x	1621	61868b	620 (27)	699
61697	135p	—	61770	135s	—	61869	256 4v	296
61698	596f	1623	61771	370j	952	61870	585u	708a
61699	48q	1625	61772	223a	1615	61871	585u	708b
61700	50ww	1624	61773	223b	954	61872	44l	79
61701	48w	1629	61774	201	171	61873	44k	82
61702	48s	1627	61775	200	170	61874	44gg	81
61703	48v	1626	61776	199	169	61875	256nnn	316
61704	214a	—	61777	196	168	61876	256mmm	315
61705	135o	—	61778	256kk	294	61877	256z	314
61706	135—?	—	61779	256hhh	293	61878	256i	517

JE	Carter	Ausstellung	JE	Carter	Ausstellung	JE	Carter	Ausstellung
61879	256i2	976	61949	261j	373	61992a	333	1701
61880	256aa*	518	61950	101w	943	61992b-c	333	1701
61881	256aa**	516	61951	256rrr	232	61992f	333	1701
61882	—	1264b	61952	108c	85	61992d	—	1334
61883	—	1264a	61953	620 (77)	718	61992e	333	—
61884	267d	343	61954	620 (76)	717	61993a	161	1324
61885	267i u. l	344	61955	620 (78)	719	61993a	163	1324
61886	267a	348	61956	620 (70)	713a	61993b-c	155	1696
61887	256qqq	229	61957	620 (70)	713b	61993b-c	164	1696
61888	267p	349	61958	620 (70)	713c	61993d	—	1336
61889	54yy	84	61959	620 (70)	713d	61993e	—	1695
61890	267n	354	61960	620 (69)	712	61994a	332	3231
61891	256uuu	230	61961	269o	346	61994b-c	332	3239-3240
61892	256ppp	228	61962	54gg	161	61994d	—	1335
61893	267m*	342	61963	25a*	162a	61994e	332	3241
61894	267i	347	61964	25a**	162b	61995	50ss	132
61895	267o	352	61965	54tt	163	61996	135cc	124
61896	267g-h	350	61966	54ss	164a	61997	333	1333
61897	269k	351	61967	54ss	164b	61998	150	1239
61898	267e	353	61968	269a 5	363	61999	272a	448
61899	267k	368	61969	269a 1	364	62000	245	188
61900	256ooo	227	61970	269a 6	365	62001	242	187
61901	256vvv	231	61971	269a 3	366	62002	596a	734
61902a	256a	266	61972	269a 2	367	62003	415	539
61902b	256b	366	61973	620 (94)	707	62004	389	735
61903	256b	224	61974	44o	65	62005	599	1585
61904	46b	945	61975	54ddd 4	76	62006	600	1586
61905	46c	946	61976	54q	75	62007	175a-b	186
61906	54r	950	61977	256q	295	62008	50gg	125
61907	21u	948	61978	261l	356	62009	76	32
61908	53a	947	61979	267b	358	62010	75	31
61909	46qq	949	61980	—	1217	62011	35	732
61910	46r	951	61981	—	934	62012	137	221
61911	256gg	322	61982	44a	—	62013	73	521
61912	256h	323	61983	44a	—	62014	466	530
61913	256t	313	61984	44a	—	62015	377	1065
61914	256p	321	61985	50tt	—	62016	47	20
61915	256e	319	61986	50tt	—	62017	80	95
61916	269f	318	61987	58ss	—	62018	586	1187
61917	269g	312	61988	620 (50)	—	62018	600a-d	1187
61918	269lll	320	61989a	120	98-9	62019	64	505
61919	269q	965	61989a	120	102-3	62020	403c	533
61920	269fff	966	61989a	131	98-9	62021	403b	532
61921	269 4a	967	61989a	131	102-3	62022	403a	531
61922	269kk	968	61989a	136	98-9	62023	403d	534
61923	269ggg	969	61989a	136	102-3	62024	21c	88
61924	269hhh	970	61989b-c	zu 120	105-6	62025	101o	87
61925	269xxx	971	61989d	157	111	62026	547d	1225
61926	269yyy	972	61989e-f	152a-b	113-4	62027	548a	1226
61927	269 4b	973	61989g	120h	109	62028	91	1
61928	269xxx	974	61989h-i	122j	1236	62029	87	3
61929	44bb	761	61989j-k	122l	1238	62030	351	983
61930	44bb	760	61989l	120	933	62031	82	1579
61931	44cc	765	61989m	121z	1697	62032	349	563
61932	44cc	975	61990a	133-4	97	62033	39	22
61933	44dd	763	61990a	133-4	100-01	62034	457	756
61934	21y	762	61990a	133-4	104	62035	83	15
61935	525	1286	61990a	122	97	62036	140	1039
61936	21dd	764	61990a	122	100-01	62037	139	909
61937	256 4m	268	61990a	122	104	62038	467	550
61938	267m 2	362	61990b-c	122e	107-8	62039	74	25
61939	547b	1307	61990d	160	112	62040	84	26
61940	620 (123)	1310	61990e-f	162c-d	115-6	62041	81	24
61941	267i-j	345	61990g	122h	110	62042	149	1602
61941	267q	345	61990j	103a	1698	62043	412	549
61942	261p 2	369	61990h-i	122j	1237	62044	511	1582
61943	261p 3	370	61991a	103	1325	62045	378	982
61944	261p 1	374	61991a	121	1325	62046	90	2
61945	261i	375	61991b-c	107	1691	62047	30	901
61946	261o	376	61991d	—	1692	62048	88	4
61947	261n	371	61991h	122k	1694	62049	442b	1011
61948	261m	372	61991e-f	162a-b	1693	62050	592	1010
61948	269a 4	372	61991g	156	1699	62051	67	498

JE	Carter	Ausstellung	JE	Carter	Ausstellung	JE	Carter	Ausstellung
62052	92	23	62120	578	635	62191	620 (37)	553
62053	442c	1012	62121	420	627	62192	469	576
62054	414	1013	62122	584	545	62193	—	1345
62055	613	1301	62122	92e	144	62194	44s	142
62056	354	575	62123	520	543	62195	620 (35)	672
62057	33	900	62124	579	544	62196	620 (36)	673
62058a-o	345	540	62125	24	11	62197	271f	402
62058a-o	580	540	62126	45	34	62198	40a	136
62058a-o	46x	540	62127	435	548	62199	32j	138
62059	593	566	62128	475	546	62200	32k	139
62059	620 (110)	566	62129	344	547	62201	32l	137
62060	585r	542	62130	417	578	62202	54bbb	53
62061	393	541	62131	410n	574	62203	54oo	203
62062	—	709	62132	385	552	62204	54z	42
62063	—	1219	62133	449	923	62205	54aa	199
62064	620 (13)	726	62134	339	939	62206	54bb	200
62065	—	1214	62134	96a	939	62207	54cc	201
62066	—	1213	62135	407	583	62208	54dd	205
62067	—	1215	62136	408	621	62209	54g	210
62068	—	1218	62137	126	326	62210	54ii	198
62069	—	1220	62138	128	37	62211	54jj	212
62070	—	1221	62139	32e	1268	62212	54l	206
62071	—	1222	62140	32d	1269	62213	54ll	208
62072	620 (1)	1300	62141	485	988	62214	54mm	209
62073	389	829	62142	480	615	62215	54nn	204
62074	387	1350	62143	483	626	62216	54pp	211
62075	21ww	828	62144	588	564	62217	54x	202
62076	21xx	1349	62145	340	584	62218	69	207
62077	—	1194	62146	359	618	62219	620 (33)	570
62078	—	1193	62147	27	33	62220	461f	1018
62079	262	380	62148	130	325	62221	461g	1025
62080	271e 2	381	62149	524	620	62222	461h	650
62081	271b	382	62150	620 (122)	1248	62223	461i	1016
62082	442c	580	62151	7a	1282	62224	461j	651
62083	620 (44)	581	62152	7	1281	62225	461k	1026
62084	620 (93)	586	62153	20	1280	62226	461l	1017
62085	620 (92)	1004	62154	32b 4	1277	62227	461m	1024
62086	620 (90)	1002	62155	55	1283	62228	461n	1020
62087	367l	999	62156	353	987	62229	461o	1019
62088	620 (89)	1001	62157	59	10	62230	461q	652
62089	367m	1000	62158	16	35	62231	461c	1021
62090	620 (91)	1003	62159	32a 2	1284	62232	461e	1022
62091	585bb	998	62160	32a 2	1276	62233	461p	1023
62092	585bb	997	62161	32b 4	1278	62234	461a	647
62093	367n	577	62162	32b 4	1270	62235	461b	648
62094	271e 1	383	62163	32i	1279	62236	461d	649
62095	271g	379	62164	404	617	62237	461r	653
62096	620 (65)	1005	62165	124	38	62233	461s	654
62097	620 (85)	1267 (2)	62166	374	579	62239	461t	655
62098	620 (79)	1267 (3)	62167	127	36	62240	620 (31)	561
62099	620 (80)	1267 (1)	62168	583	587	62241	461w	657
62100	620 (83)	1267 (5)	62169	125	39	62242	461v	656
62101	620 (82)	1267 (6)	62170	423	582	62243	461x	646
62102	620 (81)	1267 (4)	62171	343	992	62244	620 (32)	562
62103	620 (86)	1267 (7)	62172	405	585	62245	461u	1015
62104	620 (106)	669	62173	421	1009	62246	461y	1014
62105	620 (108)	670	62174	482	616	62247	399a	572
62106	620 (109)	671	62175	479	991	62248	54ccc	40
62107	620 (96)	683	62176	448	990	62249	54w	43
62108	620 (100)	684	62177	603	989	62250	25	63
62109a	620 (105)	727	62178	32g	1271	62251	31a	61
62109b	43	1342	62179	604	1008	62252	31	60
62109b	522	1342	62180	—	1273	62253	63	62
62110	620 (101)	720	62181	32c	1274	62254	620 (29)	558
62111	173	184	62182	265a	398	62255	620 (30)	559
62112	174	182	62183	265b	399	62256	367d	567
62113	360	748	62184	265c	400	62257	54n	50
62114	210	185	62185	261h	394	62258	54qq**	47
62115	58	9	62186	261h	393	62259	54qq*	46
62116	57	6	62187	32f	1272	62260	54qq***	48
62117	61	8	62188	32h	1275	62261	54qq****	49
62118	60	7	62189	620 (2)	1299	62262	54t	51
62119	211	183	62190	394	554	62263	54u	52

JE	Carter	Ausstellung	JE	Carter	Ausstellung	JE	Carter	Ausstellung
62264	54h	41	62334	—	1675	62407	585a	598
62265	54rr*	44	62335	—	1329	62408	585c	600
62266	54rr**	45	62336	—	1330	62409	585f	603
62267	—	1240	62337	—	1331	62410	585c	602
62268	620 (34)	571	62338	304	1258	62411	585g	604
62269	—	1241	62339	302	1257	62412	585b	599
62270	177	501	62340	283	1256	62413	585d	601
62271	9	1223	62341	279	1255	62414	585h	605
62272	24	1287	62342	275	1254	62415	620 (44)	591
62273	23	1224	62343	272	1253	62416	620 (42)	592
62274	203	499	62344	271	1676	62417	620 (40)	590
62275	197	500	62345	—	—	62418	620 (39)	589
62276	406	986	62346	54ddd 5	71	62419	44ee	166
62277	—	1297	62347	54ddd 3	1040	62420	620 (38)	588
62278	614k	1296	62348	271c-d	378	62421	585k	595
62279	614a	1288	62349	269b	377	62422	585i	593
62280	614b	1289	62350	46jj	156	62423	585l	596
62281	614c	1290	62351	44y	155	62424	585j	594
62282	614e	1291	62352	54s	90	62425	585m	597
62283	614f	1292	62353	41	30	62426	585p	—
62284	614g	1293	62354	41	29	62427	585p	—
62285	614h	1294	62355	41	28	62428	585ff 5	242
62286	614i	1295	62356	41	27	62429	44d	69
62287	—	1298	62357	263	390	62430	44i	67
62288	106b	1302	62358	46r	157	62431	256ff 1	243
62289	15a	1303	62359	181	172	62432	256ff 4	244
62290	154	1332	62360	296n	360	62433	256vv 6	250
62291	32n	1305 (6)	62361	256gq	256	62434	256vv 8	251
62292	32n	1305 (5)	62362	256yy	257	62435	256vv 2	253
62293	32n	1305 (4)	62363	256zz	234	62436	44h	70
62294	32n	1305 (3)	62364	256pp	238	62437	44c	68
62295	32n	1305 (2)	62365	256rr	235	62438	256vv 1	255
62296	32n	1305 (1)	62366	256ww	239	62439	256vv 3	254
62297	86	1304	62367	256x	236	62440	256vv 4	246
62298	32m	1346	62368	256xx	237	62441	256vv 5	247
62299	503	1677	62369	256ss b	262	62442	256ff 3	241
62300	500	1677	62370	256ddd	261	62443	256bbb	245
62301	523	1678	62371	256ss	264	62444	44j	78
62302	490	1679	62372	256oo	263	62445	44e	72
62303	486	1680	62373	256aaa	260	62446	256ccc	249
62304	434	1681	62374	269g	357	62447	256vv 7	252
62305	392	1682	62375	620 (47)	721	62448	256ff 2	248
62306	413	1683	62376	620 (48)	722	62449	271h	361
62307	511	1684	62377	620 (49)	723	62450	44g	77
62308	560	1685	62378	620 (75)	725	62451	44f	73
62309	411	—	62379	620 (74)	724	62452	53b	1344
62310	541	—	62380	269m	359	62453	43k	1344
62311	539	—	62381	547c	1308	62453	367g	898
62312	(509)	1686	62382	256n	240	62454	620 (56)	1085 (88)
62313	508	1687	62383	256hh	290	62455	367g	1085 (105)
62314	206	503	62384	256uu	285	62456-64	620 (56)	1085 (76-84)
62315	195	502	62385	256hh 2	286	62465	620 (56)	886
62316	180	504	62386	256hh 3	287	62466	620 (56)	888
62317	489	1327	62387	256hh 1	288	62467	367g	896
62318	568	1328	62388	256www	289	62468	367g	1085 (104)
62319	563	—	62389	256jj 1	282	62469	620 (56)	895
62320	516	—	62390	256u	283	62470-96	620 (56)	1085 (49-75)
62321	—	—	62391	256v	284	62497	367g	1085 (102)
62322	549	—	62392	256jj 2	281	62498	367g	1085 (103)
62323	509	—	62393	256ccc	277	62499-	—	—
	oder 570	—	62394	256w	278	538	620 (56)	1085 (9-48)
62323	570	—	62395	256jj 3	279	62539	620 (56)	892
	oder 509	—	62396	256jj 4	280	62540-2	620 (56)	1085 (85-7)
62324	362	1306	62397	620 (46)	638	62543	620 (56)	885
62325	431	925	62398	270c	905	62544-9	367g	1085
62326	502	924	62399	585o	609			(106-11)
62327	105	—	62400	56a	167	62550	367g	897
62328	498	—	62401	92h	165	62551	367g	1085 (112)
62329	498	—	62402	620 (44)	610	62552	620 (56)	887
62330	409	—	62403	585n	608	62553	620 (56)	1085 (96)
62331	—	1688	62404	620 (45)	611	62554	620 (56)	1085 (92)
62332	—	1689	62405	620 (43)	607	62555	620 (56)	1085 (89)
62333	—	1690	62406	585q	606	62556	620 (56)	1085 (93)

JE	Carter	Ausstellung	JE	Carter	Ausstellung	JE	Carter	Ausstellung
62557	620 (56)	—	62654	46gg	1077	62714	573c	1580 (12)
62558-61	367g	1085	62655	—	1192	62715	348	1580 (15)
	(98-101)		62656	50a	1668	62715	356	1580 (15)
62562-9	620 (56)	1085 (1-8)	62657	50j	—	62715	368	1580 (15)
62570-1	620 (56)	889-90	62658	101u	—	62715	400	1580 (15)
62572-3	367g	1085	62659	50p	—	62715	484	1580 (15)
		(113-4)	62660	50o	—	62715	527b	1580 (15)
62574-5	620 (56)	893-4	62661	50h	—	62716	364	1580 (13)
62576-7	620 (56)	1085	62662	101s	1665	62716	371	1580 (13)
		(94-5)	62663	44b	1662	62716	451	1580 (13)
62578	620 (56)	1085 (90)	62664	21pp	941	62716	518b	1580 (13)
62579	620 (56)	1085 (91)	62665	50m	757	62717	348	1580 (7)
62580	620 (56)	1085 (97)	62666	50s	1667	62717	400	1580 (7)
62581	620 (104)	3257	62667	50r	758	62718	589	1580 (8)
62582	620 (107)	3258	62668	43b	759	62718	591	1580 (8)
62583	620 (103)	3259	62669	50u	1648	62719	342	1580 (11)
62584	620 (97)	3260	62670	89a	1649	62719	441	1580 (11)
62585	620 (102)	3261	62671	21z	337	62719	506	1580 (11)
62586	620 (99)	3262	62672	43i-j	340	62719	562	1580 (11)
62587	620 (98)	3263	62673	44ff	338	62720	369	1580 (10)
62588	—	3244	62674	46cc	339	62720	426	1580 (10)
62589	—	3245	62675	367f	569	62720	429	1580 (10)
62590	302	1257	62676	46o	1042	62720	470	1580 (10)
62591-			62677	46p	1043	62720	527a	1580 (10)
602	—	3230-41	62678	79q (?)	745	62720	528	1580 (10)
62603	—	3243	62679	50p	1045	62720	530	1580 (10)
62604	—	3242	62680	21f-g	341	62720	542	1580 (10)
62605-8	—	3247-50	62681	21k-l	912-3	62720	544	1580 (10)
62609	—	3246	62682	270a-b	914-5	62720	567	1580 (10)
62610	—	3251	62683	436b	1259	62720	573b	1580 (10)
62611	—	3252	62684	21h-i	—	62721	365	1580 (9)
62612	279	1255	62685	397	565	62721	341	1580 (9)
62613	275	1254	62686	85	747	62721	347	1580 (9)
62614-5	—	3228-9	62686	147a	747	62721	372	1580 (9)
62616	272	1253b	62687	—	1263	62721	381	1580 (9)
62617	271	1252	62688	21a-b	910-1	62721	384	1580 (9)
62618	283	1256	62689	620 (119)	—	62721	396	1580 (9)
62619	272	1253a	62689	373	—	62721	416	1580 (9)
62620	304	1258		oder 453b	—	62721	419	1580 (9)
62621	—	3256	62689	453b	—	62721	427	1580 (9)
62622	—	3254		oder 373	—	62721	440a-c	1580 (9)
62623	—	3255	62690	620 (119)	—	62721	446	1580 (9)
62624	—	1669	62690	373	—	62721	450	1580 (9)
62625	367i	1666		oder 453b	—	62721	452	1580 (9)
62626	367j	642	62690	453b	—	62721	471	1580 (9)
62627	54k	515		oder 373	—	62721	472	1580 (9)
62628	587	1674	62691	—	1262	62721	474	1580 (9)
62629	44q	914	62692	367b	1261	62721	504	1580 (9)
62630	44q	938	62693	252	1227	62721	521	1580 (9)
62631	21t	746	62694	252	—	62721	532	1580 (9)
62632	21t	1646	62695	252a	—	62721	533	1580 (9)
62633	256eee	1211	62696	254b	—	62721	534	1580 (9)
62633	256nn	1211	62697	255b	—	62721	538	1580 (9)
62634	21d	1071	62698	256uuuu	1656	62721	553a-b	1580 (9)
62635	21d	1663	62699	256uuuu	—	62721	554	1580 (9)
62636	21w	1080	62700	256nnnn	1657	62721	555	1580 (9)
62637	54dd 2	1078	62701	50c	1664	62721	559a-b	1580 (9)
62638	456a	—	62702	288	—	62721	565	1580 (9)
62639	101p	1647	62703	291a	1230	62721	569	1580 (9)
62640	21bb	1081	62704	300a	1231	62721	573a	1580 (9)
62641	21x	1082	62705	281a	1229	62721	573d-e	1580 (9)
62642	21m	1083	62706	261a	1228	62722	32	1580 (14)
62643	21aa	937	62707	119c	1044	62723	526	1580 (6)
62644	21o	931	62708	50t	1046	62723	573f	1580 (6)
62645	21ff	932	62709	79c	1650	62723	616	1580 (6)
62646	21gg	1651	62710	620 (12)	644	62723a	115	—
62647	100f	1041	62711	620 (12)	645	62723a	317b	—
62648	21p	1072	62712	355	1580 (17)	62724	17	1660
62649	21q	1079	62712	401	1580 (17)	62725	18	1659
62650	21r	1073	62713	439	1580 (16)	62726	205	1658
62651	21aa	1075	62713	473	1580 (16)	62727	19a	509
62652	21jj	1076	62713	531	1580 (16)	62728	51	507
62653	44w	1074	62714	47b	1580 (12)	62729	198	1348

JE	Carter	Ausstellung	JE	Carter	Ausstellung	JE	Carter	Ausstellung
62730	142	508	29/3/34/09	43f	3299	29/3/34/58	50f	3385
62731	142	1580 (5)	29/3/			29/3/34/59	50n	3384
62732	—	1661	34/10a-b	43g	3308	29/3/		
62733	254a	1580 (1)	29/3/34/11	43h	3305	34/60a-c	79k	3356
62734	255a	1580 (4)	29/3/			29/3/		
62735	282a	1580 (3)	34/12a-e	43m	3296	34/61a-c	79l	3346
62736	297a	1580 (2)	29/3/34/13	43n	3307	29/3/		
62737	313	1580 (20)	29/3/34/14	43o	3309	34/62a-b	79u	3224
62738	313	1580 (22)	29/3/			29/3/		
62739	313	1580 (21)	34/15a-i	46d	3294	34/63a-b	101a	3336
62740	330	—	29/3/			29/3/		
62741	32t	749	34/16a-l	46e	3295	34/64a-b	101b	3333
62742	620	1267 (11)	29/3/			29/3/34/65	101f	3335
62743	—	1267 (8)	34/17a-i	46f	3302	29/3/		
62744	620 (88)	1267 (10)	29/3/			34/66a-b	101h	3332
62745a	209	1702	34/18a-g	46g	3314	29/3/		
62745b	209	1702	29/3/34/19	46l	3298	34/67a-c	101i	3329
62746	120	—	29/3/34/20	46uu	3313	29/3/		
62747	168	1670	29/3/			34/68a-c	101j	3334
62748	148a	1671	34/21a-c	50b	3326	29/3/		
62749	148b	1672	29/3/			34/69a-e	101k	3328
62750	148c	1673	34/22a-c	50f	3327	29/3/34/70	299a	3337
62751	34	—	29/3/			29/3/34/71	101v	3279
62752	—	1191	34/23a-e	50g	3304	29/3/34/72	21v	3379
62753	620	1267 (12)	29/3/			29/3/34/73	275b	3370
62754	44n	944	34/24a-ad	50l	3301	29/3/34/74	275c	3369
62755	—	—	29/3/			29/3/34/75	275d	3371
62756	—	1700	34/25a-i	50r	3303	29/3/34/76	275e	3368
62757	—	1343	29/3/34/26	79b	3300	29/3/34/77	280a	3367
62758	—	—	29/3/34/27	79m	3310	29/3/34/85	291a	3363
62759	—	—	29/3/			29/3/34/86	292a	3361
62760	—	—	34/28a-d	101c	3311	29/3/34/87	293a	3357
62761	—	—	29/3/			29/3/34/90	297a	3360
62762a	—	—	34/29a-f	101g	3306	29/3/34/92	300a	3362
62762b	—	—	29/3/			29/3/34/93	301a	3358
87847	?	?	34/30a-d	46i	3289	29/3/34/94	303a	3359
87848	?	?	29/3/			29/3/34/95	585x	3380
87849	?	?	34/31a-d	46j	3293	29/3/34/96	101r	3272
87850	?	?	29/3/			29/3/34/97	21tt	3284
87851	?	?	34/32a-f	46k	3292	29/3/34/98	44x	3280
87852	519c	?	29/3/			29/3/34/99	101d	3340
87853	602f	?	34/33a-o	50m	3288	29/3/		
87854	602f?	?	29/3/34/34	50r	3290	34/100a-o	101e	3353
87855a-b	?	?	29/3/34/35	101aa	3291	29/3/		
87856	?	?	29/3/34/36	21ii	3344	34/101a-i	79k	3355
87857	?	?	29/3/			29/3/		
27/3/34/01	85b	3165	34/37a-j	21qq	3325	34/102a-u	79l	3349
27/3/34/03	503?	3228	29/3/34/38	43d	3321	29/3/		
27/3/34/37	—	3107	29/3/			34/103a-e	21uu	3348
27/3/34/38	585p	1343	34/39a-e	43l	3317	29/3/34/104	46h	3339
28/3/	—	—	29/3/			29/3/34/105	21ss	3341
34/01-80	50yy	3190	34/40a-l	79o	3318	29/3/34/106	79j	3356
28/3/	—	—	29/3/			29/3/		
34/01-80	65a	3190	34/41a-e	79p	3321	34/107a-j	79d 1-10	3350
28/3/34/81	100e	3189	29/3/34/42	79t	3316	30/3/34/01	79n	3352
28/3/34/82	46a 1	3185	29/3/			30/3/		
28/3/	—	—	34/43a-d	79u	3323	34/02a-ai	79i	3354
34/90-101	148/149	3193	29/3/34/44	79u 2	3322	30/3/34/03	46mm	3351
28/3/	—	—	29/3/			30/3/		
34/102-8	147c	3192	34/45a-b	585x	3319	34/04a-h	21hh	3347
28/3/	—	—	29/3/34/46	101l	3320	30/3/34/05	79s	3283
34/109-17	50yy	3191	29/3/34/47	271e	3315	30/3/34/06	43v	3345
28/3/	—	—	29/3/34/48	101z	3343	30/3/34/07	54d	3265
34/109-17	65a	3191	29/3/34/49	100h	3342	30/3/34/07	54o	3265
29/3/34/01	44t	3238	29/3/34/50	21ee	3273	30/3/34/08	54i	3266
29/3/34/02	44r	3264	29/3/34/51	21ll	3281	30/3/34/09	46nn	3267
29/3/34/03	21cc	3274	29/3/34/52	21xx	3331	30/3/34/10	92g	3268
29/3/34/04	44t	3275	29/3/34/53	46tt	3330	30/3/34/11	—	3269
29/3/34/05	54f	3287	29/3/			30/3/34/12	79r	3270
29/3/34/06	44jj	3276	34/54a-c	50c	3338	30/3/34/13	21vv	3271
29/3/34/07	21nm	3297	29/3/34/55	50d	3386	30/3/34/14	44dd	3278
29/3/	—	—	29/3/34/56	50f	3382	30/3/34/15	79u 8	3282
34/08a-g	43c	3312	29/3/34/57	50f	3383	30/3/34/16	89b	3285

JE	Carter	Ausstellung	JE	Carter	Ausstellung	JE	Carter	Ausstellung
30/3/34/17	43e	3286	30/3/34/29	453b	3397	30/3/34/39	620 (119)	3407
30/3/34/18	54v	3277	30/3/34/29	620 (119)	3397	30/3/34/40	373	3408
30/3/34/19	373	3387	30/3/34/30	373	3398	30/3/34/40	453b	3408
30/3/34/19	453b	3387	30/3/34/30	453b	3398	30/3/34/40	620 (119)	3408
30/3/34/19	620 (119)	3387	30/3/34/30	620 (119)	3398	30/3/34/41	373	3409
30/3/34/20	373	3388	30/3/34/31	373	3399	30/3/34/41	453b	3409
30/3/34/20	453b	3388	30/3/34/31	453b	3399	30/3/34/41	620 (119)	3409
30/3/34/20	620 (119)	3388	30/3/34/31	620 (119)	3399	30/3/34/42	373	3410
30/3/34/21	373	3389	30/3/34/32	373	3400	30/3/34/42	453b	3410
30/3/34/21	453b	3389	30/3/34/32	453b	3400	30/3/34/42	620 (119)	3410
30/3/34/21	620 (119)	3389	30/3/34/32	620 (119)	3400	30/3/34/43	373	3411
30/3/34/22	373	3390	30/3/34/33	373	3401	30/3/34/43	453b	3411
30/3/34/22	453b	3390	30/3/34/33	453b	3401	30/3/34/43	620 (119)	3411
30/3/34/22	620 (119)	3390	30/3/34/33	620 (119)	3401	30/3/34/44	373	3412
30/3/34/23	373	3391	30/3/34/34	373	3402	30/3/34/44	453b	3412
30/3/34/23	453b	3391	30/3/34/34	453b	3402	30/3/34/44	620 (119)	3412
30/3/34/23	620 (119)	3391	30/3/34/34	620 (119)	3402	30/3/34/45	104a	3413
30/3/34/24	373	3392	30/3/34/35	373	3403	30/3/34/46	585x	3381
30/3/34/24	453b	3392	30/3/34/35	453b	3403	30/3/34/47	—	3414
30/3/34/24	620 (119)	3392	30/3/34/35	620 (119)	3403	30/3/34/47	172	3414
30/3/34/25	373	3393	30/3/34/36	373	3404	30/3/34/51	21	—
30/3/34/25	453b	3393	30/3/34/36	453b	3404	30/3/34/51	21d	—
30/3/34/25	620 (119)	3393	30/3/34/36	620 (119)	3404		oder e	—
30/3/34/26	373	3394	30/3/34/37	373	3405	30/3/34/51	25b	—
30/3/34/26	453b	3394	30/3/34/37	453b	3405	30/3/34/51	79f	—
30/3/34/26	620 (119)	3394	30/3/34/37	620 (119)	3405	30/3/34/51	79h	—
30/3/34/27	94a	3395	30/3/34/38	373	3406	30/3/34/51	100g	—
30/3/34/28	373	3396	30/3/34/38	453b	3406	30/3/34/51	101q	—
30/3/34/28	453b	3396	30/3/34/38	620 (119)	3406	30/3/34/51	317b 2	—
30/3/34/28	620 (119)	3396	30/3/34/39	373	3407	30/3/34/52	122a-rrrr	—
30/3/34/29	373	3397	30/3/34/39	453b	3407			

KONKORDANZ NACH CARTER-NUMMERN

Carter	Ausstellung	JE	Carter	Ausstellung	JE	Carter	Ausstellung	JE
entfällt	entfällt	61469	—	1313	61404	21	—	30/3/34/51
?	?	62755	—	1314	61400	21	324	61467
?	?	S-4455	—	1317	61418	21a-b	910-1	62688
?	?	S-4457-63	—	1329	62335	21c	88	62024
?	?	87847	—	1330	62336	21d	1071	62634
?	?	87848	—	1331	62337	21d	1663	62635
?	?	87849	—	1334	61992d	21d oder e	—	30/3/34/51
?	?	87850	—	1335	61994d	21f-g	341	62680
?	?	87851	—	1336	61993d	21h-i	—	62684
?	?	87855a-b	—	1337	61459	von 21j?	?	S-4456
?	?	87856	—	1339	61460	21k-l	912-3	62681
?	?	87857	—	1343	62757	21m	1083	62642
?	—	S-4474	—	1345	62193	21o	931	62644
?	—	S-4488	—	1604	61749	21p	1072	62648
?	—	S-4499	—	1630	61646	21q	1079	62649
?	3049	61397	—	1661	62732	21r	1073	62650
—	—	62758	—	1669	62624	von 21s?	—	S-4466
—	—	62759	—	1675	62334	21t	746	62631
—	—	62760	—	1688	62331	21t	1646	62632
—	—	62761	—	1689	62332	21u	948	61907
—	—	S-4494	—	1690	62333	21v	3379	29/3/34/72
—	—	62321	—	1692	61991d	21w	1080	62636
—	—	62345	—	1695	61993e	21x	1082	62641
—	—	62762a	—	1700	62756	21y	762	61934
—	—	62762b	—	3043	61427	21z	337	62671
—	117	61586	—	3044	61443	21aa	937	62643
—	118	61587	—	3054	61440	21aa	1075	62651
—	525	61731	—	3055	61424	21bb	1081	62640
—	526	61626	—	3056	61428	21cc	3274	29/3/34/03
—	527	61632	—	3084	61430	21dd	764	61936
—	528	61634	—	3107	27/3/34/37	21ee	3273	29/3/34/50
—	529	61729	—	3228-9	62614-5	21ff	932	62645
—	709	62062	—	3230-41	62591-602	21gg	1651	62646
—	927a	61575	—	3242	62604	21hh	3347	30/3/34/04a-h
—	927b	61574	—	3243	62603	21ii	3344	29/3/34/36
—	934	61981	—	3244	62588	21jj	1076	62652
—	981	61625	—	3245	62589	21ll	3281	29/3/34/51
—	1191	62752	—	3246	62609	21nn	3297	29/3/34/07
—	1192	62655	—	3247-50	62605-8	21pp	941	62664
—	1193	62078	—	3251	62610	21qq	3325	29/3/34/37a-j
—	1194	62077	—	3252	62611	21ss	3341	29/3/34/105
—	1213	62066	—	3254	62622	21tt	3284	29/3/34/97
—	1214	62065	—	3255	62623	21uu	3348	29/3/34/103a-e
—	1215	62067	—	3256	62621	21vv	3271	30/3/34/13
—	1216	60947	—	3269	30/3/34/11	21ww	828	62075
—	1217	61980	—	3414	30/3/34/47	21xx	1349	62076
—	1218	62068	von den	—	—	21xx	3331	29/3/34/52
—	1219	62063	Schreinen	—	S-4486	22	96	60707
—	1220	62069	von Wagen	—	—	23	1224	62273
—	1221	62070	'C'?	—	S-4490	24	11	62125
—	1222	62071	(13 ?)5vv	—	61675	24	1287	62272
—	1240	62267	—	—	—	25	63	62250
—	1241	62269	1k	1243	61500a-b	25a*	162a	61963
—	1262	62691	7	1281	62152	25a**	162b	61964
—	1263	62687	7a	1282	62151	25b	—	30/3/34/51
—	1264a	61883	8	755	60723	25o	192	61785
—	1264b	61882	9	1223	62271	26	513	61382
—	1265a	61283	14a	91	61465	27	33	62147
—	1265b	61284	14b	93	61493	29	181	60708
—	1265c	61285	15a	1303	62289	30	901	62047
—	1265d	61286	16	35	62158	31	60	62252
—	1267 (8)	62743	17	1660	62724	31a	61	62251
—	1273	62180	18	1659	62725	32	5	61445
—	1297	62277	19a	509	62727	32	1580 (14)	62722
—	1298	62287	20	1280	62153	von 32?	—	S-4470

Carter	Ausstellung	JE	Carter	Ausstellung	JE	Carter	Ausstellung	JE
32a 2	1276	62160	44d	69	62429	48c	179	61736
32a 2	1284	62159	44e	72	62445	48d	176	61733
32b 4	1270	62162	44f	73	62451	48e	130	61713
32b 4	1277	62154	44g	77	62450	48e (1?)	1589	61504
32b 4	1278	62161	44h	70	62436	48f	520	61545
32c	1274	62181	44i	67	62430	48g	523	61524
32d	1269	62140	44j	78	62444	48g	3113	61520
32e	1268	62139	44k	82	61873	48h	120	61517
32f	1272	62187	44l	79	61872	48i (1)	127	61544
32g	1271	62178	44n	944	62754	48i (2)	119	61537
32h	1275	62188	44o	65	61974	48j (1)	128	61525
32i	1279	62163	44p	151	61294	48j (2)	524	61533
32j	138	62199	44q	914	62629	48k (1)	121	61526
32k	139	62200	44q	938	62630	48l	522	61523
32l	137	62201	44r	3264	29/3/34/02	48m	—	61637
32m	1346	62298	44s	142	62194	48n	—	61676
32n	1305 (1)	62296	44t	3238	29/3/34/01	48o	—	61678
32n	1305 (2)	62295	44t	3275	29/3/34/04	48p	1628	61672
32n	1305 (3)	62294	44u	86	61762	48q	1625	61699
32n	1305 (4)	62293	44v	150	61293	48r (?)	—	61683
32n	1305 (5)	62292	44w	1074	62653	48s	1627	61702
32n	1305 (6)	62291	44x	3280	29/3/34/98	48t	—	61684
32o	152a	61266	44y	155	62351	48u	—	61685
32o	152b	61267	44bb	760	61930	48v	1626	61703
32o	152c	61268	44bb	761	61929	48w	1629	61701
32o	152d	61269	44cc	765	61931	48x	926	61570
32p	153a	61272	44cc	975	61932	48y	—	61561
32p	153b	61273	44dd	763	61933	50	94	61454
32r	511	61390	44dd	3278	30/3/34/14	50—?	1645	61633
32t	749	62741	44ee	166	62419	50a	1668	62656
33	900	62057	44ff	338	62673	50b	3326	29/3/34/21a-c
34	—	62751	44gg	81	61874	50c	1664	62701
35	732	62011	44jj	3276	29/3/34/06	50c	3338	29/3/34/54a-c
von 35	—	S-4483	45	34	62126	50d	3386	29/3/34/55
37	18	60751	46a 1	3185	28/3/34/82	50f	3327	29/3/34/22a-c
37a	19	60750	46a 2	—	61563	50f	3382	29/3/34/56
38	333	60753	46a 3	—	61562	50f	3383	29/3/34/57
38a	332	60752	46b	945	61904	50f	3385	29/3/34/58
39	22	62033	von 46b ?	945	S-4472	50g	3304	29/3/34/23a-e
39q	154a	61274	46c	946	61905	50h	—	62661
39q	154b	61275	von 46c ?	946	S-4465	50j	—	62657
39q	154c	61276	46d	3294	29/3/34/15a-i	50l	3301	29/3/34/24a-ad
39q	154d	61277	46e	3295	29/3/34/16a-l	50m	757	62665
39q	154e	61278	46f	3302	29/3/34/17a-i	50m	3288	29/3/34/33a-o
40	12	61466	46g	3314	29/3/34/18a-g	50n	3384	29/3/34/59
40a	136	62198	46h	3339	29/3/34/104	50o	—	62660
41	27	62356	46i	3289	29/3/34/30a-d	50p	—	62659
41	28	62355	46j	3293	29/3/34/31a-d	50p	1045	62679
41	29	62354	46k	3292	29/3/34/32a-f	50r	758	62667
41	30	62353	46l	3298	29/3/34/19	50r	3290	29/3/34/34
42	173	61381	von 46n ?	944	S-4476	50r	3303	29/3/34/25a-i
43	1342	61480	46o	1042	62676	50s	1667	62666
43	1342	62109b	46p	1043	62677	50t	1046	62708
43b	759	62668	46r	157	62358	50u	1648	62669
43c	3312	29/3/34/08a-g	46r	951	61910	50v	—	61628
43d	3321	29/3/34/38	46x	540	62058a-o	50y	1643	61635
43e	3286	30/3/34/17	46y	159	61833	50aa	—	61630
43f	3299	29/3/34/09	46aa	146	61321	50cc	1642	61636
43g	3308	29/3/34/10a-b	46cc	339	62674	50dd	54	61320
43h	3305	29/3/34/11	46gg	1077	62654	50dd**	55	61315
43i-j	340	62672	46jj	156	62350	50ee*	56	61316
43k	1344	62452	von 46kk ?	—	S-4477	50ee**	57	61317
43l	3317	29/3/34/39a-e	46mm	3351	30/3/34/03	50ff**	58	61318
43m	3296	29/3/34/12a-e	46nn	3267	30/3/34/09	50ff**	59	61319
43n	3307	29/3/34/13	46qq	949	61909	50gg	125	62008
43o	3309	29/3/34/14	von 46qq ?	949	S-4469	50jj	133	61673
43v	3345	30/3/34/06	von 46rr ?	957	S-4473	50ll	—	61627
44	13	61476	46tt	3330	29/3/34/53	50mm	—	61629
44a	—	61982	46uu	3313	29/3/34/20	50nn	129	61754
44a	—	61983	47	20	62016	50oo	122	61727
44a	—	61984	47b	1580 (12)	62714	50pp	126	61638
44b	1662	62663	48a	180	61737	50qq	—	61723
44c	68	62437	48b	178	61735	50ss	132	61995

Carter	Ausstellung	JE	Carter	Ausstellung	JE	Carter	Ausstellung	JE
50tt	—	61985	57	6	62116	79p	3321	29/3/34/41a-e
50tt	—	61986	58	9	62115	79q (?)	745	62678
50uu	175	61732	58ss	—	61987	79r	3270	30/3/34/12
50ww	1624	61700	59	10	62157	79s	3283	30/3/34/05
50xx	134	61653	60	7	62118	79t	3316	29/3/34/42
50yy	3190	28/3/34/01-80	61	8	62117	79u	3224	29/3/34/62a-b
50yy	3191	28/3/34/109-17	62a	3080	61402	79u	3323	29/3/34/43a-d
50zz?	1644	61631	62b	1316	61409	79u 2	3322	29/3/34/44
51	507	62728	62b?	3083	61431	79u 8	3282	30/3/34/15
von 53?	947	S-4467	62d	3062	61407	80	95	62017
von 53?	947	S-4468	62e	3073	61410	81	24	62041
53a	947	61908	62f	3053	61416	82	1579	62031
53b	1344	62452	62g	3082	61432	83	15	62035
54	917	61452	62j	3050	61396	84	26	62040
54c	147	61281	62l	3071	61411	85	747	62686
54d	141	61615a	62m	3045	61417	85b	3165	27/3/34/01
54d	3265	30/3/34/07	62n	3077	61412	86	1304	62297
54e	140	61617	62o	3057	61423	87	3	62029
54f	3287	29/3/34/05	62q	3065	61406	88	4	62048
54g	210	62209	62r	3069	61429	89a	1649	62670
54h	41	62264	62s	3052	61408	89b	3285	30/3/34/16
54i	143	61325	62t	3058	61413	90	2	62046
54i	3266	30/3/34/08	62u	3047	61441	91	1	62028
54k	515	62627	62u	3067	61420	92	23	62052
54l	206	62212	62v	3074	61426	92e	144	62122
54n	50	62257	62? w	3048	61398	92g	3268	30/3/34/10
54o	3265	30/3/34/07	62w	3046	61442	92h	165	62401
54q	75	61976	62y	3081	61433	93	1635	61386
54r	950	61906	62aa	3075	61422	94a	3395	30/3/34/27
von 54r?	950	S-4464	62cc	3063	61437	94b	149	61169
54s	90	62352	62dd	1318	61403	95	131	61715
54t	51	62262	62ee	3072	61421	96a	939	62134
54u	52	62263	62ff	3059	61419	97	174	61391
54v	3277	30/3/34/18	62ff	3078	61405	98	123	61730
54w	43	62249	62gg	3064	61436	99a	160	61790
54x	202	62217	62ii	3060	61438	100a	177	61734
54z	42	62204	62ll	3061	61439	100e	3189	28/3/34/81
54aa	199	62205	62oo	3070	61415	100f	1041	62647
54bb	200	62206	62qq	3079	61425	100g	—	30/3/34/51
54cc	201	62207	62rr	3076	61414	100h	3342	29/3/34/49
54dd	205	62208	62ss	1315	61401	100i?	519	61738
54dd 2	1078	62637	62tt	3068	61434	101	21	61468
54ee	64	60719	62vv	3066	61435	101a	3336	29/3/34/63a-b
54ff	74	60718	62? ww	3051	61399	101b	3333	29/3/34/64a-b
54gg	161	61962	63	62	62253	101c	3311	29/3/34/28a-d
54hh	92	61498	64	505	62019	101d	3340	29/3/34/99
54ii	198	62210	65a	3190	28/3/34/01-80	101e	3353	29/3/34/100a-o
54jj	212	62211	65a	3191	28/3/34/109-117	101f	3335	29/3/34/65
54ll	208	62213	67	498	62051	101g	3306	29/3/34/29a-f
54mm	209	62214	68	921	61455	101h	3332	29/3/34/66a-b
54nn	204	62215	69	207	62218	101i	3329	29/3/34/67a-c
54oo	203	62203	70	1594	61512	101j	3334	29/3/34/68a-c
54pp	211	62216	73	521	62013	101k	3328	29/3/34/69a-e
54qq*	46	62259	74	25	62039	101l	3320	29/3/34/46
54qq**	47	62258	75	31	62010	101o	87	62025
54qq***	48	62260	76	32	62009	101p	1647	62639
54qq****	49	62261	77a	1590	61503	101q	—	30/3/34/51
54rr*	44	62265	77b	3141	61519	101r	3272	29/3/34/96
54rr**	45	62266	79	750	61495	101s	1665	62662
54ss	164a	61966	79b	3300	29/3/34/26	101u	—	62658
54ss	164b	61967	79c	1650	62709	101v	3279	29/3/34/71
54t	163	61965	79d 1-10	3350	29/3/34/107a-j	101w	943	61950
54vv	80	60717	79f	—	30/3/34/51	101z	3343	29/3/34/48
54yy	84	61889	79h	—	30/3/34/51	101aa	3291	29/3/34/35
54bbb	53	62202	79i	3354	30/3/34/02a-ai	103	1325	61991a
54ccc	40	62248	79j	3356	29/3/34/106	103a	1698	61990j
54ddd	89	61449	79k	3355	29/3/34/101a-i	104a	3413	30/3/34/45
54ddd 3	1040	62347	79k	3356	29/3/34/60a-c	105	—	62327
54ddd 4	76	61975	79l	3346	29/3/34/61a-c	106a	145	61170
54ddd 5	71	62346	79l	3349	29/3/34/102a-u	106b	1302	62288
55	1283	62155	79m	3310	29/3/34/27	107	1691	61991b-c
56	1341	61448	79n	3352	30/3/34/01	108	14	61481
56a	167	62400	79o	3318	29/3/34/40a-l	108a	506	61481

Carter	Ausstellung	JE	Carter	Ausstellung	JE	Carter	Ausstellung	JE
108c	85	61952	142	508	62730	207	1322	60664
110	17	60825	142	1580 (5)	62731	von 207 ?	—	S-4487
115	—	62723a	146	510	61390	208	1323	60665
115	918	61494	147a	747	62686	209	1702	62745a
116	16	60722	147c	3192	28/3/34/102-8	209	1702	62745b
117	1636	61387	147d	148	61289	210	185	62114
119	512	61382	148a	1671	62748	211	183	62119
119c	1044	62707	148b	1672	62749	212	—	61757
120	—	62746	148c	1673	62750	213	213	61742
120	98-9	61989a	148/149	3193	28/3/34/90-101	214a	—	61704
120	102-3	61989a	149	1602	62042	214b	—	61680
120	933	61989l	150	1239	61998	215	—	61758
zu 120	105-6	61989b-c	152a-b	113-4	61989e-f	216a	1612	61719
120h	109	61989g	153	3117	61522	216b	1613	61717
121	1325	61991a	154	1332	62290	217a	1616	61768
121z	1697	61989m	155	1696	61993b-c	217b	955	61669
122	97	61990a	156	1699	61991g	218	218	61624
122	100-1	61990a	157	111	61989d	219	1617	61767
122	104	61990a	von	—	—	221	1618	61668
122e	107-8	61990b-c	158o (6)	—	S-4496	222	832	61510
122h	110	61990g	von	—	—	223a	1615	61772
122j	1236	61989h-i	158o (9)	—	S-4493	223b	954	61773
122j	1237	61990h-i	von	—	—	224	197	61674
122k	1694	61991h	158o (10)	—	S-4492	225a	1593	61514
122l	1238	61989j-k	von	—	—	225b	1592	61513
122a-rrrr	—	30/3/34/52	158o (11)	—	S-4498	226	833	61508
124	38	62165	von	—	—	227a	191	61756
125	39	62169	158o (12)	—	S-4495	227b	190	61755
126	326	62137	von	—	—	227c	189	61753
127	36	62167	158o (15)	—	S-4497	227d	214	61743
128	37	62138	von	—	—	227e	215	61726
129	1637	61388	158o (19)	—	S-4500	228	830	61505
130	325	62148	160	112	61990d	229	514	61728
131	98-9	61989a	161	1324	61993a	230	1620	61724
131	102-3	61989a	162a-b	1693	61991e-f	231a	1611	61718
133-4	97	61990a	162c-d	115-6	61990e-f	231b	1614	61716
133-4	100-1	61990a	163	1324	61993a	232	953	61766
133-4	104	61990a	164	1696	61993b-c	233	217	61623
135-?	—	61706	168	1670	62747	234	1595	61509
135a	—	61693	172	3414	30/3/34/47	235a	195	61665
135b	—	61688	173	184	62111	235a	1188	60669
135c	—	61692	174	182	62112	235b	196	61666
135e	—	61696	175a-b	186	62007	236	1619	61765
135f	—	61691	176	194	60755	237	1321	60666
135g	—	61695	177	501	62270	237a	1249	60666
135i	—	61721	180	504	62316	238	1320	60667
135j	—	61689	181	172	62359	238a	1250	60667
135k	—	61694	182	487	61373	239	1319	60668
135l	—	61707	183	488	61372	240 bis	223	61496
135m	—	61690	184	489	61371	241	831	61515
135n	—	61708	185	490	61370	242	187	62001
135o	—	61705	186	491	61369	243	834-9	61560
135p	—	61697	187	492	61368	244	1588	61507
135q	979	61682	188	493	61367	245	188	62000
135r	—	61687	189	494	61366	246	1591	61511
135s	—	61770	190	495	61365	247	1212	61547
135t	—	61720	191	496	61364	247	1587	61506
135u	—	61686	192	497	61363	248	834-9	61560
135v	—	61725	193	193	61489	252	—	62694
135w	—	61722	von 193 ?	—	S-4471	252	1227	62693
135x	1621	61769	194	435	61374	252a	—	62695
135y	—	61677	195	502	62315	254	222	60670
135z	3110	61527	196	168	61777	254	936	60670
135aa	135	61741	197	500	62275	254a	1580 (1)	62733
135cc	124	61996	198	1348	62729	254b	—	62696
136	98-9	61989a	199	169	61776	255	219	60671
136	102-3	61989a	200	170	61775	255	935	60671
137	221	62012	201	171	61774	255a	1580 (4)	62734
138	158a	61850	202	436	61375	255b	—	62697
138	158b	61851	203	499	62274	256a	220	60672
138	158c	61849	204	216	61667	256a	266	61902a
139	909	62037	205	1658	62726	256b	224	61903
140	1039	62036	206	503	62314	256b	336	60673

Carter	Ausstellung	JE	Carter	Ausstellung	JE	Carter	Ausstellung	JE
256b	366	61902b	256iii	299	61837	266	456	60686
256c	297	61839	256iii 3	291	61852	266	457	60686
256d	311	61835	256jjj	300	61836	266	458	60686
256e	319	61915	256kkk	309	61841	266	985	60686
256h	323	61912	256lll*	327	60678	266a	455	60686
256i	517	61878	256lll**	327	60679	266a	456	60686
256i 2	976	61879	256lll**	327	60678	266a	457	60686
256j	270	60685	256lll**	327	60679	266a	458	60686
256k	226	61585	256mmm	315	61876	266a	985	60686
256l	334	60677	256nnn	316	61875	266b	984	60687
256m	298	61838	256ooo	227	61900	266c-f	437-40	60687
256n	240	62382	256ppp	228	61892	266c-f	1251	60687
256p	321	61914	256qqq	229	61887	von 266g	—	S-4478
256q	295	61977	256rrr	232	61951	von 266g	—	S-4479
256r	317	60684	256ttt	310	61840	von 266g	—	S-4480
256s	317	60684	256uuu	230	61891	von 266g	—	S-4481
256t	313	61913	256vvv	231	61901	von 266g	—	S-4482
256u	283	62390	256www	289	62388	266g	452	60688
256v	284	62391	256xxx	273	61865	266g	1184	60689
256w	278	62394	256yyy	275	61864	266g	1185	60690
256x	236	62367	256zzz	269	61848	266g	1186	60691
256z	314	61877	256 4a	274	61863	267	397	61462
256aa*	518	61880	256 4b	272	61861	267a	348	61886
256aa**	516	61881	256 4f	308	61855	267b	358	61979
256dd	225	61584	256 4g	301	61856	267c	355	61497
256ee	335	60676	256 4h	303	61847	267d	343	61884
256ff1	243	62431	256 4i	305	61843	267e	353	61898
256ff2	248	62448	256 4i bis	302	61844	267f	392	60757
256ff3	241	62442	256 4j	306	61846	267g-h	350	61896
256ff4	244	62432	256 4k	307	61854	267i	347	61894
256gg	322	61911	256 4l	304	61845	267i-j	345	61941
256hh	290	62383	256 4m	268	61937	267i u. 1	344	61885
256hh 1	288	62387	256 4n	1657	62700	267k	368	61899
256hh 2	286	62385	256 4o	317	60684	267m 2	362	61938
256hh 3	287	62386	256 4p	259	60675	267m*	342	61893
256jj 1	282	62389	256 4q	233	61853	267n	354	61890
256jj 2	281	62392	256 4r	292	61842	267o	352	61895
256jj 3	279	62395	256 4s	258	60674	267p	349	61888
256jj 4	280	62396	256 4u	—	62699	267q	345	61941
256kk	294	61778	256 4u	1656	62698	268	453	61461
256ll**	328	60680	256 4v	296	61869	269	396	61490
256ll***	329	60681	257	1232	61378	269a	1340	61463
256ll****	330	60682	258	1233	61376	269a 1	364	61969
256ll*****	331	60683	259	1234	61377	269a 2	367	61972
256nm	1211	62633	260	1235	61379	269a 3	366	61971
256oo	263	62372	261	447	61444	269a 4	372	61948
256pp	238	62364	261a	1228	62706	269a 5	363	61968
256qq	256	62361	261e	389a	61807	269a 6	365	61970
256rr	235	62365	261e	389b	61808	269b	377	62349
256ss	264	62371	261f	385	61859	269d	403	61763
256ss b	262	62369	261f	386	60946	269e	404	61760
256uu	285	62384	261f	387	60744	269f	318	61916
256vv 1	255	62438	261g	388	60743	269f	405	61761
256vv 2	253	62435	261g	391	60756	269g	312	61917
256vv 3	254	62439	261h	393	62186	269g	357	62374
256vv 4	246	62440	261h	394	62185	269h	406	61764
256vv 5	247	62441	261i	375	61945	269k	351	61897
256vv 6	250	62433	261j	373	61949	269m	359	62380
256vv 7	252	62447	261k	384	61783	269o	346	61961
256vv 8	251	62434	261l	356	61978	269q	965	61919
256ww	239	62366	261m	372	61948	269kk	968	61922
256xx	237	62368	261n	371	61947	269fff	966	61920
256yy	257	62362	261o	376	61946	269ggg	969	61923
256zz	234	62363	261p 1	374	61944	269hhh	970	61924
256aaa	260	62373	261p 2	369	61942	269lll	320	61918
256bbb	245	62443	261p 3	370	61943	269xxx	971	61925
256ccc	249	62446	262	380	62079	269xxx	974	61928
256ccc	277	62393	263	390	62357	269yyy	972	61926
256ddd	261	62370	264	395	60736	269 4a	967	61921
256eee	1211	62633	265a	398	62182	269 4b	973	61927
256fff	276	61834	265b	399	62183	270	902	61501
256ggg	271	61860	265c	400	62184	270	903	61471
256hhh	293	61779	266	455	60686	270a-b	914-5	62682

Carter	Ausstellung	JE	Carter	Ausstellung	JE	Carter	Ausstellung	JE
270b	1340	61463	297a	1580 (2)	62736	319k	1103	60942
270c	905	62398	297a	3360	29/3/34/90	319l	795	60943
271	451	61458	298a	429	60745	319m	1113	60875
271	1252	62617	299a	420	60735	319n	804	60896
271	1676	62344	299a	3337	29/3/34/70	319o	1111	60907
271a	401	61380	300a	428	60749	320	470	60697
271b	382	62081	300a	1231	62704	320a	470	60698
271c-d	378	62348	300a	3362	29/3/34/92	320b	442	60699
271e	3315	29/3/34/47	301a	416	60726	320c	445	60702
271e 1	383	62094	301a	3358	29/3/34/93	320d	443	60700
271e 2	381	62080	302	1257	62339	320e	444	60701
271f	402	62197	302	1257	62590	321	450	61330
271g	379	62095	302a	413	60729	322	1631	61484
271h	361	62449	303a	431	60741	322a	767	61023
272	920	61470	303a	3359	29/3/34/94	322b	1126	61007
272	1253	62343	304	1258	62338	322c	1127	61008
272	1253a	62619	304	1258	62620	322d	1131	61009
272	1253b	62616	304a	412	60730	322e	1134	60990
272a	448	61999	304b	414	60728	322f	1133	60991
273	3098	61341	305a	421	60725	322g	1136	61041
274	919	61324	306	485	61338	322h	773	61042
274	1037	61323	307	3106	61346	322i	768	61019
275	1254	62342	307f	634	61611	322j	774	61039
275	1254	62613	308	482	61347	323a	784	60855
275a	423	60732	309	483	61335	323b	1107	60856
275b	411	60712	310	484	61339	323c	783	60863
275b	3370	29/3/34/73	311	481	61344	323d	805	60858
275c	407	60709	312	1035	61348	323e	785	60862
275c	3369	29/3/34/74	313	471	61350	323f	786	60861
275d	995	60713	313	1580 (20)	62737	323g	1099	60870
275d	3371	29/3/34/75	313	1580 (21)	62739	323h ?	1100	60871
275e	994	60710	313	1580 (22)	62738	323i	1096	60872
275e	3368	29/3/34/76	314	486	61336	323j ?	1097	60864
276	3103	61329	315	1048	61473	323k ?	788	60869
277	922	61327	316	916	61474	323l	797	60852
279	1047	61472	316a	1195	61295	323m ?	1091	60853
279	1255	62341	316b	1196	61296	323n	787	60851
279	1255	62612	316c	1197	61297	323o	803	60930
279a	446	61326	316d	1198	61298	323p	1109	60897
280a	415	60727	316e	1199	61299	324a	1105	60918
280a	3367	29/3/34/77	316f	1200	61300	324b	798	60919
281a	424	60738	316g	1201	61301	324c ?	1092	60923
281a	1229	62705	316h	1202	61302	324d	1095	60924
282a	417	60733	316i	1203	61303	324e	1094	60925
282a	1580 (3)	62735	316j	1204	61304	324f	1093	60926
283	1256	62340	316k	1205	61305	324g	806	60898
283	1256	62618	316l	1206	61306	324h	794	60905
283a	427	60754	316m	1207	61307	324i	799	60906
283b	418	60747	316n	1208	61308	324j	1108	60908
283c	419	60748	316o	1209	61309	324k	802	60909
284	480	61334	316p	1210	61310	324l	789	60910
285	460	61343	317	1049	61475	324m	807	60899
286	461	61345	317a	956-7	60692	324n	790	60911
287	3102	61340	317a1	958-9	60693	324o	808	60912
288	—	62702	317a2	960	60694	324p	809	60917
288	1064	60703	317b	—	62723a	324q ?	1112	60900
289a	993	60715	317b	961-2	60695	324r ?	1110	60901
289b	410	60714	317b 1	963-4	60696	324s	792	60931
289c	996	60731	317b 2	—	30/3/34/51	324t	791	60932
290a	422	60734	318	1632	61483	325	1311	61485
291a	432	60739	318a	462	60830	325a	464	60838
291a	1230	62703	318b	463	60826	325b	1088	60839
291a	3363	29/3/34/85	318c	907	60837	325c	476	60764
292a	433	60742	319a	801	60944	325d ?	477	60765
292a	3361	29/3/34/86	319b	800	60945	325e ?	478	60779
293a	434	60746	319c	1102	60895	325f	1154	61122
293a	3357	29/3/34/87	319d	793	60929	326	1312	61486
294a	430	60740	319e	1101	60928	326a	465	60835
295a	425	60724	319f	1106	60854	326b	479	60808
296	409	60711	319g	1098	60865	326c	810	61051
296a	408	60716	319h	796	60939	326d	1171	61052
296n	360	62360	319i	1104	60940	326e	811	61053
297a	426	60737	319j	1183	60941	326f	1160	61055

Carter	Ausstellung	JE	Carter	Ausstellung	JE	Carter	Ausstellung	JE
326g ?	1159	61056	328n ?	777	60968	von 355	—	S-4491
326h	1150	61057	329	1634	61488	356	1580 (15)	62715
326i	1161	61058	329a	769	60992	357	728	61389
326j	813	61059	329b	1125	60993	359	618	62146
326k	1156	61060	329c	771	60994	360	748	62113
326l ?	1157	61061	329d	1124	60995	362	1306	62324
326m	1158	61062	329e	1128	61010	364	1580 (13)	62716
326n	814	61063	329f	770	61011	365	1580 (9)	62721
326o	1146	61064	329g	766	61012	367	1639	61451
326p	1155	61090	329h	1132	61024	367b	1261	62692
326q	1182	61099	329i	772	61025	367c	731	61385
326r ?	1176	61100	329j	1129	61026	367d	567	62256
326s	816	61101	329k ?	1130	61027	367f	569	62675
326t ?	1175	61102	329l	781	61045	367g	896	62467
326u	817	61103	330	—	62740	367g	897	62550
326v ?	1148	61123	330	1640	61453	367g	898	62453
326w	1147	61124	330a	1086	60820	367g	1085 (102)	62497
326x	1174	61144	330b	475	60821	367g	1085 (103)	62498
326y	1138	61125	330c	906	60823	367g	1085 (104)	62468
327a	1178	61153	330d	1087	60822	367g	1085 (105)	62455
327b	822	61154	330e	473	60824a	367g	1085	
327c	1180	61155	330f	474	60824b		(106–11)	62544–9
327d ?	1181	61156	330g	472	60834	367g	1085 (112)	62551
327e ?	1177	61157	330h	466	60833	367g	1085	
327f	1179	61158	330i	467	60827		(113–4)	62572–3
327g	821	61159	330j	468	60828	367g	1085	
327h	1167	61105	330k	469	60836		(98–101)	62558–61
327i	812	61106	330l	780	61049	367i	1666	62625
327j	1169	61107	330m	779	61050	367j	642	62626
327k	1168	61111	330n	1135	61046	367k	977	61491
327l	824	61147	330o ?	782	61048	367l	999	62087
327m	819	61148	331	454	60721	367m	1000	62089
327n	1142	61149	331	454	61263a–e	367n	577	62093
327o	827	61126	331a	449	60720	367o	632	61609b
327p	1140	61127	332	3100	61332	367q	1006	
327q	1164	61150	332	3231	61994a	(1–15)	61809–23	
327r	1165	61151	332	3239–40	61994b–c	367r	658–61	61793–806
327s	818	61145	332	3241	61994e	367r	1007	
327t	1166	61146	333	—	61992e		(1–4)	61824–7
327u	1145	61128	333	1333	61997	367r	1007	
327v	1137	61129	333	1701	61992a		(5–14)	61793–806
327w	820	61130	333	1701	61992b–c	368	1580 (15)	62715
327x	1144	61131	333	1701	61992f	369	1580 (10)	62720
327y	1141	61132	334	1326	61331	370a	741	61639
327z	1143	61133	335	441	61502	370b	1030	61640
327aa	826	61134	336	459	61328	370c	1027	61641
327bb	1151	61135	337a	1469	61034	370e	1031	61642
327cc	1139	61136	337a	1470	61035	370f	1029	61643
327dd	815	61137	337a	1536	61037	370g	1032	61644
327ee	1153	61112	337a	1548	61036	370j	952	61771
327ff	823	61113	337a	1551	61038	370k	612	61605
327gg	1170	61114	337b	1488	61013	370l	613	61606
327hh ?	1163	61138	337b	1532	61006	370m	614	61596
327ii ?	1149	61115	337c	1464	60999	370n	1058	61602
327jj	1173	61116	337c	1465	61000	370o	1062	61597
327kk	1152	61117	337c	1468	61001	370p	1063	61598
327ll	1162	61118	338	704	61392	370q	1060	61599
327mm ?	825	61120	339	939	62134	370s	1059	61600
327nn	1172	61121	340	584	62145	370t	619	61603
328	1633	61487	341	1580 (9)	62721	370t	1061	61601
328a	1123	60985	342	1580 (11)	62719	370u	622	61604
328b	776	60962	343	992	62171	370v	633	61610
328c	1114	60956	344	547	62129	370w	624	61592
328d	775	60955	345	540	62058a–o	370x	625	61593
328e ?	1119	60965	347	1580 (9)	62721	370z	1583	61594
328f ?	1121	60949	348	1580 (15)	62715	370aa	623	61608
328g ?	778	60954	348	1580 (7)	62717	370bb	628	61595
328h	1117	60979	349	563	62032	370cc	629	61607
328i	1116	60980	350	1066	61579	370dd	630	61609a
328j	1122	60981	351	983	62030	370ee	631	61620
328k	1118	60988	353	987	62156	370ff	3114	61528
328l	1120	60970	354	575	62056	370gg	3140	61521
328m	1115	60982	355	1580 (17)	62712	370hh	3116	61534

Carter	Ausstellung	JE	Carter	Ausstellung	JE	Carter	Ausstellung	JE
370ii	1600	61530	389	829	62073	441	1580 (11)	62719
370jj	3111	61529	390	840-3	61548	442b	1011	62049
370kk	1598	61538	392	1682	62305	442c	580	62082
370ll	930	61543	393	541	62061	442c	1012	62053
370mm	940	61546	394	554	62190	446	1580 (9)	62721
370nn	848-50	61550	396	1580 (9)	62721	448	990	62176
370nn	851	61551	397	565	62685	449	923	62133
370oo	—	61565	399a	572	62247	450	1580 (9)	62721
370oo	852-3	61559	399b	697	61867	451	1580 (13)	62716
370pp	—	61566	400	1580 (15)	62715	452	1580 (9)	62721
370qq	—	61564	400	1580 (7)	62717	453	1338	61464
370rr	855-8	61555	401	1580 (17)	62712	453b	3387	30/3/34/19
370ss	844-7	61549	von 401	—	S-4491	453b	3388	30/3/34/20
370tt	864-7	61554	402	568	61292	453b	3389	30/3/34/21
370uu	872-6	61556	403	738	61446	453b	3390	30/3/34/22
370vv	868-71	61567	403a	531	62022	453b	3391	30/3/34/23
370vv	877-84	61557	403b	532	62021	453b	3392	30/3/34/24
370ww	861-3	61568	403c	533	62020	453b	3393	30/3/34/25
370ww	3171 (8)	61553	403d	534	62023	453b	3394	30/3/34/26
370xx	3172 (1,2)	61553	404	617	62164	453b	3396	30/3/34/28
370zz	1638	61558	405	585	62172	453b	3397	30/3/34/29
371	1580 (13)	62716	406	986	62276	453b	3398	30/3/34/30
372	1580 (9)	62721	407	583	62135	453b	3399	30/3/34/31
373	3387	30/3/34/19	408	621	62136	453b	3400	30/3/34/32
373	3388	30/3/34/20	409	—	62330	453b	3401	30/3/34/33
373	3389	30/3/34/21	410n	574	62131	453b	3402	30/3/34/34
373	3390	30/3/34/22	411	—	62309	453b	3403	30/3/34/35
373	3391	30/3/34/23	412	549	62043	453b	3404	30/3/34/36
373	3392	30/3/34/24	413	1683	62306	453b	3405	30/3/34/37
373	3393	30/3/34/25	414	1013	62054	453b	3406	30/3/34/38
373	3394	30/3/34/26	415	539	62003	453b	3407	30/3/34/39
373	3396	30/3/34/28	416	1580 (9)	62721	453b	3408	30/3/34/40
373	3397	30/3/34/29	417	578	62130	453b	3409	30/3/34/41
373	3398	30/3/34/30	418a	1396	60860	453b	3410	30/3/34/42
373	3399	30/3/34/31	418a	1397	60857	453b	3411	30/3/34/43
373	3400	30/3/34/32	418a	1398	60859	453b	3412	30/3/34/44
373	3401	30/3/34/33	418b	1404	60874	453b	—	62689
373	3402	30/3/34/34	418b ?	1405	60873	oder 373	—	62690
373	3403	30/3/34/35	418c	1399	60902	453b	—	62638
373	3404	30/3/34/36	418d	1419	60935	oder 373	—	62634
373	3405	30/3/34/37	418d	1420	60933	456a	—	62638
373	3406	30/3/34/38	418d	1421	60936	457	756	62034
373	3407	30/3/34/39	418d	1422	60904	458	1089	60829
373	3408	30/3/34/40	418e ?	1400	60850	459a	1555	60963
373	3409	30/3/34/41	418e	1401	60849	459a ?	1556	60964
373	3410	30/3/34/42	418e	1402	60848	459a	1576	60967
373	3411	30/3/34/43	418e	1403	60847	459b	1429	60986
373	3412	30/3/34/44	418f ?	1406	60866	459c	1578	60953
373 oder	—	62689	418f ?	1417	60868	459d	1553	60984
453b	—	62689	418f ?	1418	60867	459d	1575	60983
373 oder	—	62690	418g ?	1369	60927	459e ?	1546	60951
453b	—	62690	418g ?	1395	60903	459e ?	1558	60950
374	579	62166	418g ?	1426	60891	459e	1559	60952
375	3086	61360	419	1580 (9)	62721	459e	1560	60961
377	1065	62015	420	627	62121	459e	1577	60959
378	982	62045	421	1009	62173	459f ?	1463	60978
379a	753	61577	422	729	61384	459f	1528	60977
379b	754	61576	423	582	62170	459f	1534	60973
380a	1457	61047	426	1580 (10)	62720	459f	1570	60971
380b	1563	60958	427	1580 (9)	62721	459f	1571	60975
380c	1562	60957	429	1580 (10)	62720	459f	1573	60976
380d	1559	60966	430	840-843	61548	459f	1574	60972
380d	1561	60960	431	925	62325	459g	1557	60948
380e	1572	60987	434	1681	62304	460	3085	61355
380f	1552	60969	435	548	62127	461a	647	62234
380f	1568	60989	436b	1259	62683	461b	648	62235
380g	1569	60974	437	3099	61337	461c	1021	62231
381	1580 (9)	62721	438-465	1581	60704	461d	649	62236
384	1580 (9)	62721	438-465	1581	60705	461e	1022	62232
385	552	62132	438-465	1581	60706	461f	1018	62220
386	739	61447	439	1580 (16)	62713	461g	1025	62221
387	1350	62074	440a	705	61393	461h	650	62222
389	735	62004	440a-c	1580 (9)	62721	461i	1016	62223

Carter	Ausstellung	JE	Carter	Ausstellung	JE	Carter	Ausstellung	JE
461j	651	62224	496e	1438	61139	519c	1567	61096
461k	1026	62225	496e?	1455	61119	519d	1375	61104
461l	1017	62226	496e	1456	61142	519e?	1430	61162
461m	1024	62227	496e	1458	61143	519e	1431	61163
461n	1020	62228	498	—	62328	519e	1432	61164
461o	1019	62229	498	—	62329	519e	1462	61160
461p	1023	62233	500	1677	62300	519f	1439	61161
461q	652	62230	502	924	62326	519f	1453	61165
461r	653	62237	503	1677	62299	519f	1454	61166
461s	654	62233	503?	3228	27/3/34/03	519f	1460	61167
461t	655	62239	504	1580 (9)	62721	519f	1461	61168
461u	1015	62245	506	1580 (11)	62719	520	543	62123
461v	656	62242	508	1687	62313	521	1580 (9)	62721
461w	657	62241	509	—	—	522	1342	61480
461x	646	62243	oder 570	—	62323	522	1342	62109b
461y	1014	62246	(509)	1686	62312	523	1678	62301
462	3095	61352	511	1582	62044	524	620	62149
463	3087	61361	511	1684	62307	525	1286	61935
464	3104	61349	512a	1379	60783	526	1580 (6)	62723
466	530	62014	512a	1480	60784	527a	1580 (10)	62720
467	550	62038	512a	1507	60788	527b	1580 (15)	62715
468a	—	61670	512a?	1508	60787	528	1580 (10)	62720
468b	—	61671	512a?	1509	60786	530	1580 (10)	62720
468c	1605	61750	512a	1513	60785	531	1580 (16)	62713
468d	1607	61752	512a?	1543	60782	532	1580 (9)	62721
468e	1055	61747	512b	1393	60793	533	1580 (9)	62721
468e	1606	61751	512b?	1506	60809	534	1580 (9)	62721
468g	1054	61746	512c	1376	60806	538	1580 (9)	62721
468h	1052	61744	512c	1378	60807	539	—	62311
468i	1603	61748	512c	1473	60810	540	1189	61477
468j	1053	61745	512c	1510	60800	541	—	62310
468k	1610	61709	512d	1391	60768	542	1580 (10)	62720
468l	1609	61710	512d	1448	60771	544	1580 (10)	62720
468m	1608	61712	512d	1450	60769	545	733	61582
468n	1056	61711	512e?	1385	60816	546	1641	61450
468o	1051	61714	512e	1441	60811	547	751	61457
469	576	62192	512e	1449	60817	547b	1307	61939
470	1580 (10)	62720	512e	1451	60812	547c	1308	62381
471	1580 (9)	62721	513	3097	61333	547d	1225	62026
472	1580 (9)	62721	514a?	1467	61033	548a	1226	62027
473	1580 (16)	62713	514a	1533	61028	549	—	62322
474	1580 (9)	62721	514a?	1547	61031	550	1641	61450
475	546	62128	514a?	1550	61032	551	1189	61477
479	991	62175	514b	1489	61016	553a-b	1580 (9)	62721
480	615	62142	514b	1490	61017	554	1580 (9)	62721
481	3088	61362	514b	1491	61018	555	1580 (9)	62721
482	616	62174	514c	1529	60997	556	3090	61359
483	626	62143	514c	1530	60998	559a-b	1580 (9)	62721
484	1580 (15)	62715	514d	1471	60996	560	1685	62308
485	988	62141	516	—	62320	561	573	61264
486	1680	62303	517a	1483	60774	562	1580 (11)	62719
487	744	61482	517a	1512	60775	563	—	62319
488a	1068	61581	517b	1380	60781	565	1580 (9)	62721
488b	1070	61578	517b	1394	60780	566	1067	61583
489	1327	62317	517b	1515	60778	567	1580 (10)	62720
490	1679	62302	517c	1387	60799	568	1328	62318
491	3096	61354	517d?	1381	60814	569	1580 (9)	62721
491	3099	61337	517d?	1475	60777	570	—	62323
492	1069	61580	517e?	1368	60886	oder 509	—	62323
493	1036	61479	517e	1423	60934	572	3097	61333
494	1036	61479	517f?	1354	60879	573a	1580 (9)	62721
496a	1347	60840	517f?	1363	60893	573b	1580 (10)	62720
496b	1383	60760	517g	1367	60938	573c	1580 (12)	62714
496b	1384	60759	517h	1351	60920	573d-e	1580 (9)	62721
496b	1538	60758	517h	1358	60921	573f	1580 (6)	62723
496c?	1540	60766	517h	1373	60913	574	750	61495
496c	1542	60767	517h	1424	60922	575	899	61478
496d	1459	61110	518b	1580 (13)	62716	577	536	61759
496d	1531	61109	519a	1566	61054	578	635	62120
496d	1549	61108	519b	1564	61095	579	544	62124
496e	1433	61140	519c	?	87852	580	540	62058a-o
496e?	1434	61152	519c	1260	61097	581	3089	61351
496e	1437	61141	519c	1565	61098	582a	537	61588

Carter	Ausstellung	JE	Carter	Ausstellung	JE	Carter	Ausstellung	JE
582b	737	61652	597	3101	61342	602g (?)	1246 (29)	61237
582c	662	61654	598	3100	61332	602g (?)	1246 (3-4)	61242
582d	663	61655	599	1585	62005	602g (?)	1246 (30)	61200
582e	664	61656	600	1586	62006	602g (?)	1246 (30)	61230
582f	665	61657	600a-d	1187	62018	602g (?)	1246 (30)	61238
582g	1653	61662	601	908	60831	602g (?)	1246 (31)	61223
582h	1654	61663	602a	1382	60761	602g (?)	1246 (31)	61239
582i	652	61661	602a ?	1539	60763	602g (?)	1246 (32)	61229
583	587	62168	602a ?	1541	60762	602g (?)	1246 (32)	61240
584	545	62122	602b	1527	60846	602g (?)	1246 (33)	61228
585	752	61456	602c	1525	60842	602g (?)	1246	
585a	598	62407	602d	1493	60845		(33-4)	61252
585b	599	62412	602d	1494	60844	602g (?)	1246 (34)	61227
585c	600	62408	602e	1495	60843	602g (?)	1246 (35)	61226
585c	602	62410	602e	1526	60841	602g (?)	1246	
585d	601	62413	602f	?	87853		(35-6)	61253
585f	603	62409	602f?	?	87854	602g (?)	1246 (36)	61225
585g	604	62411	602f	1407	61080	602g (?)	1246 (36)	61231
585h	605	62414	602f	1408	61081	602g (?)	1246 (37)	61224
585i	593	62422	602f	1409	61088	602g (?)	1246 (37)	61254
585j	594	62424	602f	1410	61082	602g (?)	1246	
585k	595	62421	602f	1411	61083		(38-9)	61255
585l	596	62423	602f	1412	61089	602g (?)	1246 (40)	61256
585m	597	62425	602f	1413	61084	602g (?)	1246 (41)	61191
585n	608	62403	602f	1414	61085	602g (?)	1246	
585o	609	62399	602f	1415	61086		(41-4)	61257
585p	—	62426	602f	1416	61087	602g (?)	1246 (42)	61192
585p	—	62427	602f	1496	61091	602g (?)	1246 (43)	61193
585p	1343	27/3/34/38	602f	1497	61092	602g (?)	1246 (44)	61194
585q	606	62406	602f	1498	61093	602g (?)	1246 (45)	61195
585r	542	62060	602f	1499	61066	602g (?)	1246 (46)	61196
585u	708a	61870	602f	1500	61067	602g (?)	1246 (47)	61197
585u	708b	61871	602f	1501	61068	602g (?)	1246 (48)	61198
585x	3319	29/3/34/45a-b	602f	1502	61069	602g (?)	1246 (49)	61199
585x	3380	29/3/34/95	602f	1503	61070	602g (?)	1246	
585x	3381	30/3/34/46	602f	1504	61071		(5-6)	61243
585y	1084	61572	602f	1505	61072	602g (?)	1246 (50)	61203
585y	1084	61573	602f	1516	61094	602g (?)	1246 (51)	61204
585aa	560	61322	602f	1517	61073	602g (?)	1246 (52)	61205
585bb	997	62092	602f	1518	61065	602g (?)	1246 (53)	61206
585bb	998	62091	602f	1519	61074	602g (?)	1246 (54)	61207
585cc	942	61571	602f	1520	61075	602g (?)	1246 (55)	61208
585ff5	242	62428	602f	1521	61076	602g (?)	1246 (56)	61210
586	1187	62018	602f	1522	61077	602g (?)	1246 (57)	61211
587	1639	61451	602f	1523	61078	602g (?)	1246 (58)	61212
587	1674	62628	602f?	1524	61079	602g (?)	1246 (59)	61213
587b	695	61831	602g (?)	1246		602g (?)	1246 (60)	61214
587d	700	61792		(1-15)	61250	602g (?)	1246 (61)	61215
588	564	62144	602g (?)	1246		602g (?)	1246 (62)	61216
589	703	61383		(1-2)	61241	602g (?)	1246 (63)	61217
589	1580 (8)	62718	602g (?)	1246		602g (?)	1246 (64)	61218
589a	730	61395		(10-1)	61245	602g (?)	1246 (65)	61219
591	1580 (8)	62718	602g (?)	1246		602g (?)	1246 (66)	61220
592	1010	62050		(12-3)	61246	602g (?)	1246 (67)	61221
593	566	62059	602g (?)	1246		602g (?)	1246	
596a	734	62002		(12-21)	61233		(7-9)	61244
596d	1622	61679	602g (?)	1246		602g (?)	1246	
596f	1623	61698	(14-5)	61247			(9-11)	61232
596g	1050	61681	602g (?)	1246		602g (?)	1247 (1)	61171
596i	980	61739		(16-7)	61251	602g (?)	1247 (2)	61172
596k	1596	61532	602g (?)	1246 (18)	61249	602g (?)	1247 (3)	61173
596l	1601	61536	602g (?)	1246		602g (?)	1247 (4)	61174
596m	1597	61531		(19-20)	61248	602g (?)	1247 (5)	61175
596n	3109	61540	602g (?)	1246		602g (?)	1247 (6)	61176
596o	3108	61541		(19-32)	61250	602g (?)	1247 (7)	61177
596p	929	61542	602g (?)	1246		602g (?)	1247 (8)	61178
596q	1599	61518		(22-5)	61234	602g (?)	1247 (9)	61179
596r	3112	61539	602g (?)	1246 (26)	61222	602g (?)	1247 (10)	61180
596s	3115	61535	602g (?)	1246 (27)	61209	602g (?)	1247 (11)	61181
596s ?	736	61740	602g (?)	1246 (27)	61235	602g (?)	1247 (12)	61182
596t	928	61516	602g (?)	1246 (28)	61202	602g (?)	1247 (21)	61183
596v	854	61569	602g (?)	1246 (28)	61236	602g (?)	1247 (22)	61184
596v	859-860	61552	602g (?)	1246 (29)	61201	602g (?)	1247 (23)	61185

Carter	Ausstellung	JE	Carter	Ausstellung	JE	Carter	Ausstellung	JE
602g (?)	1247 (24)	61186	611a?	1357	60882	620 (33)	570	62219
602g (?)	1247 (25)	61187	611a?	1360	60914	620 (34)	571	62268
602g (?)	1247 (38)	61188	611a?	1361	60915	620 (35)	672	62195
602g (?)	1247 (39)	61189	611a?	1362	60916	620 (36)	673	62196
602g (?)	1247 (40)	61190	611b	1355	60880	620 (37)	553	62191
602g (?)	3000	61243	611b?	1359	60883	620 (38)	588	62420
602g (?)	3001	61241	611b	1365	60885	620 (39)	589	62418
602g (?)	3002	61242	611b	1374	60889	620 (40)	590	62417
602g (?)	3003	61245	611b?	1425	60890	620 (42)	592	62416
602g (?)	3004	61244	611b	1427	60892	620 (43)	607	62405
602g (?)	3005	61246	611b?	1352	60877	620 (44)	581	62083
602g (?)	3006	61247	611c	1353	60878	620 (44)	591	62415
602g (?)	3008	61250	611c	1356	60881	620 (44)	610	62402
602g (?)	3020	61230	611c?	1364	60884	620 (45)	611	62404
602g (?)	3024	61234	611c?	1366	60937	620 (46)	638	62397
602g (?)	3025	61231	611c?	1370	60887	620 (47)	721	62375
602g (?)	3027	61237	611c	1371	60888	620 (48)	722	62376
602g (?)	3029	61252	611c	1372	60894	620 (49)	723	62377
602g (?)	3032	61254	611c	1428	60876	620 (50)	—	61988
602g (?)	3033	61255	612	3093	61353	620 (52)	538	61589
602g (?)	3035	61256	613	1301	62055	620 (53)	676	61282
602g (?)	3036	61257	614a	1288	62279	620 (54)	678	61291
602g (?)	3038	61258	614b	1289	62280	620 (55)	682a	61311
602g (?)	3039	61259	614c	1290	62281	620 (55)	682b	61312
602g (?)	3040	61260	614e	1291	62282	620 (55)	682c	61313
602g (?)	3041	61261	614f	1292	62283	620 (55)	682d	61314
602g (?)	3042	61262	614g	1293	62284	620 (56)	—	62557
603	989	62177	614h	1294	62285	620 (56)	681	61287
604	1008	62179	614i	1295	62286	620 (56)	885	62543
605a	1436	61043	614k	1296	62278	620 (56)	886	62465
605b	1435	61044	615	751	61457	620 (56)	887	62552
605c	1440	61022	616	706	61394	620 (56)	888	62466
605c	1452	61020	616	1580 (6)	62723	620 (56)	889–890	62570–1
605c	1472	61021	617	3092	61357	620 (56)	892	62539
605d	1544	61030	619a	1655	61664	620 (56)	893–894	62574–5
605d	1545	61029	619b	666	61658	620 (56)	895	62469
605e	1492	61014	619c	667	61659	620 (56)	1085	
605e	1535	61015	619d	668	61660		(1–8)	62562–9
605f	1484	61040	620	1267 (11)	62742	620 (56)	1085	
605g	1466	61005	620	1267 (12)	62753		(49–75)	62470–96
605g?	1485	61002	620 (1)	1300	62072	620 (56)	1085	
605g	1486	61003	620 (2)	1299	62189		(76–84)	62456–64
605g?	1487	61004	620 (4)	635	61613	620 (56)	1085	
607b	1033	61645	620 (5)	636	61612		(85–7)	62540–2
607c	742	61649	620 (6)	637	61614	620 (56)	1085 (88)	62454
607d	740	61647	620 (7)	1057	61615b	620 (56)	1085 (89)	62555
607e	1028	61648	620 (8)	639	61616	620 (56)	1085	
607h	743	61650	620 (9)	640	61622		(9–48)	62499–62538
607i	1034	61651	620 (10)	1038	61621	620 (56)	1085 (90)	62578
608a	1340	60804	620 (11)	641	61618	620 (56)	1085 (91)	62579
608a	1389	60803	620 (12)	644	62710	620 (56)	1085 (92)	62554
608a	1392	60801	620 (12)	645	62711	620 (56)	1085 (93)	62556
608a	1482	60802	620 (12)	1584	61619	620 (56)	1085	
608a	1514	60805	620 (13)	726	62064		(94–5)	62576–7
608b	1477	60796	620 (14)	685	61786	620 (56)	1085 (96)	62553
608b	1478	60795	620 (15)	686	61787	620 (56)	1085 (97)	62580
608c	1386	60794	620 (16)	687	61788	620 (57)	677	61290
608c	1388	60797	620 (17)	688	61789	620 (58)	680	61279
608c	1443	60818	620 (18)	692	61828	620 (59)	679	61280
608c	1446	60792	620 (19)	693	61829	620 (60?)	551	61590
608c	1474	60790	620 (20)	694	61830	620 (61)	555	61591
608c	1476	60819	620 (21)	689	61780	620 (62)	674	61270
608c	1479	60798	620 (22)	690	61781	620 (63)	675	61271
608c?	1481	60791	620 (23)	691	61782	620 (65)	1005	62096
608c	1511	60789	620 (24)	696	61791	620 (67)	710	61866
608d	1445	60815	620 (25)	701	61832	620 (68)	711	61288
608d	1447	60813	620 (26)	702	61784	620 (69)	712	61960
608d	1537	60776	620 (27)	699	61868b	620 (70)	713a	61956
608e	1377	60770	620 (28)	698	61868a	620 (70)	713b	61957
608e	1442	60773	620 (29)	558	62254	620 (70)	713c	61958
608e	1444	60772	620 (30)	559	62255	620 (70)	713d	61959
609	3094	61356	620 (31)	561	62240	620 (71)	714	61862
610	3091	61358	620 (32)	562	62244	620 (72)	715	61857

Carter	Ausstellung	JE	Carter	Ausstellung	JE	Carter	Ausstellung	JE
620 (73)	716	61858	620 (97)	3260	62584	620 (119)	3393	30/3/34/25
620 (74)	724	62379	620 (98)	3263	62587	620 (119)	3394	30/3/34/26
620 (75)	725	62378	620 (99)	3262	62586	620 (119)	3396	30/3/34/28
620 (76)	717	61954	620 (100)	684	62108	620 (119)	3397	30/3/34/29
620 (77)	718	61953	620 (101)	720	62110	620 (119)	3398	30/3/34/30
620 (78)	719	61955	620 (102)	3261	62585	620 (119)	3399	30/3/34/31
620 (79)	1267 (3)	62098	620 (103)	3259	62583	620 (119)	3400	30/3/34/32
620 (80)	1267 (1)	62099	620 (104)	3257	62581	620 (119)	3401	30/3/34/33
620 (81)	1267 (4)	62102	620 (105)	727	62109 _a	620 (119)	3402	30/3/34/34
620 (82)	1267 (6)	62101	620 (106)	669	62104	620 (119)	3403	30/3/34/35
620 (83)	1267 (5)	62100	620 (107)	3258	62582	620 (119)	3404	30/3/34/36
620 (85)	1267 (2)	62097	620 (108)	670	62105	620 (119)	3405	30/3/34/37
620 (86)	1267 (7)	62103	620 (109)	671	62106	620 (119)	3406	30/3/34/38
620 (88)	1267 (10)	62744	620 (110)	566	62059	620 (119)	3407	30/3/34/39
620 (89)	1001	62088	620 (113)	1090	60832	620 (119)	3408	30/3/34/40
620 (90)	1002	62086	620 (119)	—	62689	620 (119)	3409	30/3/34/41
620 (91)	1003	62090	620 (119)	—	62690	620 (119)	3410	30/3/34/42
620 (92)	1004	62085	620 (119)	3387	30/3/34/19	620 (119)	3411	30/3/34/43
620 (93)	586	62084	620 (119)	3388	30/3/34/20	620 (119)	3412	30/3/34/44
620 (94)	707	61973	620 (119)	3389	30/3/34/21	620 (121)	1242	61499
620 (94)	978	61265	620 (119)	3390	30/3/34/22	620 (122)	1248	62150
620 (95)	643	61492	620 (119)	3391	30/3/34/23	620 (123)	1310	61940
620 (96)	683	62107	620 (119)	3392	30/3/34/24			

KONKORDANZ NACH AUSSTELLUNGSNUMMERN

Ausstellung	JE	Carter	Ausstellung	JE	Carter	Ausstellung	JE	Carter
—	S-4466	von 21s?	—	61722	135w	—	30/3/34/51	100g
—	S-4470	von 32?	—	61723	50qq	—	30/3/34/51	101q
—	S-4471	von 193?	—	61725	135v	—	30/3/34/51	317b2
—	S-4474	?	—	61757	212	—	61705	135o
—	S-4477	von 46kk?	—	61758	215	—	62723a	115
—	S-4478	von 266g	—	61770	135s	?	S-4455	?
—	S-4479	von 266g	—	61982	44a	?	S-4456	von 21j?
—	S-4480	von 266g	—	61983	44a	?	S-4457-63	?
—	S-4481	von 266g	—	61984	44a	?	87847	?
—	S-4482	von 266g	—	61985	50tt	?	87848	?
—	S-4483	von 35	—	61986	50tt	?	87849	?
—	S-4486	von den Schreinen	—	61987	58ss	?	87850	?
—	S-4487	von 207?	—	61988	620 (50)	?	87851	?
—	S-4488	?	—	61992e	333	?	87852	519c
—	S-4490	von Wagen 'C'?	—	62309	411	?	87853	602f
—	S-4491	von 401	—	62310	541	?	87854	602f?
—	S-4491	von 355	—	62311	539	?	87855a-b	?
—	S-4492	von 158o (10)	—	62319	563	?	87856	?
—	S-4493	von 158o (9)	—	62320	516	?	87857	?
—	S-4494	—	—	62321	—	1	62028	91
—	S-4495	von 158o (12)	—	62322	549	2	62046	90
—	S-4496	von 158o (6)	—	62323	509 oder 570	3	62029	87
—	S-4497	von 158o (15)	—	62323	570 oder 509	4	62048	88
—	S-4498	von 158o (11)	—	62327	105	6	62116	57
—	S-4499	?	—	62328	498	7	62118	60
—	S-4500	von 158o (19)	—	62329	498	8	62117	61
—	61561	48y	—	62330	409	9	62115	58
—	61562	46a (3)	—	62345	—	10	62157	59
—	61563	46a (2)	—	62426	585p	11	62125	24
—	61564	370qq	—	62427	585p	12	61466	40
—	61565	370oo	—	62557	620 (56)	13	61476	44
—	61566	370pp	—	62638	456a	14	61481	108
—	61627	50ll	—	62657	50j	15	62035	83
—	61628	50v	—	62658	101u	16	60722	116
—	61629	50mm	—	62659	50p	17	60825	110
—	61630	50aa	—	62660	50o	18	60751	37
—	61637	48m	—	62661	50h	19	60750	37a
—	61670	468a	—	62684	21h-i	20	62016	47
—	61671	468b	—	62689	620 (119)	21	61468	101
—	61675	(13?)5vv	—	62689	373 oder 453b	22	62033	39
—	61676	48n	—	62689	453b oder 373	23	62052	92
—	61677	135y	—	62690	620 (119)	24	62041	81
—	61678	48o	—	62690	373 oder 453b	25	62039	74
—	61680	214b	—	62690	453b oder 373	26	62040	84
—	61683	48r (?)	—	62694	252	27	62356	41
—	61684	48t	—	62695	252a	28	62355	41
—	61685	48u	—	62696	254b	29	62354	41
—	61686	135u	—	62697	255b	30	62353	41
—	61687	135r	—	62699	256mmu	31	62010	75
—	61688	135b	—	62702	288	32	62009	76
—	61689	135j	—	62723a	317b	33	62147	27
—	61690	135m	—	62740	330	34	62126	45
—	61691	135f	—	62746	120	35	62158	16
—	61692	135c	—	62751	34	36	62167	127
—	61693	135a	—	62755	—	37	62138	128
—	61694	135k	—	62759	—	38	62165	124
—	61695	135g	—	62760	—	39	62169	125
—	61696	135e	—	62761	—	40	62248	54ccc
—	61697	135p	—	62762a	—	41	62264	54h
—	61704	214a	—	62762b	—	42	62204	54z
—	61706	135-?	—	30/3/34/51	21	43	62249	54w
—	61707	135l	—	30/3/34/51	21d oder e	44	62265	54rr*
—	61708	135n	—	30/3/34/51	25b	45	62266	54rr**
—	61720	135t	—	30/3/34/51	79f	46	62259	54qq*
—	61721	135i	—	30/3/34/51	79h	47	62258	54qq**

Ausstellung	JE	Carter	Ausstellung	JE	Carter	Ausstellung	JE	Carter
48	62260	54qq***	123	61730	98	184	62111	173
49	62261	54qq****	124	61996	135cc	185	62114	210
50	62257	54n	125	62008	50gg	186	62007	175a-b
51	62262	54t	126	61638	50pp	187	62001	242
52	62263	54u	127	61544	48i (1)	188	62000	245
53	62202	54bbb	128	61525	48j (1)	189	61753	227c
54	61320	50dd	129	61754	50nn	190	61755	227b
55	61315	50dd**	130	61713	48e	191	61756	227a
56	61316	50ee*	131	61715	95	192	61785	25o
57	61317	50ee**	132	61995	50ss	193	61489	193
58	61318	50ff**	133	61673	50jj	194	60755	176
59	61319	50ff**	134	61653	50xx	195	61665	235a
60	62252	31	135	61741	135aa	196	61666	235b
61	62251	31a	136	62198	40a	197	61674	224
62	62253	63	137	62201	32l	198	62210	54ii
63	62250	25	138	62199	32j	199	62205	54aa
64	60719	54ee	139	62200	32k	200	62206	54bb
65	61974	44o	140	61617	54e	201	62207	54cc
67	62430	44i	141	61615a	54d	202	62217	54x
68	62437	44c	142	62194	44s	203	62203	54oo
69	62429	44d	143	61325	54i	204	62215	54nn
70	62436	44h	144	62122	92e	205	62208	54dd
71	62346	54ddd 5	145	61170	106a	206	62212	54l
72	62445	44e	146	61321	46aa	207	62218	69
73	62451	44f	147	61281	54c	208	62213	54ll
74	60718	54ff	148	61289	147d	209	62214	54mm
75	61976	54q	149	61169	94b	210	62209	54g
76	61975	54ddd 4	150	61293	44v	211	62216	54pp
77	62450	44g	151	61294	44p	212	62211	54jj
78	62444	44j	152a	61266	32o	213	61742	213
79	61872	44l	152b	61267	32o	214	61743	227d
80	60717	54vv	152c	61268	32o	215	61726	227e
81	61874	44gg	152d	61269	32o	216	61667	204
82	61873	44k	153a	61272	32p	217	61623	233
84	61889	54yy	153b	61273	32p	218	61624	218
85	61952	108c	154a	61274	39q	219	60671	255
86	61762	44u	154b	61275	39q	220	60672	256a
87	62025	101o	154c	61276	39q	221	62012	137
88	62024	21c	154d	61277	39q	222	60670	254
89	61449	54ddd	154e	61278	39q	223	61496	240 bis
90	62352	54s	155	62351	44y	224	61903	256b
91	61465	14a	156	62350	46jj	225	61584	256dd
92	61498	54hh	157	62358	46r	226	61585	256k
93	61493	14b	158a	61850	138	227	61900	256ooo
94	61454	50	158b	61851	138	228	61892	256ppp
95	62017	80	158c	61849	138	229	61887	256qqq
96	60707	22	159	61833	46y	230	61891	256uuu
97	61990a	133-134	160	61790	99a	231	61901	256vvv
97	61990a	122	161	61962	54gg	232	61951	256rrr
98-9	61989a	120	162a	61963	25a*	233	61853	256 4q
98-9	61989a	131	162b	61964	25a**	234	62363	256zz
98-9	61989a	136	163	61965	54tt	235	62365	256rr
100-1	61990a	133-134	164a	61966	54ss	236	62367	256xx
100-1	61990a	122	164b	61967	54ss	237	62368	256xx
102-3	61989a	120	165	62401	92h	238	62364	256pp
102-3	61989a	131	166	62419	44ee	239	62366	256ww
102-3	61989a	136	167	62400	56a	240	62382	256n
104	61990a	133-134	168	61777	196	241	62442	256ff3
104	61990a	122	169	61776	199	242	62428	585ff5
105-6	61989b-c	zu 120	170	61775	200	243	62431	256ff1
107-8	61990b-c	122e	171	61774	201	244	62432	256ff4
109	61989g	120h	172	62359	181	245	62443	256bbb
110	61990g	122h	173	61381	42	246	62440	256vv 4
111	61989d	157	174	61391	97	247	62441	256vv 5
112	61990d	160	175	61732	50uu	248	62448	256ff2
113-4	61989e-f	152a-b	176	61733	48d	249	62446	256ccc
115-6	61990e-f	162c-d	177	61734	100a	250	62433	256vv 6
117	61586	—	178	61735	48b	251	62434	256vv 8
118	61587	—	179	61736	48c	252	62447	256vv 7
119	61537	48i (2)	180	61737	48a	253	62435	256vv 2
120	61517	48h	181	60708	29	254	62439	256vv 3
121	61526	48k (1)	182	62112	174	255	62438	256vv 1
122	61727	50oo	183	62119	211	256	62361	256qq

Ausstellung	JE	Carter	Ausstellung	JE	Carter	Ausstellung	JE	Carter
257	62362	256yy	327	60679	256lll**	396	61490	269
258	60674	256 4s	328	60680	256ll**	397	61462	267
259	60675	256 4p	329	60681	256ll***	398	62182	265a
260	62373	256aaa	330	60682	256ll****	399	62183	265b
261	62370	256ddd	331	60683	256ll*****	400	62184	265c
262	62369	256sss b	332	60752	38a	401	61380	271a
263	62372	256ooo	333	60753	38	402	62197	271f
264	62371	256sss	334	60677	256l	403	61763	269d
266	61902a	256a	335	60676	256ee	404	61760	269e
268	61937	256 4m	336	60673	256b	405	61761	269f
269	61848	256zzzz	337	62671	21z	406	61764	269h
270	60685	256j	338	62673	44ff	407	60709	275c
271	61860	256ggg	339	62674	46cc	408	60716	296a
272	61861	256 4b	340	62672	43i-j	409	60711	296
273	61865	256xxx	341	62680	21f-g	410	60714	289b
274	61863	256 4a	342	61893	267m*	411	60712	275b
275	61864	256yyy	343	61884	267d	412	60730	304a
276	61834	256fff	344	61885	267i u. l	413	60729	302a
277	62393	256ccc	345	61941	267i-j	414	60728	304b
278	62394	256w	345	61941	267q	415	60727	280a
279	62395	256jj 3	346	61961	269o	416	60726	301a
280	62396	256jj 4	347	61894	267i	417	60733	282a
281	62392	256jj 2	348	61886	267a	418	60747	283b
282	62389	256jj 1	349	61888	267p	419	60748	283c
283	62390	256u	350	61896	267g-h	420	60735	299a
284	62391	256v	351	61897	269k	421	60725	305a
285	62384	256uu	352	61895	267o	422	60734	290a
286	62385	256hh 2	353	61898	267e	423	60732	275a
287	62386	256hh 3	354	61890	267n	424	60738	281a
288	62387	256hh 1	355	61497	267c	425	60724	295a
289	62388	256www	356	61978	261l	426	60737	297a
290	62383	256hh	357	62374	269g	427	60754	283a
291	61852	256iii 3	358	61979	267b	428	60749	300a
292	61842	256 4r	359	62380	269m	429	60745	298a
293	61779	256hhh	360	62360	296n	430	60740	294a
294	61778	256kk	361	62449	271h	431	60741	303a
295	61977	256q	362	61938	267m 2	432	60739	291a
296	61869	256 4v	363	61968	269a 5	433	60742	292a
297	61839	256c	364	61969	269a 1	434	60746	293a
298	61838	256m	365	61970	269a 6	435	61374	194
299	61837	256iii	366	61902b	256b	436	61375	202
300	61836	256jjj	366	61971	269a 3	437-40	60687	266c-f
301	61856	256 4g	367	61972	269a 2	441	61502	335
302	61844	256 4i bis	368	61899	267k	442	60699	320b
303	61847	256 4h	369	61942	261p 2	443	60700	320d
304	61845	256 4l	370	61943	261p 3	444	60701	320e
305	61843	256 4i	371	61947	261n	445	60702	320c
306	61846	256 4j	372	61948	261m	446	61326	279a
307	61854	256 4k	372	61948	269a 4	447	61444	261
308	61855	256 4f	373	61949	261j	448	61999	272a
309	61841	256kkk	374	61944	261p 1	449	60720	331a
310	61840	256ttt	375	61945	261i	450	61330	321
311	61835	256d	376	61946	261o	451	61458	271
312	61917	269g	377	62349	269b	452	60688	266g
313	61913	256t	378	62348	271c-d	453	61461	268
314	61877	256z	379	62095	271g	454	61263a-e	331
315	61876	256mmm	380	62079	262	454	60721	331
316	61875	256nnn	381	62080	271e 2	455	60686	266
317	60684	256 4o	382	62081	271b	455	60686	266a
317	60684	256r	383	62094	271e 1	456	60686	266
317	60684	256s	384	61783	261k	456	60686	266a
318	61916	269f	385	61859	261f	457	60686	266
319	61915	256e	386	60946	261f	457	60686	266a
320	61918	269lll	387	60744	261f	458	60686	266
321	61914	256p	388	60743	261g	458	60686	266a
322	61911	256gg	389a	61807	261e	459	61328	336
323	61912	256h	389b	61808	261e	460	61343	285
324	61467	21	390	62357	263	461	61345	286
325	62148	130	391	60756	261g	462	60830	318a
326	62137	126	392	60757	267f	463	60826	318b
327	60678	256lll*	393	62186	261h	464	60838	325a
327	60678	256lll**	394	62185	261h	465	60835	326a
327	60679	256lll*	395	60736	264	466	60833	330h

Ausstellung	JE	Carter	Ausstellung	JE	Carter	Ausstellung	JE	Carter
467	60827	330i	540	62058a-o	345	623	61608	370aa
468	60828	330j	540	62058a-o	580	624	61592	370w
469	60836	330k	540	62058a-o	46x	625	61593	370x
470	60697	320	541	62061	393	626	62143	483
470	60698	320a	542	62060	585r	627	62121	420
471	61350	313	543	62123	520	628	61595	370bb
472	60834	330g	544	62124	579	629	61607	370cc
473	60824a	330e	545	62122	584	630	61609a	370dd
474	60824b	330f	546	62128	475	631	61620	370ee
475	60821	330b	547	62129	344	632	61609b	367o
476	60764	325c	548	62127	435	633	61610	370v
477	60765	325d?	549	62043	412	634	61611	307f
478	60779	325e?	550	62038	467	635	61613	620 (4)
479	60808	326b	551	61590	620 (60?)	635	62120	578
480	61334	284	552	62132	385	636	61612	620 (5)
481	61344	311	553	62191	620 (37)	637	61614	620 (6)
482	61347	308	554	62190	394	639	61616	620 (8)
483	61335	309	555	61591	620 (61)	640	61622	620 (9)
484	61339	310	558	62254	620 (29)	641	61618	620 (11)
485	61338	306	559	62255	620 (30)	643	61492	620 (95)
486	61336	314	560	61322	585aa	646	62243	461x
487	61373	182	561	62240	620 (31)	647	62234	461a
488	61372	183	562	62244	620 (32)	648	62235	461b
489	61371	184	563	62032	349	649	62236	461d
490	61370	185	564	62144	588	650	62222	461h
491	61369	186	565	62685	397	651	62224	461j
492	61368	187	566	62059	593	652	61661	582i
493	61367	188	566	62059	620 (110)	652	62230	461q
494	61366	189	567	62256	367d	653	62237	461r
495	61365	190	568	61292	402	654	62233	461s
496	61364	191	569	62675	367f	655	62239	461t
497	61363	192	570	62219	620 (33)	656	62242	461v
498	62051	67	571	62268	620 (34)	657	62241	461w
499	62274	203	572	62247	399a	658-	61793-	
500	62275	197	573	61264	561	61	806	367r
501	62270	177	574	62131	410n	662	61654	582c
502	62315	195	575	62056	354	663	61655	582d
503	62314	206	576	62192	469	664	61656	582e
504	62316	180	577	62093	367n	665	61657	582f
505	62019	64	578	62130	417	666	61658	619b
506	61481	108a	579	62166	374	667	61659	619c
507	62728	51	580	62082	442c	668	61660	619d
508	62730	142	581	62083	620 (44)	669	62104	620 (106)
509	62727	19a	582	62170	423	670	62105	620 (108)
510	61390	146	583	62135	407	671	62106	620 (109)
511	61390	32r	584	62145	340	672	62195	620 (35)
512	61382	119	585	62172	405	673	62196	620 (36)
513	61382	26	586	62084	620 (93)	674	62170	620 (62)
514	61728	229	587	62168	583	675	61271	620 (63)
515	62627	54k	588	62420	620 (38)	676	61282	620 (53)
516	61881	256aa**	589	62418	620 (39)	677	61290	620 (57)
517	61878	256i	590	62417	620 (40)	678	61291	620 (54)
518	61880	256aa*	591	62415	620 (44)	679	61280	620 (59)
519	61738	100l?	592	62416	620 (42)	680	61279	620 (58)
520	61545	48f	593	62422	585i	681	61287	620 (56)
521	62013	73	594	62424	585j	682a	61311	620 (55)
522	61523	48l	595	62421	585k	682b	61312	620 (55)
523	61524	48g	596	62423	585l	682c	61313	620 (55)
524	61533	48j (2)	597	62425	585m	682d	61314	620 (55)
525	61731	—	598	62407	585a	683	62107	620 (96)
526	61626	—	599	62412	585b	684	62108	620 (100)
527	61632	—	600	62408	585c	685	61786	620 (14)
528	61634	—	612	61605	370k	686	61787	620 (15)
529	61729	—	613	61606	370l	687	61788	620 (16)
530	62014	466	614	61596	370m	688	61789	620 (17)
531	62022	403a	615	62142	480	689	61780	620 (21)
532	62021	403b	616	62174	482	690	61781	620 (22)
533	62020	403c	617	62164	404	691	61782	620 (23)
534	62023	403d	618	62146	359	692	61828	620 (18)
536	61759	577	619	61603	370t	693	61829	620 (19)
537	61588	582a	620	62149	524	694	61830	620 (20)
538	61589	620 (52)	621	62136	408	695	61831	587b
539	62003	415	622	61604	370u			

Ausstellung	JE	Carter	Ausstellung	JE	Carter	Ausstellung	JE	Carter
696	61791	620 (24)	772	61025	329i	861-3	61568	370ww
697	61867	399b	773	61042	322h	864-7	61554	370tt
698	61868a	620 (28)	774	61039	322j	868-71	61567	370vv
699	61868b	620 (27)	775	60955	328d	872-6	61556	370uu
700	61792	587d	776	60962	328b	877-84	61557	370vv
701	61832	620 (25)	777	60968	328n ?	885	62543	620 (56)
702	61784	620 (26)	778	60954	328g ?	886	62465	620 (56)
703	61383	589	779	61050	330m	887	62552	620 (56)
704	61392	338	780	61049	330l	888	62466	620 (56)
705	61393	440a	781	61045	329l	889-90	62570-1	620 (56)
706	61394	616	782	61048	330o ?	892	62539	620 (56)
707	61973	620 (94)	783	60863	323c	893-4	62574-5	620 (56)
708a	61870	585u	784	60855	323a	895	62469	620 (56)
708b	61871	585u	785	60862	323e	896	62467	367g
709	62062	—	786	60861	323f	897	62550	367g
710	61866	620 (67)	787	60851	323n	898	62453	367g
711	61288	620 (68)	788	60869	323k ?	899	61478	575
712	61960	620 (69)	789	60910	324l	900	62057	33
713a	61956	620 (70)	790	60911	324n	901	62047	30
713b	61957	620 (70)	791	60932	324t	902	61501	270
713c	61958	620 (70)	792	60931	324s	903	61471	270
713d	61959	620 (70)	793	60929	319d	905	62398	270c
714	61862	620 (71)	794	60905	324h	906	60823	330c
715	61857	620 (72)	795	60943	319l	907	60837	318c
716	61858	620 (73)	796	60939	319h	908	60831	601
717	61954	620 (76)	797	60852	323l	909	62037	139
718	61953	620 (77)	798	60919	324b	910-1	62688	21a-b
719	61955	620 (78)	799	60906	324i	912-3	62681	21k-l
720	62110	620 (101)	800	60945	319b	914	62629	44q
726	62064	620 (13)	801	60944	319a	914-5	62682	270a-b
727	62109a	620 (105)	802	60909	324k	916	61474	316
728	61389	357	803	60930	323o	917	61452	54
729	61384	422	804	60896	319n	918	61494	115
730	61395	589a	805	60858	323d	919	61324	274
731	61385	367c	806	60898	324g	920	61470	272
732	62011	35	807	60899	324m	921	61455	68
733	61582	545	808	60912	324o	922	61327	277
734	62002	596a	809	60917	324p	923	62133	449
735	62004	389	810	61051	326c	924	62326	502
736	61740	596s ?	811	61053	326e	925	62325	431
737	61652	582b	812	61106	327i	926	61570	48x
738	61446	403	813	61059	326j	927a	61575	—
739	61447	386	814	61063	326n	927b	61574	—
740	61647	607d	815	61137	327dd	928	61516	596t
741	61639	370a	816	61101	326s	929	61542	596p
742	61649	607c	817	61103	326u	930	61543	370ll
743	61650	607h	818	61145	327s	931	62644	21o
744	61482	487	819	61148	327m	932	62645	21ff
748	62113	360	820	61130	327w	933	61989l	120
750	61495	79	821	61159	327g	934	61981	—
750	61495	574	822	61154	327b	935	60671	255
751	61457	547	823	61113	327ff	936	60670	254
751	61457	615	824	61147	327l	937	62643	21aa
752	61456	585	825	61120	327mm ?	938	62630	44q
753	61577	379a	826	61134	327aa	939	62134	339
754	61576	379b	827	61126	327o	939	62134	96a
755	60723	8	828	62075	21ww	940	61546	370mm
756	62034	457	829	62073	389	941	62664	21pp
757	62665	50m	830	61505	228	942	61571	585cc
758	62667	50r	831	61515	241	943	61950	101w
759	62668	43b	832	61510	222	944	S-4476	von 46n ?
760	61930	44bb	833	61508	226	944	62754	44n
761	61929	44bb	834-9	61560	243	945	61904	46b
762	61934	21y	834-9	61560	248	945	S-4472	von 46b ?
763	61933	44dd	840-3	61548	390	946	61905	46c
764	61936	21dd	840-3	61548	430	946	S-4465	von 46c ?
765	61931	44cc	844-7	61549	370ss	947	61908	53a
766	61012	329g	848-50	61550	370nn	947	S-4467	von 53 ?
767	61023	322a	851	61551	370nn	947	S-4468	von 53 ?
768	61019	322i	852-3	61559	370oo	948	61907	21u
769	60992	329a	854	61569	596v	949	61909	46qq
770	61011	329f	855-8	61555	370rr	949	S-4469	von 46qq ?
771	60994	329c	859-60	61552	596v	950	S-4464	von 54r ?

Ausstellung	JE	Carter	Ausstellung	JE	Carter	Ausstellung	JE	Carter
950	61906	54r	1022	62232	461e	1085 (88)	62454	620 (56)
951	61910	46r	1023	62233	461p	1085 (89)	62555	620 (56)
952	61771	370j	1024	62227	461m	1085 (90)	62578	620 (56)
953	61766	232	1025	62221	461g	1085 (91)	62579	620 (56)
954	61773	223b	1026	62225	461k	1085 (92)	62554	620 (56)
955	61669	217b	1027	61641	370c	1085 (93)	62556	620 (56)
956-7	60692	317a	1028	61648	607e	1085		
957	S-4473	von 46rr?	1029	61643	370f	(94-5)	62576-7	620 (56)
958-9	60693	317a1	1030	61640	370b	1085 (96)	62553	620 (56)
960	60694	317a2	1031	61642	370e	1085 (97)	62580	620 (56)
961-2	60695	317b	1032	61644	370g	1085		
963-4	60696	317b1	1033	61645	607b	(98-101)	62558-61	367g
965	61919	269q	1034	61651	607i	1085 (102)	62497	367g
966	61920	269fff	1035	61348	312	1085 (103)	62498	367g
967	61921	269 4a	1036	61479	493	1085 (104)	62468	367g
968	61922	269kk	1036	61479	494	1085 (105)	62455	367g
969	61923	269ggg	1037	61323	274	1085		
970	61924	269hhh	1038	61621	620 (10)	(106-11)	62544-9	367g
971	61925	269xxx	1039	62036	140	1085 (112)	62551	367g
972	61926	269yyy	1040	62347	54ddd 3	1085		
973	61927	269 4b	1041	62647	100f	(113-4)	62572-3	367g
974	61928	269xxx	1042	62676	46o	1086	60820	330a
975	61932	44cc	1043	62677	46p	1087	60822	330d
976	61879	256i 2	1044	62707	119c	1088	60839	325b
977	61491	367k	1045	62679	50p	1089	60829	458
978	61265	620 (94)	1046	62708	50r	1090	60832	620(113)
979	61682	135q	1047	61472	279	1091	60853	323m?
980	61739	596i	1048	61473	315	1092	60923	324c?
981	61625	—	1049	61475	317	1093	60926	324f
982	62045	378	1050	61681	596g	1094	60925	324e
983	62030	351	1051	61714	468o	1095	60924	324d
984	60687	266b	1052	61744	468h	1096	60872	323i
985	60686	266	1053	61745	468j	1097	60864	323j?
985	60686	266a	1054	61746	468g	1098	60865	319g
986	62276	406	1055	61747	468e	1099	60870	323g
987	62156	353	1056	61711	468n	1100	60871	323h?
988	62141	485	1057	61615b	620 (7)	1101	60928	319e
989	62177	603	1058	61602	370n	1102	60895	319c
990	62176	448	1059	61600	370s	1103	60942	319k
991	62175	479	1060	61599	370q	1104	60940	319i
992	62171	343	1061	61601	370t	1105	60918	324a
993	60715	289a	1062	61597	370o	1106	60854	319f
994	60710	275e	1063	61598	370p	1107	60856	323b
995	60713	275d	1064	60703	288	1108	60908	324j
996	60731	289c	1065	62015	377	1109	60897	323p
997	62092	585bb	1066	61579	350	1110	60901	324r?
998	62091	585bb	1067	61583	566	1111	60907	319o
999	62087	367l	1068	61581	488a	1112	60900	324q?
1000	62089	367m	1069	61580	492	1113	60875	319m
1001	62088	620 (89)	1070	61578	488b	1114	60956	328c
1002	62086	620 (90)	1071	62634	21d	1115	60982	328m
1003	62090	620 (91)	1072	62648	21p	1116	60980	328i
1004	62085	620 (92)	1073	62650	21r	1117	60979	328h
1005	62096	620 (65)	1074	62653	44w	1118	60988	328k
1006	61809		1075	62651	21aa	1119	60965	328e?
(1-15)	-23	367q	1076	62652	21jj	1120	60970	328l
1007 (1-4)	61824-7	367r	1077	62654	46gg	1121	60949	328f?
1007	61793-		1078	62637	54dd 2	1122	60981	328j
(5-14)	806	367r	1079	62649	21q	1123	60985	328a
1008	62179	604	1080	62636	21w	1124	60995	329d
1009	62173	421	1081	62640	21bb	1125	60993	329b
1010	62050	592	1082	62641	21x	1126	61007	322b
1011	62049	442b	1083	62642	21m	1127	61008	322c
1012	62053	442c	1084	61572	585y	1128	61010	329e
1013	62054	414	1084	61573	585y	1129	61026	329j
1014	62246	461y	1085			1130	61027	329k?
1015	62245	461u	(1-8)	62562-9	620 (56)	1131	61009	322d
1016	62223	461i	1085	62499-		1132	61024	329h
1017	62226	461l	(9-48)	538	620 (56)	1133	60991	322f
1018	62220	461f	1085			1134	60990	322e
1019	62229	461o	(76-84)	62456-64	620 (56)	1135	61046	320n
1020	62228	461n	1085			1136	61041	322g
1021	62231	461c	(85-7)	62540-2	620 (56)	1137	61129	327v

Ausstellung	JE	Carter	Ausstellung	JE	Carter	Ausstellung	JE	Carter
1138	61125	326y	1210	61310	316p	1246 (30)	61238	602g (?)
1139	61136	327cc	1211	62633	256eee	1246 (31)	61223	602g (?)
1140	61127	327p	1211	62633	256mn	1246 (31)	61239	602g (?)
1141	61132	327y	1212	61547	247	1246 (32)	61229	602g (?)
1142	61149	327n	1213	62066	—	1246 (32)	61240	602g (?)
1143	61133	327z	1214	62065	—	1246 (33)	61228	602g (?)
1144	61131	327x	1215	62067	—	1246		
1145	61128	327u	1216	60947	—	(33–4)	61252	602g (?)
1146	61064	326o	1217	61980	—	1246 (34)	61227	602g (?)
1147	61124	326w	1218	62068	—	1246 (35)	61226	602g (?)
1148	61123	326v ?	1219	62063	—	1246		
1149	61115	327ii ?	1220	62069	—	(35–6)	61253	602g (?)
1150	61057	326h	1221	62070	—	1246 (36)	61225	602g (?)
1151	61135	327bb	1222	62071	—	1246 (36)	61231	602g (?)
1152	61117	327kk	1223	62271	9	1246 (37)	61224	602g (?)
1153	61112	327ee	1224	62273	23	1246 (37)	61254	602g (?)
1154	61122	325f	1225	62026	547d	1246		
1155	61090	326p	1226	62027	548a	(38–9)	61255	602g (?)
1156	61060	326k	1227	62693	252	1246 (40)	61256	602g (?)
1157	61061	326l ?	1228	62706	261a	1246		
1158	61062	326m	1229	62705	281a	(41–4)	61257	602g (?)
1159	61056	326g ?	1230	62703	291a	1246 (41)	61191	602g (?)
1160	61055	326f	1231	62704	300a	1246 (42)	61192	602g (?)
1161	61058	326i	1232	61378	257	1246 (43)	61193	602g (?)
1162	61118	327ll	1233	61376	258	1246 (44)	61194	602g (?)
1163	61138	327hh ?	1234	61377	259	1246 (45)	61195	602g (?)
1164	61150	327q	1235	61379	260	1246 (46)	61196	602g (?)
1165	61151	327r	1236	61989h–i	122j	1246 (47)	61197	602g (?)
1166	61146	327t	1237	61990h–i	122j	1246 (48)	61198	602g (?)
1167	61105	327h	1238	61989j–k	122l	1246 (49)	61199	602g (?)
1168	61111	327k	1239	61998	150	1246 (50)	61203	602g (?)
1169	61107	327j	1240	62267	—	1246 (51)	61204	602g (?)
1170	61114	327gg	1241	62269	—	1246 (52)	61171	602g
1171	61052	326d	1242	61499	620 (121)	1246 (52)	61205	602g (?)
1172	61121	327nn	1243	61500a–b	1k	1246 (53)	61206	602g (?)
1173	61116	327jj	1246			1246 (53)	61206	602g (?)
1174	61144	326x	(1–2)	61241	602g (?)	1246 (54)	61207	602g (?)
1175	61102	326t ?	1246			1246 (55)	61208	602g (?)
1176	61100	326r ?	(1–15)	61250	602g (?)	1246 (56)	61210	602g (?)
1177	61157	327e ?	1246			1246 (57)	61211	602g (?)
1178	61153	327a	(3–4)	61242	602g (?)	1246 (58)	61212	602g (?)
1179	61158	327f	1246			1246 (59)	61213	602g (?)
1180	61155	327c	(5–6)	61243	602g (?)	1246 (60)	61214	602g (?)
1181	61156	327d ?	1246			1246 (61)	61215	602g (?)
1182	61099	326q	(7–9)	61244	602g (?)	1246 (62)	61216	602g (?)
1183	60941	319j	1246			1246 (63)	61217	602g (?)
1184	60689	266g	(9–11)	61232	602g (?)	1246 (64)	61218	602g (?)
1185	60690	266g	1246			1246 (65)	61219	602g (?)
1186	60691	266g	(10–1)	61245	602g (?)	1246 (66)	61220	602g (?)
1187	62018	586	1246			1246 (67)	61221	602g (?)
1187	62018	600a–d	(12–3)	61246	602g (?)	1247 (1)	61171	602g (?)
1188	60669	235a	1246			1247 (2)	61172	602g (?)
1189	61477	551	(12–21)	61233	602g (?)	1247 (3)	61173	602g (?)
1189	61477	540	1246			1247 (4)	61174	602g (?)
1191	62752	—	(14–5)	61247	602g (?)	1247 (5)	61175	602g (?)
1192	62655	—	1246			1247 (6)	61176	602g (?)
1193	62078	—	(16–7)	61251	602g (?)	1247 (7)	61177	602g (?)
1194	62077	—	1246 (18)	61249	602g (?)	1247 (8)	61178	602g (?)
1195	61295	316a	1246			1247 (9)	61179	602g (?)
1196	61296	316b	(19–20)	61248	602g (?)	1247 (10)	61180	602g (?)
1197	61297	316c	1246			1247 (11)	61181	602g (?)
1198	61298	316d	(19–32)	61250	602g (?)	1247 (12)	61182	602g (?)
1199	61299	316e	1246			1247 (21)	61183	602g (?)
1200	61300	316f	(22–5)	61234	602g (?)	1247 (22)	61184	602g (?)
1201	61301	316g	1246 (26)	61222	602g (?)	1247 (23)	61185	602g (?)
1202	61302	316h	1246 (27)	61209	602g (?)	1247 (24)	61186	602g (?)
1203	61303	316i	1246 (27)	61235	602g (?)	1247 (25)	61187	602g (?)
1204	61304	316j	1246 (28)	61202	602g (?)	1247 (38)	61188	602g (?)
1205	61305	316k	1246 (28)	61236	602g (?)	1247 (39)	61189	602g (?)
1206	61306	316l	1246 (29)	61201	602g (?)	1247 (40)	61190	602g (?)
1207	61307	316m	1246 (29)	61237	602g (?)	1248	62150	620 (122)
1208	61308	316n	1246 (30)	61200	602g (?)	1249	60666	237a
1209	61309	316o	1246 (30)	61230	602g (?)	1250	60667	238a

Ausstellung JE		Carter	Ausstellung JE		Carter	Ausstellung JE		Carter
1251	60687	266c-f	1305 (1)	62296	32n	1365	60885	611b
1252	62617	271	1305 (2)	62295	32n	1366	60937	611c?
1253	62343	272	1305 (3)	62294	32n	1367	60938	517g
1253a	62619	272	1305 (4)	62293	32n	1368	60886	517e?
1253b	62616	272	1305 (5)	62292	32n	1369	60927	418g?
1254	62342	275	1305 (6)	62291	32n	1370	60887	611c?
1254	62613	275	1306	62324	362	1371	60888	611c
1255	62341	279	1307	61939	547b	1372	60894	611c
1255	62612	279	1308	62381	547c	1373	60913	517h
1256	62340	283	1310	61940	620 (123)	1374	60889	611b
1256	62618	283	1311	61485	325	1375	61104	519d
1257	62339	302	1312	61486	326	1376	60806	512c
1257	62590	302	1313	61404	—	1377	60770	608e
1258	62338	304	1314	61400	—	1378	60807	512c
1258	62620	304	1315	61401	62ss	1379	60783	512a
1259	62683	436b	1316	61409	62b	1380	60781	517b
1260	61097	519c	1317	61418	—	1381	60814	517d?
1261	62692	367b	1318	61403	62dd	1382	60761	602a
1262	62691	—	1319	60668	239	1383	60760	496b
1263	62687	—	1320	60667	238	1384	60759	496b
1264a	61883	—	1321	60666	237	1385	60816	512e?
1264b	61882	—	1322	60664	207	1386	60794	608c
1265a	61283	—	1323	60665	208	1387	60799	517c
1265b	61284	—	1324	61993a	161	1388	60797	608c
1265c	61285	—	1324	61993a	163	1389	60803	608a
1265d	61286	—	1325	61991a	103	1391	60768	512d
1267 (1)	62099	620 (80)	1325	61991a	121	1392	60801	608a
1267 (2)	62097	620 (85)	1326	61331	334	1393	60793	512b
1267 (3)	62098	620 (79)	1327	62317	489	1394	60780	517b
1267 (4)	62102	620 (81)	1328	62318	568	1395	60903	418g?
1267 (5)	62100	620 (83)	1329	62335	—	1396	60860	418a
1267 (6)	62101	620 (82)	1330	62336	—	1397	60857	418a
1267 (7)	62103	620 (86)	1331	62337	—	1398	60859	418a
1267 (8)	62743	—	1332	62290	154	1399	60902	418c
1267 (10)	62744	620 (88)	1333	61997	333	1400	60850	418e?
1267 (11)	62742	620	1334	61992d	—	1401	60849	418e
1267 (12)	62753	620	1335	61994d	—	1402	60848	418e
1268	62139	32e	1336	61993d	—	1403	60847	418e
1269	62140	32d	1337	61459	—	1404	60874	418b
1270	62162	32b 4	1338	61464	453	1405	60873	418b?
1271	62178	32g	1339	61460	—	1406	60866	418f?
1272	62187	32f	1340	60804	608a	1407	61080	602f
1273	62180	—	1340	61463	269a	1408	61081	602f
1274	62181	32c	1340	61463	270b	1409	61088	602f
1275	62188	32h	1341	61448	56	1410	61082	602f
1276	62160	32a 2	1342	61480	43	1411	61083	602f
1277	62154	32b 4	1342	61480	522	1412	61089	602f
1278	62161	32b 4	1342	62109b	43	1413	61084	602f
1279	62163	32i	1342	62109b	522	1414	61085	602f
1280	62153	20	1343	62757	—	1415	61086	602f
1281	62152	7	1343	27/3/34/38	585p	1416	61087	602f
1282	62151	7a	1344	62452	53b	1417	60868	418f?
1283	62155	55	1344	62452	43k	1418	60867	418f?
1284	62159	32a 2	1345	62193	—	1419	60935	418d
1286	61935	525	1346	62298	32m	1420	60933	418d
1287	62272	24	1347	60840	496a	1421	60936	418d
1288	62279	614a	1348	62729	198	1422	60904	418d
1289	62280	614b	1349	62076	21.xx	1423	60934	517e
1290	62281	614c	1350	62074	387	1424	60922	517h
1291	62282	614e	1351	60920	517h	1425	60890	611b?
1292	62283	614f	1352	60877	611b?	1426	60891	418g?
1293	62284	614g	1353	60878	611c	1427	60892	611b
1294	62285	614h	1354	60879	517f?	1428	60876	611c
1295	62286	614i	1355	60880	611b	1429	60986	459b
1296	62278	614k	1356	60881	611c	1430	61162	519e?
1297	62277	—	1357	60882	611a?	1431	61163	519e
1298	62287	—	1358	60921	517h	1432	61164	519e
1299	62189	620 (2)	1359	60883	611b?	1433	61140	496e
1300	62072	620 (1)	1360	60914	611a?	1434	61152	496e?
1301	62055	613	1361	60915	611a?	1435	61044	605b
1302	62288	106b	1362	60916	611a?	1436	61043	605a
1303	62289	15a	1363	60893	517f?	1437	61141	496e
1304	62297	86	1364	60884	611c?	1438	61139	496e

Ausstellung	JE	Carter	Ausstellung	JE	Carter	Ausstellung	JE	Carter
1439	61161	519f	1512	60775	517a	1580 (6)	62723	526
1440	61022	605c	1513	60785	512a	1580 (6)	62723	573f
1441	60811	512e	1514	60805	608a	1580 (6)	62723	616
1442	60773	608e	1515	60778	517b	1580 (7)	62717	348
1443	60818	608c	1516	61094	602f	1580 (7)	62717	400
1444	60772	608e	1517	61073	602f	1580 (8)	62718	589
1445	60815	608d	1518	61065	602f	1580 (8)	62718	591
1446	60792	608c	1519	61074	602f	1580 (9)	62721	365
1447	60813	608d	1520	61075	602f	1580 (9)	62721	341
1448	60771	512d	1521	61076	602f	1580 (9)	62721	347
1449	60817	512e	1522	61077	602f	1580 (9)	62721	372
1450	60769	512d	1523	61078	602f	1580 (9)	62721	381
1451	60812	512e	1524	61079	602f?	1580 (9)	62721	384
1452	61020	605c	1525	60842	602c	1580 (9)	62721	396
1453	61165	519f	1526	60841	602e	1580 (9)	62721	416
1454	61166	519f	1527	60846	602b	1580 (9)	62721	419
1455	61119	496e?	1528	60977	459f	1580 (9)	62721	427
1456	61142	496e	1529	60997	514c	1580 (9)	62721	440a-c
1457	61047	380a	1530	60998	514c	1580 (9)	62721	446
1458	61143	496e	1531	61109	496d	1580 (9)	62721	450
1459	61110	496d	1532	61006	337b	1580 (9)	62721	452
1460	61167	519f	1533	61028	514a	1580 (9)	62721	471
1461	61168	519f	1534	60973	459f	1580 (9)	62721	472
1462	61160	519e	1535	61015	605e	1580 (9)	62721	474
1463	60978	459f?	1536	61037	337a	1580 (9)	62721	504
1464	60999	337c	1537	60776	608d	1580 (9)	62721	521
1465	61000	337c	1538	60758	496b	1580 (9)	62721	532
1466	61005	605g	1539	60763	602a?	1580 (9)	62721	533
1467	61033	514a?	1540	60766	496c?	1580 (9)	62721	534
1468	61001	337c	1541	60762	602a?	1580 (9)	62721	538
1469	61034	337a	1542	60767	496c	1580 (9)	62721	553a-b
1470	61035	337a	1543	60782	512a?	1580 (9)	62721	554
1471	60996	514d	1544	61030	605d	1580 (9)	62721	555
1472	61021	605c	1545	61029	605d	1580 (9)	62721	559a-b
1473	60810	512c	1546	60951	459e?	1580 (9)	62721	565
1474	60790	608c	1547	61031	514a?	1580 (9)	62721	569
1475	60777	517d?	1548	61036	337a	1580 (9)	62721	573a
1476	60819	608c	1549	61108	496d	1580 (9)	62721	573d-e
1477	60796	608b	1550	61032	514a?	1580 (10)	62720	369
1478	60795	608b	1551	61038	337a	1580 (10)	62720	426
1479	60798	608c	1552	60969	380f	1580 (10)	62720	429
1480	60784	512a	1553	60984	459d	1580 (10)	62720	470
1481	60791	608c?	1555	60963	459a	1580 (10)	62720	527a
1482	60802	608a	1556	60964	459a	1580 (10)	62720	528
1483	60774	517a	1557	60948	459g	1580 (10)	62720	530
1484	61040	605f	1558	60950	459e?	1580 (10)	62720	542
1485	61002	605g?	1559	60952	459e	1580 (10)	62720	544
1486	61003	605g	1559	60966	380d	1580 (10)	62720	567
1487	61004	605g?	1560	60961	459e	1580 (10)	62720	573b
1488	61013	337b	1561	60960	380d	1580 (11)	62719	342
1489	61016	514b	1562	60957	380c	1580 (11)	62719	441
1490	61017	514b	1563	60958	380b	1580 (11)	62719	506
1491	61018	514b	1564	61095	519b	1580 (11)	62719	562
1492	61014	605e	1565	61098	519c	1580 (12)	62714	47b
1493	60845	602d	1566	61054	519a	1580 (12)	62714	573c
1494	60844	602d	1567	61096	519c	1580 (13)	62716	364
1495	60843	602e	1568	60989	380f	1580 (13)	62716	371
1496	61091	602f	1569	60974	380g	1580 (13)	62716	451
1497	61092	602f	1570	60971	459f	1580 (13)	62716	518b
1498	61093	602f	1571	60975	459f	1580 (14)	62722	32
1499	61066	602f	1572	60987	380e	1580 (15)	62715	348
1500	61067	602f	1573	60976	459f	1580 (15)	62715	356
1501	61068	602f	1574	60972	459f	1580 (15)	62715	368
1502	61069	602f	1575	60983	459d	1580 (15)	62715	400
1503	61070	602f	1576	60967	459a?	1580 (15)	62715	484
1504	61071	602f	1577	60959	459e	1580 (15)	62715	527b
1505	61072	602f	1578	60953	459c	1580 (16)	62713	439
1506	60809	512b?	1579	62031	82	1580 (16)	62713	473
1507	60788	512a	1580 (1)	62733	254a	1580 (16)	62713	531
1508	60787	512a?	1580 (2)	62736	297a	1580 (17)	62712	355
1509	60786	512a?	1580 (3)	62735	282a	1580 (17)	62712	401
1510	60800	512c	1580 (4)	62734	255a	1580 (20)	62737	313
1511	60789	608c	1580 (5)	62731	142	1580 (21)	62739	313

Ausstellung	JE	Carter	Ausstellung	JE	Carter	Ausstellung	JE	Carter
1580 (22)	62738	313	1649	62670	89a	3035	61256	602g (?)
1581	60704	438-65	1650	62709	79c	3036	61257	602g (?)
1581	60705	438-65	1651	62646	21gg	3038	61258	602g (?)
1581	60706	438-65	1653	61662	582g	3039	61259	602g (?)
1582	62044	511	1654	61663	582h	3040	61260	602g (?)
1583	61594	370z	1655	61664	619a	3041	61261	602g (?)
1584	61619	620 (12)	1656	62698	256uuuu	3042	61262	602g (?)
1585	62005	599	1657	62700	256nnnn	3043	61427	—
1586	62006	600	1658	62726	205	3044	61443	—
1587	61506	247	1659	62725	18	3045	61417	62m
1588	61507	244	1660	62724	17	3046	61442	62w
1589	61504	48e (1?)	1661	62732	—	3047	61441	62u
1590	61503	77a	1662	62663	44b	3048	61398	62? w
1591	61511	246	1663	62635	21d	3049	61397	?
1592	61513	225b	1664	62701	50c	3050	61396	62j
1593	61514	225a	1665	62662	101s	3051	61399	62? ww
1594	61512	70	1666	62625	367i	3052	61408	62s
1595	61509	234	1667	62666	50s	3053	61416	62f
1596	61532	596k	1668	62656	50a	3054	61440	—
1597	61531	596m	1669	62624	—	3055	61424	—
1598	61538	370kk	1670	62747	168	3056	61428	—
1599	61518	596q	1671	62748	148a	3057	61423	62o
1600	61530	370ii	1672	62749	148b	3058	61413	62t
1601	61536	596l	1673	62750	148c	3059	61419	62ff
1602	62042	149	1674	62628	587	3060	61438	62ii
1603	61748	468i	1675	62334	—	3061	61439	62ll
1604	61749	—	1676	62344	271	3062	61407	62d
1605	61750	468c	1677	62299	503	3063	61437	62cc
1606	61751	468e	1677	62300	500	3064	61436	62gg
1607	61752	468d	1678	62301	523	3065	61406	62q
1608	61712	468m	1679	62302	490	3066	61435	62vv
1609	61710	468l	1680	62303	486	3067	61420	62u
1610	61709	468k	1681	62304	434	3068	61434	62tt
1611	61718	231a	1682	62305	392	3069	61429	62r
1612	61719	216a	1683	62306	413	3070	61415	62oo
1613	61717	216b	1684	62307	511	3071	61411	62l
1614	61716	231b	1685	62308	560	3072	61421	62ee
1615	61772	223a	1686	62312	(509)	3073	61410	62e
1616	61768	217a	1687	62313	508	3074	61426	62v
1617	61767	219	1688	62331	—	3075	61422	62aa
1618	61668	221	1689	62332	—	3076	61414	62rr
1619	61765	236	1690	62333	—	3077	61412	62n
1620	61724	230	1691	61991b-c	107	3078	61405	62ff
1621	61769	135x	1692	61991d	—	3079	61425	62qq
1622	61679	596d	1693	61991e-f	162a-b	3080	61402	62a
1623	61698	596f	1694	61991h	122k	3081	61433	62y
1624	61700	50ww	1695	61993e	—	3082	61432	62g
1625	61699	48q	1696	61993b-c	155	3083	61431	62b?
1626	61703	48v	1696	61993b-c	164	3084	61430	—
1627	61702	48s	1697	61989m	121z	3085	61355	460
1628	61672	48p	1698	61990j	103a	3086	61360	375
1629	61701	48w	1699	61991g	156	3087	61361	463
1630	61646	—	1700	62756	—	3088	61362	481
1631	61484	322	1701	61992a	333	3089	61351	581
1632	61483	318	1701	61992b-c	333	3090	61359	556
1633	61487	328	1701	61992f	333	3091	61358	610
1634	61488	329	1702	62745a	209	3092	61357	617
1635	61386	93	1702	62745b	209	3093	61353	612
1636	61387	117	3000	61243	602g (?)	3094	61356	609
1637	61388	129	3001	61241	602g (?)	3095	61352	462
1638	61558	370zz	3002	61242	602g (?)	3096	61354	491
1639	61451	587	3003	61245	602g (?)	3097	61333	572
1639	61451	367	3004	61244	602g (?)	3097	61333	513
1640	61453	330	3005	61246	602g (?)	3098	61341	273
1641	61450	550	3006	61247	602g (?)	3099	61337	491
1641	61450	546	3008	61250	602g (?)	3099	61337	437
1642	61636	50cc	3020	61230	602g (?)	3100	61332	598
1643	61635	50y	3024	61234	602g (?)	3100	61332	332
1644	61631	50zz?	3025	61231	602g (?)	3101	61342	597
1645	61633	50—?	3027	61237	602g (?)	3102	61340	287
1646	62632	21t	3029	61252	602g (?)	3103	61329	276
1647	62639	101p	3032	61254	602g (?)	3104	61349	464
1648	62669	50u	3033	61255	602g (?)	3106	61346	307

Ausstellung	JE	Carter	Ausstellung	JE	Carter	Ausstellung	JE	Carter
3107	27/3/34/37	—	3279	29/3/34/71	101v	3328	29/3/34/	
3108	61541	596o	3280	29/3/34/98	44x		69a-e	101k
3109	61540	596n	3281	29/3/34/51	21ll	3329	29/3/34/	
3110	61527	135z	3282	30/3/34/15	79u8		67a-c	101i
3111	61529	370jj	3283	30/3/34/05	79s	3330	29/3/34/53	46tt
3112	61539	596r	3284	29/3/34/97	21tt	3331	29/3/34/52	21xx
3113	61520	48g	3285	30/3/34/16	89b	3332	29/3/34/	
3114	61528	370ff	3286	30/3/34/17	43e		66a-b	101h
3115	61535	596s	3287	29/3/34/05	54f	3333	29/3/34/	
3116	61534	370hh	3288	29/3/34/			64a-b	101b
3117	61522	153		33a-o	50m	3334	29/3/34/	
3140	61521	370gg	3289	29/3/34/			68a-c	101j
3141	61519	77b		30a-d	46i	3335	29/3/34/65	101f
3165	27/3/34/01	85b	3290	29/3/34/34	50r	3336	29/3/34/	
3171 (8)	61553	370ww	3291	29/3/34/35	101aa		63a-b	101a
3172 (1,2)	61553	370xx	3292	29/3/34/		3337	29/3/34/70	299a
3185	28/3/34/82	46a1		32a-f	46k	3338	29/3/34/	
3189	28/3/34/81	100e	3293	29/3/34/			54a-c	50c
3190	28/3/34/			31a-d	46j	3339	29/3/34/	
	01-80	50yy	3294	29/3/34/			104	46h
3190	28/3/34/			15a-i	46d	3340	29/3/34/99	101d
	01-80	65a	3295	29/3/34/		3341	29/3/34/	
3191	28/3/34/			16a-l	46e		105	21ss
	109-17	50yy	3296	29/3/34/		3342	29/3/34/49	100h
3191	28/3/34/			12a-e	43m	3343	29/3/34/48	101z
	109-17	65a	3297	29/3/34/07	21nn	3344	29/3/34/36	21ii
3192	28/3/34/		3298	29/3/34/19	46l	3345	30/3/34/06	43v
	102-8	147c	3299	29/3/34/09	43f	3346	29/3/34/	
3193	28/3/34/		3300	29/3/34/26	79b		61a-c	79l
	90-101	148/149	3301	29/3/34/		3347	30/3/34/	
3224	29/3/34/			24a-ad	50l		04a-h	21hh
	62a-b	79u	3302	29/3/34/		3348	29/3/34/	
3228	27/3/34/03	503?		17a-i	46f		103a-e	21uu
3228-9	62614-5	—	3303	29/3/34/		3349	29/3/34/	
3230-41	62591-602	—		25a-i	50r		102a-u	79l
3231	61994a	332	3304	29/3/34/		3350	29/3/34/	
3238	29/3/34/01	44t		23a-e	50g		107a-j	79d1-10
3239-40	61994b-c	332	3305	29/3/34/11	43h	3351	30/3/34/03	46mm
3241	61994e	332	3306	29/3/34/		3352	30/3/34/01	79n
3242	62604	—		29a-f	101g	3353	29/3/34/	
3243	62603	—	3307	29/3/34/13	43n		100a-o	101e
3244	62588	—	3308	29/3/34/		3354	30/3/34/	
3245	62589	—		10a-b	43g		02a-ai	79i
3246	62609	—	3309	29/3/34/14	43o	3355	29/3/34/	
3247-50	62605-8	—	3310	29/3/34/27	79m		101a-i	79k
3251	62610	—	3311	29/3/34/		3356	29/3/34/	
3252	62611	—		28a-d	101c		60a-c	79k
3254	62622	—	3312	29/3/34/		3356	29/3/34/	
3255	62623	—		08a-g	43c		106	79j
3256	62621	—	3313	29/3/34/20	46uu	3357	29/3/34/87	293a
3257	62581	620 (104)	3314	29/3/34/		3358	29/3/34/93	301a
3258	62582	620 (107)		18a-g	46g	3359	29/3/34/94	303a
3259	62583	620 (103)	3315	29/3/34/47	271e	3360	29/3/34/90	297a
3260	62584	620 (97)	3316	29/3/34/42	79t	3361	29/3/34/86	292a
3261	62585	620 (102)	3317	29/3/34/		3362	29/3/34/92	300a
3262	62586	620 (99)		39a-e	43l	3363	29/3/34/85	291a
3263	62587	620 (98)	3318	29/3/34/		3367	29/3/34/77	280a
3264	29/3/34/02	44r		40a-l	79o	3368	29/3/34/76	275e
3265	30/3/34/07	54d	3319	29/3/34/		3369	29/3/34/74	275c
3265	30/3/34/07	54o		45a-b	585x	3370	29/3/34/73	275b
3266	30/3/34/08	54i	3320	29/3/34/46	101l	3371	29/3/34/75	275d
3267	30/3/34/09	46nn	3321	29/3/34/38	43d	3379	29/3/34/72	21v
3268	30/3/34/10	92g	3321	29/3/34/		3380	29/3/34/95	585x
3269	30/3/34/11	—		41a-e	79p	3381	30/3/34/46	585x
3270	30/3/34/12	79r	3322	29/3/34/44	79u2	3382	29/3/34/56	50f
3271	30/3/34/13	21vv	3323	29/3/34/		3383	29/3/34/57	50f
3272	29/3/34/96	101r		43a-d	79u	3384	29/3/34/59	50n
3273	29/3/34/50	21ee	3325	29/3/34/		3385	29/3/34/58	50f
3274	29/3/34/03	21cc		37a-j	21qq	3386	29/3/34/55	50d
3275	29/3/34/04	44t	3326	29/3/34/		3387	30/3/34/19	373
3276	29/3/34/06	44jj		21a-c	50b	3387	30/3/34/19	453b
3277	30/3/34/18	54v	3327	29/3/34/		3387	30/3/34/19	620 (119)
3278	30/3/34/14	44dd		22a-c	50f	3388	30/3/34/20	453b

Ausstellung	JE	Carter	Ausstellung	JE	Carter	Ausstellung	JE	Carter
3388	30/3/34/20	620 (119)	3397	30/3/34/29	620 (119)	3406	30/3/34/38	453b
3388	30/3/34/20	373	3398	30/3/34/30	373	3406	30/3/34/38	620 (119)
3389	30/3/34/21	373	3398	30/3/34/30	453b	3407	30/3/34/39	373
3389	30/3/34/21	453b	3398	30/3/34/30	620 (119)	3407	30/3/34/39	453b
3389	30/3/34/21	620 (119)	3399	30/3/34/31	373	3407	30/3/34/39	620 (119)
3390	30/3/34/22	373	3399	30/3/34/31	453b	3408	30/3/34/40	373
3390	30/3/34/22	453b	3399	30/3/34/31	620 (119)	3408	30/3/34/40	453b
3390	30/3/34/22	620 (119)	3400	30/3/34/32	373	3408	30/3/34/40	620 (119)
3391	30/3/34/23	373	3400	30/3/34/32	453b	3409	30/3/34/41	373
3391	30/3/34/23	453b	3400	30/3/34/32	620 (119)	3409	30/3/34/41	453b
3391	30/3/34/23	620 (119)	3401	30/3/34/33	373	3409	30/3/34/41	620 (119)
3392	30/3/34/24	373	3401	30/3/34/33	453b	3410	30/3/34/42	373
3392	30/3/34/24	453b	3401	30/3/34/33	620 (119)	3410	30/3/34/42	453b
3392	30/3/34/24	620 (119)	3402	30/3/34/34	373	3410	30/3/34/42	620 (119)
3393	30/3/34/25	373	3402	30/3/34/34	453b	3411	30/3/34/43	373
3393	30/3/34/25	453b	3402	30/3/34/34	620 (119)	3411	30/3/34/43	453b
3393	30/3/34/25	620 (119)	3403	30/3/34/35	373	3411	30/3/34/43	620 (119)
3394	30/3/34/26	373	3403	30/3/34/35	453b	3412	30/3/34/44	373
3394	30/3/34/26	453b	3403	30/3/34/35	620 (119)	3412	30/3/34/44	453b
3394	30/3/34/26	620 (119)	3404	30/3/34/36	373	3412	30/3/34/44	620 (119)
3395	30/3/34/27	94a	3404	30/3/34/36	453b	3413	30/3/34/45	104a
3396	30/3/34/28	373	3404	30/3/34/36	620 (119)	3414	30/3/34/47	—
3396	30/3/34/28	453b	3405	30/3/34/37	373	3414	30/3/34/47	172
3396	30/3/34/28	620 (119)	3405	30/3/34/37	453b	entfällt	61469	entfällt
3397	30/3/34/29	373	3405	30/3/34/37	620 (119)			
3397	30/3/34/29	453b	3406	30/3/34/38	373			

INDEX ZUM JOURNAL D'ENTRÉE

(nach Objekten alphabetisch geordnet)

- Amset, Statuette des Gottes 60727
Amulett, Goldblech 61835–47,
61852, 61854–6
Amulett, Herz mit Benu-Vogel 61865
Amulett, Horus 61864
Amulett, Kopfstütze 61869
Amulett, Muschel 61862
Amulett, Papyrus-Säulen
61857–61
Amulett, Schlangen 61848–56
Amulett, Thot 61863
Amulette 61774–874
Anch-Zeichen 61790–2, 87857
Anubis-Symbole 61374–5
Armbänder, Elfenbein 62405–14
Armbänder, Fayence 62360–74,
62380–96
Armbänder, Holz 62421–4
Armbänder, Horn 62425
Armbänder, Leder 62426–7,
62757–61
Armbänder, Stein 62397–404
Atum, Statuette des Gottes 60734
Axt (Dächsel) 61292–4
- Bahre 60669
Bahrtuch, Stütze für das 60665
Benu-Vogel auf Skarabäus 61977
Betten 62012–9
Beutel 62707–8
Binsen, Bündel von 62732
Blei, Probe von 62743
Bleiglanz 62753
Bogen, lang 61503–16
Bogen, zusammengesetzt 61517–45
Bogenkasten 61501–2
Bogensehnen 61546–7
Boote 61328–73
Brote 62710–1
Bumerangs 61592–622
- Chepre, Statuette des Gottes 60737
Cherep-Szepter 61759
- Datteln 62715
Decke vom Wagen 62746
Diadem der Mumie 60684
Djed-Amulett 61778–85
Dolche 61584–87
Duamutef, Statuette des Gottes
60728–9
- Eisen-Werkzeug 61295–310
Ellen 61315–20
Fächer 61999–206
Fackelhalter 62353–7
Falken auf Standarten 60747–8
Farben 62097–103
- Feuerbohrer 61322
Fingerhülsen 60680–1
Fingerschutz aus Stoff 62678
Flagella 62000–01
Fliegenwedel 62747–50
Fußbänkchen 62045–55
- Gans, Statuette einer 60748
Geb, Statuette des Gottes 60735
'Geißel des Osiris' 61760–1
Gemehsu, Statuette des 60748
Gemüse 62712–38
Gerste 62712–3
Getreide 62712–4
Getreidemühle 61326
Getreidespeicher, Modell 61327
Gewand, groß ('Dalmatika')
62625–6
Goldmaske 60672
Goldsarg 60671
Gürtel der Mumie 60676–7
- Haar der Teje 60701
Hacke, Modell (Fayence) 61163–229
Hacke, Modell (Holz) 61169–82
Hacke, Modell (Kupfer) 61230–40
Halskragen, Pektoral, Anhänger
61875–960
Halsschmuck 61939–40, 61961
Handgelenkschutz 61571, 61658–60
Handschuhe 62669–77
Hapi, Statuette des Gottes 60726
Haroeris, Statuette des Gottes 60746
Hor-chenti-chem, Statuette des
Gottes 60745
Horus, Statuette des Gottes 60744
- Ihi, Statuette des Gottes 60731–2
Inschriften auf Stoffstücken 62703
Inventar-Schilder 62104–10,
62581–7
Isis, Statuette der Göttin 60734
Isis-Knoten-Amulett 61828–34
- Joche, Modell (Kupfer) 61258–63
- Kampfstöcke 61654–64
Kanopenkasten, usw. 60686–91
Kanopensärg 60688–91
Kastagnetten 62064
Kasten, halbrund 61495
Kästen, kartuschenförmig
61490–3
Kästen, mit Naosdach 61476–80
Kästen, rechteckig 61446–61
Kästen, mit rundem Deckel
61462–71
Kasten, mit rundem Deckel 61494
- Kästen, mit Satteldach 61445,
61472–5
Kästen, schwarz, für Uschebtis
61484–8
Kästen, Teile 61496
Kästen, tragbar 61444–5
Kebehenuief, Statuette des Gottes
60730
Kette 61981
Keule, Zeremonial- 61623–4
Kissen 62056
Kissen (vom Kopf des Königs)
62698
Knüppel, kurz, gebogen
61638–51
Knüppel, lang, gerade 61625–37
Knüppel, Stöcke, Stäbe,
Szepter 61765–73
Köcher 61570
Kohl-Behälter 62350
König (?), Büste 60722
König, Kopf auf Lotosblüte
60723
König, lebensgroße Statue
60707–8
Königin (?), Büste 60722
Kopfbinde der Mumie 60674–5
Kopfring aus Textilien 62700
Kopfstützen 62020–7
Kopftuch 62665
Körbe 61380–95
Körbe für Kampfstöcke
61658–60
Körbe, Modell (Fayence)
61241–51
Körbe, Modell (Kupfer)
61252–7
Korn-Osiris 60703
Kragen von Kleidung 62643–4
Krummschwerter (Chepesch)
61588–91
Krummstäbe 61731
'Krummstab des Osiris' 61762–4
Kränze 62733–6
Kuh, Kopf der Hathor- 60736
- Lampe 62111
Leichtentücher 62694–7, 62702
Lendentücher 62667–8
Leopardenfell, Imitation 62630
Leopardenkopf von
Kleidungsstück 62629, 62631
- Magische Figuren von den
Grabwänden 61376–9
Mamu, Statuette des Gottes 60738
Maske, (Goldmaske) 60672
Melonen-Kerne 62720

- Messer 61270–88
 Metallplättchen 62640, 62649–52, 62654–5
 Mieder 62627
 Mumienstreifen 60673, 60685
- Nabq* Frucht 62721
 Nephthys, Statuette der Göttin 60725
 Netjeranch, Statuette der Schlange 60754
- Ohrschmuck 61968–73, 62378 (?)
 Onuris-Schu, Statuette des Gottes 60733
 Osiris, König auf Bahre als 60720–1
 Osiris-Bett 60703
- Palmwedel 61757–8
 Panzer 62628
 Papyrusmark 62737–8
 Papyrusglätter 62095
 Pavillon 60704–6
 Peitschen 61995–7
 Perlen, Schnüre mit 61929–38
 Perlenstickerei 62634, 62636–8, 62751–2
 Persea-Blätter 62724–31
 Persea-Früchte 62723
 Pfeile 61548–69
 Ptah, Statuette des Gottes 60739
- Res-Zeichen 61774–7
 Ringe 61962–7, 62375–8
 Ringe, Finger-, Fayence 62452–78
 Ringe, Finger-, Gold usw. 62428–34, 62436–41
 Ringe, Finger-, Harz 62435
 Rohr, Imitation aus Gold 61729
 Rohr, lang, goldverziert 61728
 Rosetten vom Bahrtuch 62745
 Rosetten von Gewändern 62648–9
 Ruder 61363–73
- Saatgut 62717–21
 Salbengefäß, (Doppelgefäß) 61496
 Sandalen 62680–92
 Sandalen (Gold) der Mumie 60678–9
 Sarg für das Haar der Teje 60697–701
 Sarg, innerer (Goldsarg) 60671, 87850
 Sarg, mittlerer 60670
 Särge für Föten 60692–6
 Särge, Kanopen- 60688–91
 Schal, großer 62655–6
 Schals und Halstücher 62657–64
 Schilde 61576–83
 Schlangen auf Standarten 60750–1
 Schlegel, Modell 61321
 Schleudern 61572–5
 Schreibbinse, Imitation 62096
 Schreibbrett 62073–8
- Schreibrohrbehälter 62094
 Schreibunterlage 62079–93
 Schrein für Elle 61482
 Schrein, 1. von außen 60664
 Schrein, 2. von außen 60666
 Schrein, 3. von außen 60667
 Schrein, 4. von außen 60668
 Schrein, die vier großen Schreine 87851
 Schrein, Gold-Schrein für Statuette 61481
 Schrein für Schlange auf Standarte 60751, 60753
 Schreine, zwei auf einer Standfläche 61489
 Schurzstück 60685
 Sendet, Statuette der Göttin 60740
 Sessel 62028–34
 Sichel 61264–5
 Siebe 61323–5
 Siegel von Kästen usw. 62588–624
 Siegel von Vasen 62331–45
 Sistra 62009–10
 Skarabäen 61974–7
 Skarabäus 61872
 Sopdu, Statuette des Gottes 60747
 Spachtel 61291
 Spangen aus durchbrochenem Goldblech 61982–7, 87847–9
 Speise usw. 62710–23
 Spiegel 62346–9
 Spiele 62057–71
 Stäbe 61668–71
 Stäbe 61732–40
 Stäbe mit Statuetten des Königs 61665–6
 Stäbe, gebogen 61741–56
 Stäbe, gerade 61720–2
 Stäbe, gerade, vergoldet 61716–20
 Stäbe, gerade, vergoldete Enden 61709–15
 Stäbe, Gold auf Metall-Kern 61726
 Stäbe, knotig 61727
 Stäbe, Rinden-Dekoration 61672–708, 61723, 61725
 Statuetten des Königs 60709–20
 Statuetten von Göttern 60724–57
 Stöcke — 61652–3
 Stöcke — 61668–71
 Stöcke — 61732–40, 61765
 Stöcke — 61768–71
 Stöcke — 61772–3
 Stöcke, Knüppel, Szepter und Stäbe 61625–58
 Stöcke, Knüppel, Szepter und Stäbe 61765
 Stöcke, Knüppel, Szepter und Stäbe 61773
 Sträuße 62724–30
 Stühle 62035–44
 Stütze für das Bahrtuch 60665
 Szepter 61759
- Tata, Statuette des Gottes 60741
 Tatenen, Statuette des Gottes 60742
 Textilien 62632, 62639–47, 62654, 62656–79, 62679, 62693
 Thot, Statuette des Gottes 60743
 Tierschwanz 62633
 Toiletten-Gefäß in Form einer Gans 62352
 Trompeten 62007–8
- Uschebtis, Alabaster 60948–89
 Uschebtis, Fayence (beige) 61153–68
 Uschebtis, Fayence (blau) 61051–2, 87852–4
 Uschebtis, grauer Granit 61039–42
 Uschebtis, groß, vergoldet 60820–38
 Uschebtis, Holz 60946–7
 Uschebtis, Holz bemalt 60847–95
 Uschebtis, Holz bemalt und vergoldet 60841–6
 Uschebtis, Holz vergoldet 60758–19
 Uschebtis, Kalkstein 61043–50
 Uschebtis, Quarzit 60990–1038
- Vase zwischen zwei Pylontürmen 62359
 Vase, Deckel aus Kupfer 62193
 Vasen, Alabaster 62111–87, 62189
 Vasen, Elfenbein 61197–8
 Vasen, Fayence 62202–69, 87856
 Vasen, Glas 62199–201
 Vasen, Gold 62190
 Vasen, Hes-Form 62237–46, (62193)
 Vasen, Holz 62195–6
 Vasen, Keramik 62270–329
 Vasen, Libations- 62202–36, 87855
 Vasen, Silber 62191–2
 Vasen, Stein außer Alabaster 62166, 62188
 Vogel auf Eiern 62072
 Vorrats-Behälter 61396–443
- Wacholderbeeren 62717–18
 Wachs-Vögel 60756–57
 Wagen 61989–94, 61998 (?)
 Was-Amulett 61786–9
 Was-Szepter 61766–7
 Wehem-Amulett 61793–827
 Weihrauch 62741
 Weinkrüge 62300–29
 Werkzeug, Modell und andere 61169–327
 Werkzeuge (?) —-form 61266–9
 Wetzstein 61311–4
 Wurfhölzer (s. auch Bumerangs) 61615–22
- Zehenhülsen 60682–3
 Ziegel zum Halten einer Fackel 62357
 Zinn, Probe von 62744
 Zwiebel 62722

INDEX ZUM JOURNAL D'ENTRÉE

(nach JE-Nummern geordnet)

- 60664 Schrein, 1. von außen
 60665 Stütze für das Bahrtuch
 60666 Schrein, 2. von außen
 60667 Schrein, 3. von außen
 60668 Schrein, 4. von außen
 60669 Bahre
 60670 Sarg, mittlerer
 60671 Sarg, innerer (Goldsarg)
 60672 Maske, (Goldmaske)
 60673 Mumienstreifen
 60674–5 Kopfbinde der Mumie
 60676–7 Gürtel der Mumie
 60678–9 Sandalen (Gold) der Mumie
 60680–1 Fingerhülsen
 60682–3 Zehenhülsen
 60684 Diadem der Mumie
 60685 Schurzstück
 60685 Mumienstreifen
 60686–91 Kanopenkasten, usw.
 60688–91 Kanopensärge
 60692–6 Särgel für Föten
 60697–701 Sarg für das Haar der Teje
 60701 Haar der Teje
 60703 Korn-Osiris
 60704–6 Pavillon
 60707–8 König, lebensgroße Statue
 60709–20 Statuetten des Königs
 60720–1 Osiris, König auf Bahre als
 60722 König (?), Büste
 60722 Königin (?), Büste
 60723 König, Kopf auf Lotosblüte
 60724–57 Statuetten von Göttern
 60725 Nephthys, Statuette der Göttin
 60726 Hapi, Statuette des Gottes
 60727 Amset, Statuette des Gottes
 60728–9 Duamutef, Statuette des Gottes
 60730 Kebehsenuf, Statuette des Gottes
 60731–2 Ihi, Statuette des Gottes
 60733 Onuris-Schu, Statuette des Gottes
 60734 Atum, Statuette des Gottes
 60734 Isis, Statuette der Göttin
 60735 Geb, Statuette des Gottes
 60736 Kuh, Kopf der Hathor
 60737 Chepre, Statuette des Gottes
 60738 Mamu, Statuette des Gottes
 60739 Ptah, Statuette des Gottes
 60740 Sendet, Statuette der Göttin
 60741 Tata, Statuette des Gottes
 60742 Tatenen, Statuette des Gottes
 60743 Thot, Statuette des Gottes
 60744 Horus, Statuette des Gottes
 60745 Hor-chenti-chem, Statuette des Gottes
 60746 Haroeris, Statuette des Gottes
 60747 Sopdu, Statuette des Gottes
 60747–8 Falken auf Standarten
 60748 Gemehsu, Statuette des
 60748 Gans, Statuette einer
 60750–1 Schlangen auf Standarten
 60751, 60753 Schrein für Schlange auf Standarte
 60754 Netjeranch, Statuette der Schlange
 60756–7 Wachsvogel
 60758–819 Uschebtis, Holz vergoldet
 60820–38 Uschebtis, groß, vergoldet
 60841–6 Uschebtis, Holz bemalt und vergoldet
 60847–95 Uschebtis, Holz bemalt
 60946–7 Uschebtis, Holz
 60948–89 Uschebtis, Alabaster
 60990–1038 Uschebtis, Quarzit
 61039–42 Uschebtis, grauer Granit
 61043–50 Uschebtis, Kalkstein
 61051–2 Uschebtis, Fayence (blau)
 61153–68 Uschebtis, Fayence (beige)
 61163–229 Hacke, Modell (Fayence)
 61169–82 Hacke, Modell (Holz)
 61169–327 Werkzeug, Modell und andere
 61197–8 Vasen, Elfenbein
 61230–40 Hacke, Modell (Kupfer)
 61241–51 Körbe, Modell (Fayence)
 61252–7 Körbe, Modell (Kupfer)
 61258–63 Joche, Modell (Kupfer)
 61264–5 Sichel
 61266–9 Werkzeuge (?)  -form
 61270–88 Messer
 61291 Spachtel
 61292–4 Axt (Dächsel)
 61295–310 Eisen-Werkzeug
 61311–4 Wetzstein
 61315–20 Ellen
 61321 Schlegel, Modell
 61322 Feuerbohrer
 61323–5 Siebe
 61326 Getreidemühle
 61327 Getreidespeicher, Modell
 61328–73 Boote
 61363–73 Ruder
 61374–5 Anubis-Symbole
 61376–9 Magische Figuren von den Grabwänden
 61380–95 Körbe
 61396–443 Vorrats-Behälter
 61444–5 Kästen, tragbar
 61445 Kästen, mit Satteldach
 61446–61 Kästen, rechteckig
 61462–71 Kästen, mit rundem Deckel
 61472–5 Kästen, mit Satteldach
 61476–80 Kästen, mit Naosdach
 61481 Schrein, Gold-Schrein für Statuette
 61482 Schrein für Elle
 61484–8 Kästen, schwarz, für Uschebtis
 61489 Schreine, zwei auf einer Standfläche
 61490–3 Kästen, kartuschenförmig
 61494 Kasten, mit rundem Deckel
 61495 Kasten, halbrund
 61496 Kästen, Teile
 61496 Salbengefäß, (Doppelgefäß)
 61501–2 Bogenkasten
 61503–16 Bogen, lang
 61517–45 Bogen, zusammengesetzt
 61546–7 Bogensehnen
 61548–69 Pfeile
 61570 Köcher
 61571 Handgelenkschutz
 61572–5 Schleudern
 61576–83 Schilde
 61584–7 Dolche
 61588–91 Krummschwerter (Chepesch)
 61592–622 Bumerangs
 61615–22 Wurfhölzer
 61623–4 Keule, Zeremonial-
 61625–37 Knüppel, lang, gerade
 61625–58 Stöcke, Knüppel, Szepter und Stäbe
 61638–51 Knüppel, kurz, gebogen
 61652–3 Stöcke 
 61654–64 Kampfstöcke
 61658–60 Körbe für Kampfstöcke
 61658–60 Handgelenkschutz
 61665–6 Stäbe mit Statuetten des Königs
 61668–71 Stäbe 
 61672–708 Stäbe, Rinden-Dekoration
 61709–15 Stäbe, gerade, vergoldete Enden
 61716–20 Stäbe, gerade,

- vergoldet
 61720–2 Stäbe, gerade
 61723, 61725 Stäbe,
 Rinden-Dekoration
 61726 Stäbe, Gold auf
 Metall-Kern
 61727 Stäbe, knotig
 61728 Rohr, lang, goldverziert
 61729 Rohr, Imitation aus Gold
 61731 Krümmstäbe
 61732–40 Stöcke ←
 61741–56 Stäbe, gebogen
 61757–8 Palmwedel
 61759 Cherep-Szepter
 61760–1 'Geißel des Osiris'
 61762–4 'Krummstab des Osiris'
 61765 Stöcke ←
 61765–73 Knüppel, Stöcke,
 Stäbe, Szepter
 61766–7 Was-Szepter
 61768–71 Stöcke ←
 61772–3 Stöcke ←
 61774–7 Res-Zeichen
 61774–874 Amulette
 61778–85 Djed-Amulett
 61786–9 Was-Amulett
 61790–2 Anch-Zeichen
 61793–827 Wehem-Amulett
 61828–34 Isis-Knoten-Amulett
 61835–47 Amulett, Goldblech
 61848–56 Amulett, Schlangen
 61852 Amulett, Goldblech
 61854–6 Amulett, Goldblech
 61857–61 Amulett,
 Papyrus-Säulen
 61862 Amulett, Muschel
 61863 Amulett, Thot
 61864 Amulett, Horus
 61865 Amulett, Herz- mit
 Benu-Vogel
 61869 Amulett, Kopfstütze
 61872 Skarabäus
 61875–60 Halskragen, Pektoral,
 Anhänger
 61929–38 Perlen, Schnüre mit
 61939–40, 61961 Halsschmuck
 61962–7 Ringe
 61968–73 Ohrschmuck
 61974–7 Skarabäen
 61977 Benu-Vogel auf Skarabäus
 61981 Kette
 61982–7 Spangen aus
 durchbrochenem Goldblech
 61989–94 Wagen
 61995–7 Peitschen
 61998 (?) Wagen
 61999–2006 Fächer
 62000–1 Flagella
 62007–8 Trompeten
 62009–10 Sistra
 62012–9 Betten
 62020–7 Kopfstützen
 62028–34 Sessel
 62035–44 Stühle
 62045–55 Fußbänkchen
 62056 Kissen
 62057–71 Spiele
 62064 Kastagnetten
 62072 Vogel auf Eiern
 62073–8 Schreibrrett
 62079–93 Schreibunterlage
 62094 Schreibrohrbehälter
 62095 Papyrusglätter
 62096 Schreibbinse, Imitation
 62097–103 Farben
 62104–10 Inventar-Schilder
 62111 Lampe
 62111–87 Vasen, Alabaster
 62166, 62188 Vasen, Stein außer
 Alabaster
 62189 Vasen, Alabaster
 62190 Vasen, Gold
 62191–2 Vasen, Silber
 62193 Vase, Deckel aus Kupfer
 (62193) Vasen, Hes-Form
 62195–6 Vasen, Holz
 62199–201 Vasen, Glas
 62202–36 Vasen, Libations-
 62202–69 Vasen, Fayence
 62237–46 Vasen, Hes-Form
 62270–329 Vasen, Keramik
 62300–29 Weinkrüge
 62331–45 Siegel von Vasen
 62346–9 Spiegel
 62350 Kohl-Behälter
 62352 Toiletten-Gefäß in Form
 einer Gans
 62353–7 Fackelhalter
 62357 Ziegel zum Halten einer Fackel
 62359 Vase zwischen zwei
 Pylontürmen
 62360–74 Armbänder, Fayence
 62375–8 Ringe
 62378 (?) Ohrschmuck
 62380–96 Armbänder, Fayence
 62397–404 Armbänder, Stein
 62405–14 Armbänder, Elfenbein
 62421–4 Armbänder, Holz
 62425 Armbänder, Horn
 62426–7 Armbänder, Leder
 62428–34 Ringe, Finger-, Gold
 usw.
 62435 Ringe, Finger-, Harz
 62436–41 Ringe, Finger-, Gold
 usw.
 62452–78 Ringe, Finger-, Fayence
 62581–7 Inventar-Schilder
 62588–624 Schlamm-Siegel von
 Kästen usw.
 62625–6 Gewand, groß
 ('Dalmatika')
 62627 Mieder
 62628 Panzer
 62629 Leopardenkopf von
 Kleidungsstück
 62630 Leopardenfell, Imitation
 62631 Leopardenkopf von
 Kleidungsstück
 62632 Textilien
 62633 Tierschwanz
 62634, 62636–8 Perlenstickerei
 62639–47 Textilien
 62640, 62649–52
 Metallplättchen
 62643–4 Kragen von Kleidung
 62648–9 Rosetten von
 Gewändern
 62654 Textilien
 62654–5 Metallplättchen
 62655–6 Schals, große
 62656–79 Textilien
 62657–64 Schals und Halstücher
 62665 Kopftuch
 62667–8 Lendentücher
 62669–77 Handschuhe
 62678 Fingerschutz aus Stoff
 62679 Textilien
 62680–92 Sandale
 62693 Textilien
 62694–7 Leichentücher
 62698 Kissen (vom Kopf des
 Königs)
 62700 Kopfring aus Textilien
 62702 Leichentücher
 62703 Inschriften auf Stoffstücken
 62707–8 Beutel
 62710–1 Brote
 62710–23 Speise usw.
 62712–3 Gerste
 62712–4 Getreide
 62712–38 Gemüse
 62715 Datteln
 62717–8 Wacholderbeeren
 62717–21 Saatgut
 62720 Melonen-Kerne
 62721 *Nabq* Frucht
 62722 Zwiebel
 62723 Persea-Früchte
 62724–30 Sträuße
 62724–31 Persea-Blätter
 62732 Binsen, Bündel von
 62733–6 Kränze
 62737–8 Papyrusmark
 62741 Weihrauch
 62743 Blei, Probe von
 62744 Zinn, Probe von
 62745 Rosetten vom Bahrtuch
 62746 Decke vom Wagen
 62747–50 Fliegenwedel
 62751–2 Perlenstickerei
 62753 Bleiglanz
 62757–61 Armbänder, Leder
 87847–9 Spangen aus
 durchbrochenem Goldblech
 87850 Sarg, innerer (Goldsarg)
 87851 Schreine, die vier großen
 87852–4 Uschebtis, Fayence (blau)
 87855 Vasen, Libations-
 87856 Vasen, Fayence
 87857 Anch-Zeichen

INDEX TO THE JOURNAL D'ENTRÉE

(objects listed in alphabetical order)

- adze 61292-4
amphorae; see vases, wine
Amset, statuette of god 60727
amulet, headrest 61869
amulet, heart and benu-bird 61865
amulet, Horus 61864
amulet, papyrus columns 61857-1
amulet, serpents 61848-56
amulet, sheet gold 61835-47, 61852, 61854-6
amulet, shell 61862
amulet, Thoth 61863
amulets 61774-874
Ankh emblems 61790-2, 87857
Anubis emblems 61374-5
apron 60685
arrows 61548-69
Atum, statuette of god 60734
- bags 62707-8
barley 62712-3
baskets 61380-95
baskets, model copper 61252-7
baskets, model faience 61241-51
beads, strings of 61929-38
beadwork 62634
beadwork 62636-8
beadwork 62751-2
bed of Osiris 60703
beds 62012-9
belts, from mummy 60676-7
benu-bird on heart amulet 61865
benu-bird on scarab 61977
bier 60669
bird of wax 60756-7
bird on eggs 62072
boats 61328-73
boomerangs 61592-622
bouquets 62724-30
bow cases 61501-2
bows, composite 61517-45
bows, long 61503-16
bowstrings 61546-7
boxes, black, for shawabtis 61484-88
boxes, cartouche-shaped 61490-3
boxes, curved sided 61495
boxes for bows 61501-2
boxes for food offerings 61396-443
boxes, gable-lidded 61445, 61472-5
boxes, lids like shrine roofs 61476-80
boxes, parts of 61496
boxes, rectangular 61446-61
boxes, rounded lids 61462-71, 61494
bracelets, faience 62360-74, 62380-96
bracelets, horn 62425
bracelets, ivory 62405-14
bracelets, leather 62426-7, 62757-61
bracelets, stone 62397-404
bracelets, wood 62421-4
brick to hold torch 62357
- Canopic chests, etc. 60686-91
carrying chests 61444-5
cartouche-shaped box 61490-3
castanets 62064
cereals 62712-4
chain 61981
chairs 62028-34
chariots 61989-94, 61998 (?)
chariots, rug from 62746
clubs, sticks, wands, sceptres 61625-58, 61765-73
clubs, long, straight 61625-37
clubs, short, curved 61638-51
coffin, innermost gold 60671, 87850
coffin for hair of Tiye 60697-701
coffins for foetuses 60692-6
coffins, miniature canopic 60688-91
coffin, second innermost 60670
collars of garments 62643-4
collars, pectorals and pendants 61875-960
corn mill 61326
corselet 62627
Cow, head of Hathor 60736
crook sticks 61731
'Crook of Osiris' 61762-4
cubit rods 61315-20
cuirass 62628
cups, see Vases
- Djed amulets 61778-85
daggers 61584-7
dates (fruit) 62715
diadem from mummy 60684
divinities, statuettes of 60724-57
Duamutef, statuette of god 60728-9
- ear ornaments 61968-73, 62378 (?)
emblems of Anubis 61374-5
- falcons on stands 60747-8
fans 61999-0206
finger-stalls, gold 60680-1
fire-drill 61322
Flagella 62000-1
'Flail of Osiris' 61760-1
fly-whisks 62747-50
foetus, coffins for 60692-6
food etc. 62710-23
food-boxes 61396-443
- footstools 62045-55
- galena 62753
games 62057-71
garments, large dalmatic 62625-6
gauntlets, see gloves
Geb, statuette of god 62735
gloves 62669-77
Gem-hesu, statuette of 60748
Goose of Amun, statuette of 60748
granary, model 61327
grinder 61326
guards for single sticks 61658-60
- hair of Queen Tyi 60701
hampers 61380-95
Hapi, statuette of god 60726
harness, see Chariots
Haroeris, statuette of god 60746
hassocks 62056, 62751-2
Hathor, head of cow 60736
head-bands from mummy 60674-5
head cloths 62665
headrest amulet 61869
headrest 62020-7
head-ring 62700
heart and benu amulet 61865
hoes, model copper 61230-40
hoes, model faience 61163-229
hoes, model wooden 61169-82
hones 61311-4
Hor-khenti-khem, statuette of god 60745
Horus, statuette of god 60744
Horus amulet 61864
Horus the Great, statuette of god 60746
- Ihi, statuette of god 60731-2
Imseti, statuette of god 60727
incense 62741
infants, coffins of premature 60692-6
inscriptions on bits of cloth 62703
inventory labels 62104-10, 62581-7
iron tools 61295-310
Isis, statuette of goddess 60734
- juniper berries 62717-8
- Kebehsenuf, statuette of god 60730
Kheperi, statuette of god 60737
Khepesh sword 61588-91
Kherp sceptre 61759
king, life sized statues of 60707-8
king (?), bust of 60722
king, head of 60723

- king, statuettes of 60709–20
knives (see also daggers and swords) 61270–88
'Knot of Isis' amulets 61828–34
kohl containers 62350
- lamp 62111
lead, sample of 62743
lead, sample of 62753
leopard's head, from garment 62629
leopard's head, from garment 62631
leopard's skin 62630
loaves 62710–1
loin cloths 62667–8
- mace, ceremonial 61623–4
magical figures from tomb walls 61376–9
mallet, model 61321
Mamu, statuette of god 60738
marquee 60704–6
mask, gold 60672
melon seeds 62720
mirrors 62346–9
mud sealings of boxes etc. 62588–624
- nabq* fruit 62721
naos (see also shrines) 61481
Nephthys, statuette of goddess 60725
Neterankh, statuette of serpent 60754
- onions 62722
Onuris–Shu, statuette of god 60733
Osiris, 'bed of' 60703
Osiris, 'crook of' 61762–4
Osiris 'flail of' 61760–1
Osiris, king on bier as 60720–1
- pad (from head of king) 62698
paddles 61363–73
pall, samples from 62745
pall, support of 60665
palm fronds 61757–8
papyrus column amulets 61857–61
papyrus pith 62737–8
papyrus polisher 62095
pavilion 60704–6
pen-case 62094
persea fruit 62723
persea leaves 62724–31 (see also wreaths and bouquets)
pigments 62097–103
plaques of stained gold 61982–7, 87847–9
polisher, for papyrus 62095
pottery, see vases
premature infants' coffins 60692–6
Ptah, statuette of god 60739
- queen (?), bust of 60722
quiver 61570
- reed, long gold mounted 61728
reed, long imitation 61729
reed, imitation writing- 62096
res-signs 61774–7
- rings, finger, faience 62452–78
rings, finger, gold etc. 62428–34, 62436–41
rings, finger, resin 62435
rings, head- 62700
rings 61962–7, 62375–8
rosettes from pall 62745
rosettes from robes 62648–9
rug from chariot 62746
rushes, bundle of 62732
- sandals, gold from mummy 60678–9
sandals 62680–92
saucers, see vases
scarabs, plain (see also rings) 61872, 61974–7
scarves, see shawls
scimitars 61588–91
sealings, mud, from boxes etc. 62588–624
sealings of vases 62331–45
seeds 62712–4
seeds 62717–21
Sendet, statuette of goddess 60740
sequins 62640, 62649–52, 62654–5
serpents on stand with shrines 60750–1
serpent, the god Neterankh 60754
set buckle 61828–34
shawabti, boxes for 61484–8
shawabti, alabaster 60948–89
shawabti, faience (cream) 61153–68
shawabti, faience (blue) 61051–2
shawabti, faience (blue) 87852–4
shawabti, grey granite 61039–42
shawabti, large gilt 60820–38
shawabti, limestone 61043–50
shawabti, quartzite 60990–1038
shawabti, wood gilt 60758–819
shawabti, wood painted 60847–95
shawabti, wood painted and gilt 60841–6
shawabti, wood plain 60946–7
shawl, large 62655–6
shawls and scarves 62657–64
shell amulet 61862
shields 61576–83
shrine, the outermost 60664
shrines, the 2nd, 3rd and innermost 60666–8
shrines, the four great 87851
shrine, tall thin, for cubit rod 61482
shrine, gold plated, for a statuette 61481
shrines for serpents on stand 60751, 60753
shrine-shaped boxes for shawabti 61484–8
shrines, two on stand 61489
shrouds 62694–7, 62702
sickles 61264–5
single sticks 61654–64
sistra 62009–10
slings 61572–5
Sopd, statuette of falcon-god 60747
spatula 61291
- 'sporrán' 60685
statues of King (life size) 60707–8
statuettes of divinities 60724–57
statuettes of King 60709–20
sticks, clubs, sceptres and wands 61625–58, 61765, 61773
sticks, bark decoration 61672–708, 61723, 61725
sticks curved 61741–56
sticks gold on metal core 61726
sticks knobby, with gilt ends 61727
sticks with statuette of king on top 61665–6
sticks straight, gilt ends 61709–15
sticks straight gilt 61716–20
sticks straight plain 61720–2
sticks throwing 61615–22
sticks 60730–1
sticks — 61652–3
sticks —c 61668–71
sticks —> 61768–71
sticks — 61732–40, 61765
sticks —> 61772–3
stools 62035–44
strainers 61323–5
support for pall 60665
swords (Khepesh) 61588–91
- Tata, statuette of god 60741
tail, ceremonial 62633
Thoth, statuette of god 60743
Thoth, amulet 61863
Tatenen, statuette of god 60742
textiles 62625–6, 62632, 62639–47, 62654, 62656–79, 62693
thrones, see chairs
throw-sticks (see also boomerangs) 61615–22
thumb (?)—stall 62678
tin, sample of 62744
Tiye, lock of hair of 60701
toe-stalls, gold 60682–3
toilet box in form of goose 62352
toilet (perfume) box, double 61496
torch holders 62353–7
tools, model and other 61169–327
tools (?) —form 61266–9
torques (for neck) 61939–40, 61961
toys (see games)
trappings of royal mummy 60673, 60685
trumpets 62007–8
- uhem* amulets 61793–827
- vases, alabaster 62111–87, 62189
vase between towers 62359
vase cover of copper 62193
vases, faience 62202–69, 87856
vases, glass 62199–201
vases, gold 62190
vases, *hes*-form (62193), 62237–46
vases, model ivory 61197–8
vases, libation ('tea-pots') 62202–36, 87855
vases, pottery 62270–329
vases, sealings of 62331–45

vases, silver 62191–2
vases, stone other than alabaster
62166, 62188
vases, wine jars 62300–29
vases, wood 62195–6
vegetable growths 62712–38

wands, see sticks
was amulet 61786–9
was sceptres 61766–7
wax birds 60756–7
whips 61995–7
wine jars 62300–29

wreaths 62733–6
wrist protectors 61571, 61658–60
writers' palettes 62079–93
writing-boards 62073–8
yokes, model copper 61258–63

INDEX TO THE JOURNAL D'ENTRÉE

(listed by JE numbers)

- 60664 Shrine, first outermost
60665 Pall, support of
60665 Support for pall
60666–8 Shrines, 2nd, 3rd, and innermost
60669 Bier
60670 Coffin, second innermost
60671 Coffin, innermost gold
60672 Mask, gold
60673 Trappings of royal mummy
60674–5 Head-bands from mummy
60676–7 Belts, from mummy
60678–9 Sandals, gold from mummy
60680–1 Finger-stalls, gold
60682–3 Toe-stalls, gold
60684 Diadem from mummy
60685 'Sporran'
60685 Apron
60685 Trappings of royal mummy
60686–91 Canopic chests, etc
60688–91 Coffins, miniature canopic
60692–6 Coffins for fetuses
60697–701 Coffin for hair of Tiye
60701 Hair of Queen Tiye
60703 Bed of Osiris
60704–6 Pavilion
60707–8 King, life sized statues of
60709–20 Statuettes of King
60720–1 Osiris, king on bier as
60722 King (?), bust of
60722 Queen (?), bust of
60723 King, head of
60724–57 Statuettes of divinities
60725 Nephthys, statuette of goddess
60726 Hapi, statuette of god
60727 Amset, statuette of god
60728–9 Duamutef, statuette of god
60730 Kebehsenuf, statuette of god
60731–2 Ihi, statuette of god
60733 Onuris-Schu, statuette of god
60734 Atum, statuette of god
60734 Isis, statuette of goddess
60736 Cow, head of Hathor
60737 Kheperi, statuette of god
60738 Mamu, statuette of god
60739 Ptah, statuette of god
60740 Sendet, statuette of goddess
60741 Tata, statuette of god
60742 Tatenen, statuette of god
60743 Thoth, statuette of god
60744 Horus, statuette of god
60745 Hor-khenti-khem, statuette of god
60746 Haroeris, statuette of god
60747 Soped, statuette of falcon-god
60747–8 Falcons on stands
60748 Gem-hesu, statuette of
60748 Goose of Amun, statuette of
60750–1 Serpents on stand with shrines
60751 Shrines for serpents on stand
60753 Shrines for serpents on stand
60754 Neterankh, statuette of serpent
60756–7 Wax birds
60758–819 Shawabtis, wood gilt
60820–38 Shawabtis, large gilt
60841–6 Shawabtis, wood painted and gilt
60847–95 Shawabtis, wood painted
60946–7 Shawabtis, wood plain
60948–89 Shawabtis, alabaster
60990–1038 Shawabtis, quartzite
61039–42 Shawabtis, grey granite
61043–50 Shawabtis, limestone
61051–2 Shawabtis, faience (blue)
61153–68 Shawabtis, faience (cream)
61163–229 Hoes, model faience
61169–82 Hoes, model wooden
61169–327 Tools, model and other
61197–8 Vases, model ivory
61230–40 Hoes, model copper
61241–51 Baskets, model faience
61252–7 Baskets, model copper
61258–63 Yokes, model copper
61264–5 Sickles
61266–9 Tools (?)  -form
61270–88 Knives
61291 Spatula
61292–4 Adze
61295–310 Iron tools
61311–4 Hones
61315–20 Cubit rods
61321 Mallet, model
61322 Fire-drill
61323–5 Strainers
61326 Corn mill
61327 Granary, model
61328–73 Boats
61363–73 Paddles
61374–5 Anubis emblems
61376–9 Magical figures from tomb walls
61380–95 Baskets
61396–2443 Food-boxes
61444–5 Carrying chests
61445 Boxes, gable-lidded
61446–61 Boxes, rectangular
61462–71 Boxes, rounded lids
61472–5 Boxes, gable-lidded
61476–80 Boxes, lids like shrine roofs
61481 Shrine, gold plated, for a statuette
61482 Shrine, tall thin, for cubit rod
61484–8 Boxes, black, for shawabtis
61489 Shrines, two on stand
61490–3 Boxes, cartouche-shaped
61494 Boxes, rounded lids
61495 Boxes, curved sided
61496 Boxes, parts of
61496 Toilet (perfume) box, double
61501–2 Bow cases
61503–16 Bows, long
61517–45 Bows, composite
61546–7 Bowstrings
61548–69 Arrows
61570 Quiver
61571 Wrist protectors
61572–5 Slings
61576–83 Shields
61584–7 Daggers
61588–91 Swords (Khepesh)
61592–622 Boomerangs
61615–22 Throw-sticks
61623–4 Mace, ceremonial
61625–37 Clubs, long, straight
61625–758 Sticks, clubs, sceptres and wands
61638–51 Clubs, short, curved
61652–3 Sticks 
61654–64 Single sticks
61658–60 Guards for single sticks
61658–60 Wrist protectors
61665–6 Sticks with statuette of king on top
61668–71 Sticks 
61672–708 Sticks, bark decoration
61709–15 Sticks straight, gilt ends
61716–20 Sticks straight gilt
61720–2 Sticks straight plain
61723 Sticks, bark decoration
61725 Sticks, bark decoration
61726 Sticks gold on metal core
61727 Sticks knobably, with gilt ends
61728 Reed, long gold mounted
61729 Reed, long imitation
61731 Crook sticks
61732–40 Sticks 
61741–56 Sticks curved
61757–8 Palm fronds
61759 Kherp sceptre
61760–61 'Flail of Osiris'
61762–64 'Crook of Osiris'
61765 Sticks, clubs, sceptres and wands
61765 Sticks 
61765–73 Clubs, sticks, wands, sceptres
61766–7 Was sceptres
61768–71 Sticks 
61772–3 Sticks 
61773 Sticks, clubs, sceptres and wands
61774–7 Res-signs

- 61774–874 Amulets
 61778–85 Djed amulets
 61786–9 Was amulet
 61790–2 Ankh emblems
 61793–827 Uhem amulets
 61828–34 'Knot of Isis' amulets
 61835–47 Amulet, sheet gold
 61848–56 Amulet, serpents
 61852 Amulet, sheet gold
 61854–6 Amulet, sheet gold
 61857–61 Amulet, papyrus columns
 61862 Amulet, shell
 61863 Amulet, Thot
 61864 Amulet, Horus
 61865 Amulet, heart and benu-bird
 61869 Amulet, headrest
 61872 Scarabs, plain
 61875–960 Collars, pectorals and pendants
 61929–38 Beads, strings of
 61939–40 Torques (for neck)
 61961 Torques (for neck)
 61962–7 Rings
 61968–73 Ear ornaments
 61974–7 Scarabs, plain
 61977 Benu-bird on scarab
 61981 Chain
 61982–7 Plaques of stained gold
 61989–94 Chariots
 61995–7 Whips
 61998 (?) Chariots
 61999–2006 Fans
 62000–1 Flagella
 62007–8 Trumpets
 62009–10 Sistra
 62012–9 Beds
 62020–7 Headrest
 62028–34 Chairs
 62035–44 Stools
 62045–55 Footstools
 62056 Hassocks
 62057–71 Games
 62064 Castanets
 62072 Bird on eggs
 62073–8 Writing-boards
 62079–93 Writers' palettes
 62094 Pen-case
 62095 Papyrus polisher
 62096 Reed, imitation writing-
 62097–103 Pigments
 62104–10 Inventory labels
 62111 Lamp
 62111–87 Vases, alabaster
 62166 Vases, stone other than alabaster
 62188 Vases, stone other than alabaster
 62189 Vases, alabaster
 62190 Vases, gold
 62191–2 Vases, silver
 62193 Vase cover of copper
 (62193) Vases, hes-form
 62195–6 Vases, wood
 62199–201 Vases, glass
 62202–36 Vases, libation (tea-pots)
 62202–69 Vases, faience
 62237–46 Vases, hes-form
 62270–329 Vases, pottery
 62300–29 Wine jars
 62331–45 Sealings of vases
 62346–9 Mirrors
 62350 Kohl containers
 62352 Toilet box in form of goose
 62353–7 Torch holders
 62357 Brick to hold torch
 62359 Vase between towers
 62360–74 Bracelets, faience
 62375–8 Rings
 62378 (?) Ear ornaments
 62380–96 Bracelets, faience
 62397–404 Bracelets, stone
 62405–14 Bracelets, ivory
 62421–4 Bracelets, wood
 62425 Bracelets, horn
 62426–7 Bracelets, leather
 62428–34 Rings, finger, gold etc
 62435 Rings, finger, resin
 62436–41 Rings, finger, gold etc
 62452–78 Rings, finger, faience
 62581–7 Inventory labels
 62588–624 Mud sealings of boxes etc
 62625–6 Garments, large dalmatic
 62627 Corset
 62628 Cuirass
 62629 Leopard's head, from garment
 62630 Leopard's skin
 62631 Leopard's head, from garment
 62632 Textiles
 62633 Tail, ceremonial
 62634 Beadwork
 62636–8 Beadwork
 62639–47 Textiles
 62640 Sequins
 62649–52 Sequins
 62643–4 Collars of garments
 62648–9 Rosettes from robes
 62654 Textiles
 62654–5 Sequins
 62655–6 Shawl, large
 62656–79 Textiles
 62657–64 Shawls and scarves
 62665 Head cloths
 62667–8 Loin cloths
 62669–77 Gloves
 62678 Thumb (?)–stall
 62679 Textiles
 62680–92 Sandals
 62693 Textiles
 62694–7 Shrouds
 62698 Pad (from head of king)
 62700 Head-ring
 62702 Shrouds
 62703 Inscriptions on bits of cloth
 62707–8 Bags
 62710–1 Loaves
 62710–23 Food etc
 62712–3 Barley
 62712–4 Cereals
 62712–38 Vegetable growths
 62715 Dates (fruit)
 62717–8 Juniper berries
 62717–21 Seeds
 62720 Melon seeds
 62721 Nabq fruit
 62722 Onions
 62723 Persea fruit
 62724–30 Bouquets
 62724–31 Persea leaves
 62732 Rushes, bundle of
 62733–6 Wreaths
 62735 Geb, statuette of god
 62737–8 Papyrus pith
 62741 Incense
 62743 Lead, sample of
 62744 Tin, sample of
 62745 Rosettes from pall
 62746 Rug from chariot
 62747–50 Fly-whisks
 62751–2 Beadwork
 62753 Galena
 62757–61 Bracelets, leather
 87847–9 Plaques of stained gold
 87850 Coffin, innermost gold
 87851 Shrines, the four great
 87852–4 Shawabti, faience (blue)
 87855 Vases, libation ('tea-pots')
 87856 Vases, faience
 87857 Ankh emblems

